

FOREWORD

This manual contains an introductory description on HYOSUNG 『MSB 250/250』 and procedures for its inspection/service and overhaul of its main components.

Other information considered as generally known is not included.

Read GENERAL INFORMATION section to familiarize yourself with outline of the vehicle and MAINTENANCE and other sections to use as a guide for proper inspection and service.

This manual will help you know the vehicle better so that you can assure your customers of your optimum and quick service.

❖ This manual has been prepared on the basis of the latest specification at the time of publication.

If modification has been made since then, difference may exist between the content of this manual and the actual vehicle.

❖ Illustrations in this manual are used to show the basic principles of operation and work procedures.

They may not represent the actual vehicle exactly in detail.

WARNING

This manual is intended for those who have enough knowledge and skills for servicing HYOSUNG vehicles. Without such knowledge and skills, you should not attempt servicing by relying on this manual only.

Instead, please contact your nearby authorized HYOSUNG motorcycle dealer.

GROUP INDEX

GENERAL INFORMATION

1

PERIODIC MAINTENANCE

2

ENGINE

3

FI SYSTEM DIAGNOSIS

4

FUEL SYSTEM AND THROTTLE BODY

5

COOLING SYSTEM

6

ELECTRICAL SYSTEM

7

CHASSIS

8

SERVICING INFORMATION

9



HOW TO USE THIS MANUAL

TO LOCATE WHAT YOU ARE LOOKING FOR :

1. The text of this manual is divided into sections.
2. As the title of these sections is listed on the previous page as GROUP INDEX, select the section where you are looking for.
3. Holding the manual as shown at the right will allow you to find the first page of the section easily.
4. On the first page of each section, its contents are listed. Find the item and page you need.

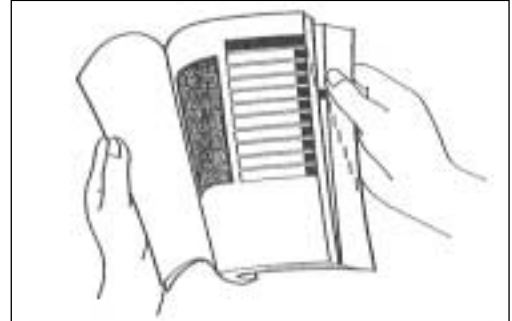





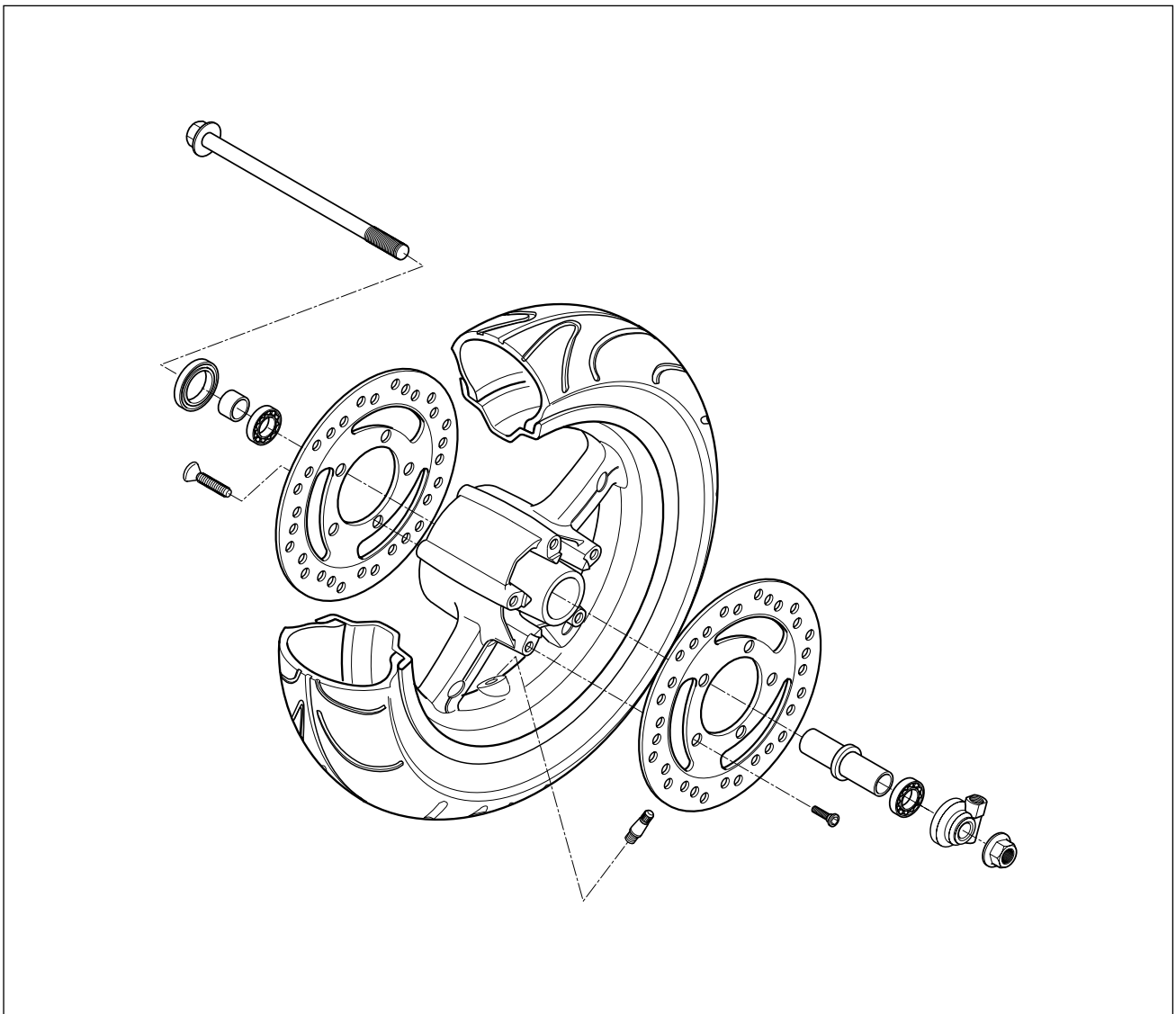











COMPONENT PARTS

Example : Front wheel



SYMBOL

Listed in the table below are the symbols indicating instructions and other information necessary for servicing and meaning associated with them respectively.

SYMBOL	DEFINITION	SYMBOL	DEFINITION
	Torque control required. Data beside it indicates specified torque.		Apply THREAD LOCK "1324".
	Apply oil. Use engine oil unless otherwise specified.		Apply or use brake fluid.
	Apply SUPER GREASE "A".		Measure in voltage range.
	Apply SUPER GREASE "C".		Measure in resistance range.
	Apply SILICONE GREASE.		Measure in current range.
	Apply MOLY PASTE.		Measure in continuity test range.
	Apply BOND "1215".		Use special tool.
	Use fork oil.		Use engine coolant.

ABBREVIATIONS USED IN THIS MANUAL

A

ABDC : After Bottom Dead Center
AC : Alternating Current
API : American Petroleum Institute
ATDC : After Top Dead Center

B

BBDC : Before Bottom Dead Center
BDC : Bottom Dead Center
BTDC : Before Top Dead Center

D

DC : Direct Current
DOHC : Double Over Head Camshaft

E

ECU : Engine Control Unit,
FI Control Unit

F

FI : Fuel Injection, Fuel Injector
FP : Fuel Pump

I

IAP Sensor : Intake Air Pressure Sensor
(IAPS)
IAT Sensor : Intake Air Temperature Sensor
(IATS)
IG : Ignition
ISC Solenoid : Idle Speed Control Solenoid

L

LCD : Liquid Crystal Display
LED : Light Emitting Diode
LH : Left Hand

M

Max : Maximum
Min : Minimum

O

O₂ Sensor : Oxygen Sensor (O₂S)

R

RH : Right Hand

S

SAE : Society of Automotive Engineers
SAV Solenoid : Secondary Air Valve Solenoid

T

TDC : Top Dead Center
TO Sensor : Tip Over Sensor (TOS)
TP Sensor : Throttle Position Sensor (TPS)

W

WT Sensor : Water Temperature Sensor
(WTS)

WIRE COLOR

B	: Black	Gr	: Gray	Sb	: Light blue
L	: Blue	Lg	: Light green	W	: White
Br	: Brown	O	: Orange	Y	: Yellow
G	: Green	R	: Red		

BL	: Black with Blue tracer	BBr	: Black with Brown tracer
BG	: Black with Green tracer	BO	: Black with Orange tracer
BR	: Black with Red tracer	BW	: Black with White tracer
BY	: Black with Yellow tracer	LB	: Blue with Black tracer
LG	: Blue with Green tracer	LR	: Blue with Red tracer
LW	: Blue with White tracer	LY	: Blue with Yellow tracer
BrB	: Brown with Black tracer	BrW	: Brown with White tracer
GB	: Green with Black tracer	GR	: Green with Red tracer
GY	: Green with Yellow tracer	GrB	: Gray with Black tracer
GrR	: Gray with Red tracer	GrW	: Gray with White tracer
OB	: Orange with Black tracer	OL	: Orange with Blue tracer
OG	: Orange with Green tracer	OR	: Orange with Red tracer
OW	: Orange with White tracer	OY	: Orange with Yellow tracer
RB	: Red with Black tracer	RW	: Red with White tracer
WB	: White with Black tracer	WL	: White with Blue tracer
WR	: White with Red tracer	YB	: Yellow with Black tracer
YL	: Yellow with Blue tracer	YG	: Yellow with Green tracer
YR	: Yellow with Red tracer		



NOTE

Difference between photographs and actual motorcycles depends on the markets.

GENERAL INFORMATION

CONTENTS

INFORMATION LABELS	1- 1
GENERAL PRECAUTIONS	1- 2
SERIAL NUMBER LOCATION	1- 3
FUEL, OIL AND ENGINE COOLANT RECOMMENDATIONS	1- 4
BREAK-IN PROCEDURES	1- 6
EXTERIOR ILLUSTRATION	1- 7
SPECIFICATIONS	1- 8

WARNING / CAUTION / NOTE

Please read this manual and follow its instructions carefully.

To emphasize special information, the symbol and the words WARNING, CAUTION and NOTE have special meanings. Pay special attention to the messages highlighted by these signal words.

 WARNING
Indicates a potential hazard that could result in death or injury.

 CAUTION
Indicates a potential hazard that could result in vehicle damage.

NOTE
<i>Indicates special information to make maintenance easier or instructions clearer.</i>

Please note, however, that the warning and cautions contained in this manual cannot possibly cover all potential hazards relating to the servicing, or lack of servicing, of the motorcycle. In addition to the WARNING and CAUTION stated, you must use good judgement and basic mechanical safety principles. If you are unsure about how to perform a particular service operation, ask a more experienced mechanic for advice.

GENERAL PRECAUTIONS

WARNING

- ❖ Proper service and repair procedures are important for the safety of the service machanic and the safety and reliability of the vehicle.
- ❖ When 2 or more persons work together, pay attention to the safety of each other.
- ❖ When it is necessary to run the engine indoors, make sure that exhaust gas is forced outdoors.
- ❖ When working with toxic or flammable materials, make sure that the area you work in is well-ventilated and that you follow all off the material manufacturer's instructions.
- ❖ Never use gasoline as a cleaning solvent.
- ❖ To avoid getting burned, do not touch the engine, engine oil, exhaust system or radiator during or for a while after engine operation.
- ❖ After servicing fuel, oil, engine coolant, exhaust or brake systems, check all lines and fittings related to the system for leaks.

WARNING

- ❖ If parts replacement is necessary, replace the parts with HYOSUNG Genuine Parts or their equivalent.
- ❖ When removing parts that are to be reused, keep them arranged in an orderly manner so that they may be reinstalled in the proper order and orientation.
- ❖ Be sure to use special tools when instructed.
- ❖ Make sure that all parts used in reassembly are clean, and also lubricated when specified.
- ❖ When use of a certain type of lubricant, bond, or sealant is specified, be sure to use the specified type.
- ❖ When removing the battery, disconnect the \ominus battery lead wire first and then the \oplus battery lead wire. When reconnecting the battery, connect the \oplus battery lead wire first and then the \ominus battery lead wire. Finally, cover the \oplus battery terminal with the terminal cover.
- ❖ When performing service to electrical parts, if the service procedures do not require use of battery power, diconnect the \ominus battery lead wire at the battery.
- ❖ Tighten cylinder head and case bolts and nuts, beginning with larger diameter and ending with smaller diameter, from inside to outside diagonally, to the specified tightening torque.
- ❖ Whenever you remove oil seals, gaskets, packing, O-rings, locking washers, cotter pins, circlips, and certain other parts as specified, be sure to replace them with new ones. Also, before installing these new parts, be sure to remove any material left over from the mating surfaces.
- ❖ Never reuse a circlip. When installing a new circlip, take care not to expand the end gap larger than required to slip the circlip over the shaft. After installing a circlip, always ensure that it is completely seated in its groove and securely fitted.
- ❖ Do not use self-locking nuts a few times over.
- ❖ Use a torque wrench to tighten fasteners to the torque values when specified. Wipe off grease or oil if a thread is smeared with them.
- ❖ After reassembly, check parts for tightness and operation.

WARNING

- ❖ To protect environment, do not unlawfully dispose of used motor oil and other fluids: batteries, and tires.
- ❖ To protect Earth's natural resouces, properly dispose of used vehicles and parts.

SERIAL NUMBER LOCATION

The frame serial number or V.I.N. (Vehicle Identification Number) is stamped on the right downside frame.
The engine serial number is stamped on the left rearside of the crankcase assembly.
These numbers are required especially for registering the machine and ordering spare parts.

◎ FRAME SERIAL NUMBER

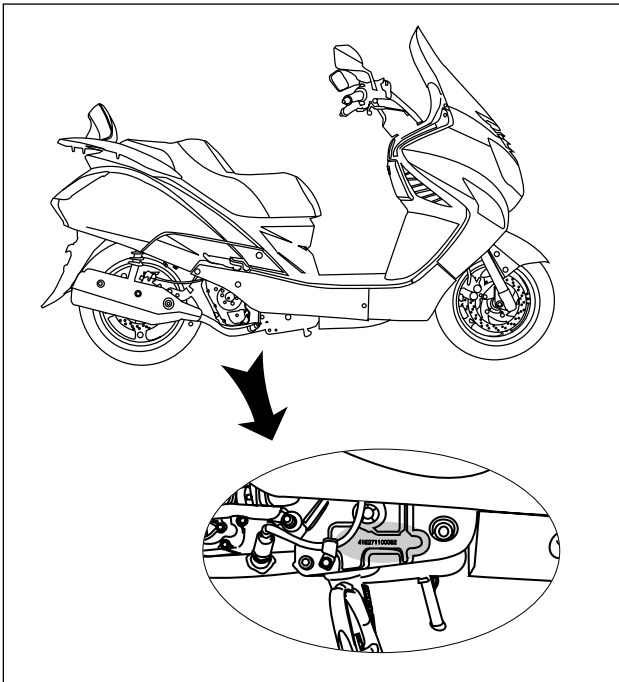

◎ ENGINE SERIAL NUMBER

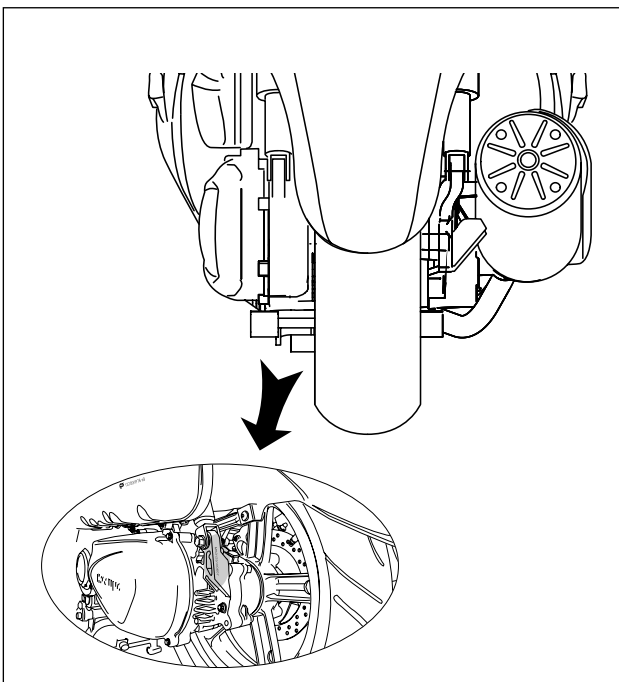

FUEL, OIL AND ENGINE COOLANT RECOMMENDATIONS

⦿ FUEL

Gasoline used should be graded 91 octane (Research Method) or higher. An unleaded gasoline type is recommended.

⦿ ENGINE OIL

▣ ENGINE OIL SPECIFICATION

Classification system	Grade
API	Over SL
SAE	10W/40

※ If an SAE 10W/40 motor oil is not available, select an alternative according to the following chart.

Temperature	°C		°F								
	-30	-20	-10	0	10	20	30	40			
ENGINE OIL	20W50		15W40 15W50		10W40 10W50		10W30		5W30		
	-30		-20		-10		0		10		
		-22		-4		14		32		50	
										68	
										86	
										104	

Use a premium quality 4-stroke motor oil to ensure longer service life of your vehicle.

⚠ WARNING

- ❖ Don't mix the unrecommended oil. It could damage the engine.
- ❖ When refilling the oil, don't allow the dust to get inside.
- ❖ Wipe the spilled oil up immediately.
- ❖ Don't put the patch on the filler cap. It could disturb the oil to be provided and damage the engine.

⦿ TRANSMISSION OIL

Make sure that the transmission oil you use comes under API classification of more than SL and that its viscosity rating is SAE 10W/40.

⚠ WARNING

- ❖ Don't mix the unrecommended oil. It could damage the transmission.
- ❖ When refilling the oil, don't allow the dust to get inside.
- ❖ Wipe the spilled oil up immediately.
- ❖ Don't put the patch on the filler cap. It could disturb the oil to be provided and damage the transmission.

⦿ BRAKE FLUID

- ▣ Specification and classification (Front brake) : DOT4
(Rear brake) : DOT4

⚠ WARNING

Since the brake system of this vehicle is filled with a glycol-based brake fluid by the manufacturer, do not use or mix different types of fluid such as silicone-based and petroleum-based fluid for refilling the system, otherwise serious damage will result.

Do not use any brake fluid taken from old or used or unsealed containers.

Never re-use brake fluid left over from a previous servicing, which has been stored for a long period.

⊙ FRONT FORK OIL

- ▣ Use fork oil : TELLUS #22

⊙ ENGINE COOLANT

Use an anti-freeze / engine coolant compatible with an aluminum radiator, mixed with distilled water only.

▣ WATER FOR MIXING

Use distilled water only. Water other than distilled water can corrode and clog the aluminum radiator.

▣ ANTI-FREEZE / ENGINE COOLANT

The engine coolant perform as a corrosion and rust inhibitor as well as anti-freeze. Therefore, the engine coolant should be used at all times even though the atmospheric temperature in your area does not go down to freezing point.

Hyosung recommends the use of HYOSUNG COOLANT anti-freeze / engine coolant. If this is not available, use an equivalent which is compatible with an aluminum radiator.

▣ LIQUID AMOUNT OF WATER / ENGINE COOLANT

For engine coolant mixture information, refer to cooling system section, page 6-1.

 CAUTION
--

<p>Mixture of anti-freeze / engine coolant should be limited to 60%. Mixing beyond it would reduce its efficiency. If the anti-freeze / engine coolant mixing ratio is below 50%, rust inhabiting performance is greatly reduced. Be sure to mix it above 50% even though the atmospheric temperature does not go down to the freezing point.</p>
--

BREAK-IN PROCEDURES

During manufacture only the best possible materials are used and all machined parts are finished to a very high standard but it is still necessary to allow the moving parts to "BREAK-IN" before subjecting the engine to maximum stresses.

The future performance and reliability of the engine depends on the care and restraint exercised during its early life. The general rules are as follows :

- Keep to these break-in procedures :

Interval	Maximum throttle opening
Initial 800 Km (500 miles)	Less than 1/2 throttle
Up to 1,600 Km (1,000 miles)	Less than 3/4 throttle

- Upon reaching an odometer reading of 1,600 km (1,000 miles) you can subject the motorcycle to full throttle operation.
- Do not maintain constant engine speed for an extended period during any portion of the break-in. Try to vary the throttle position.

EXTERIOR ILLUSTRATION

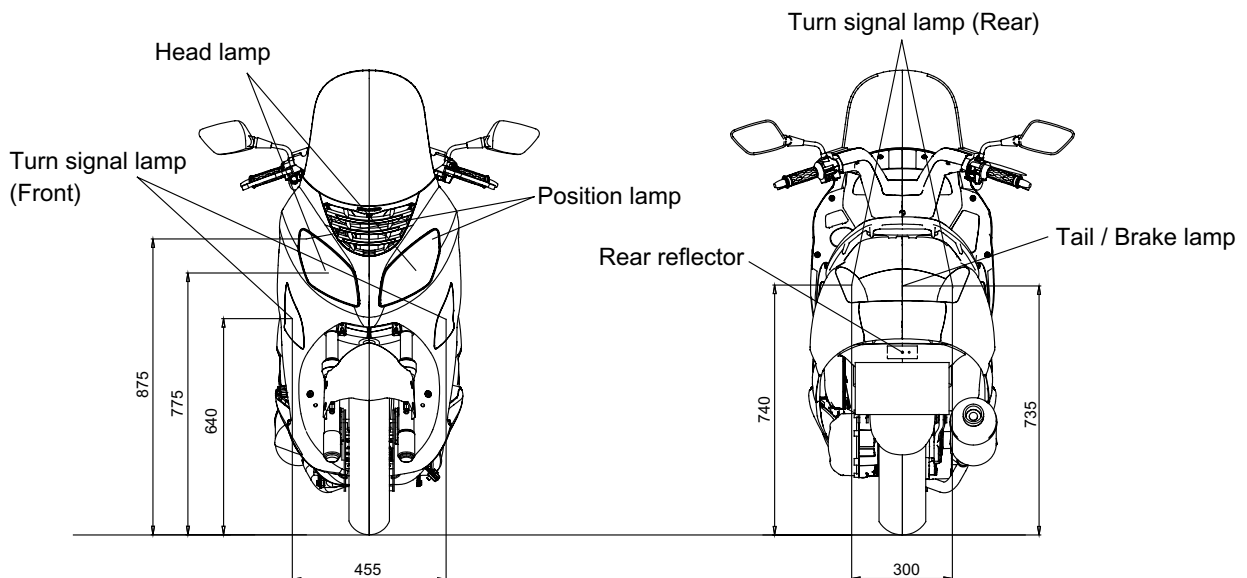
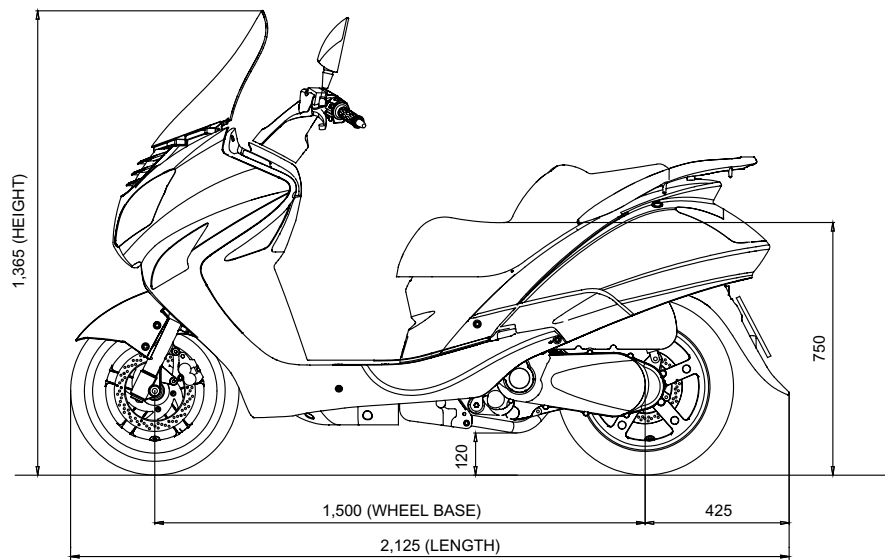
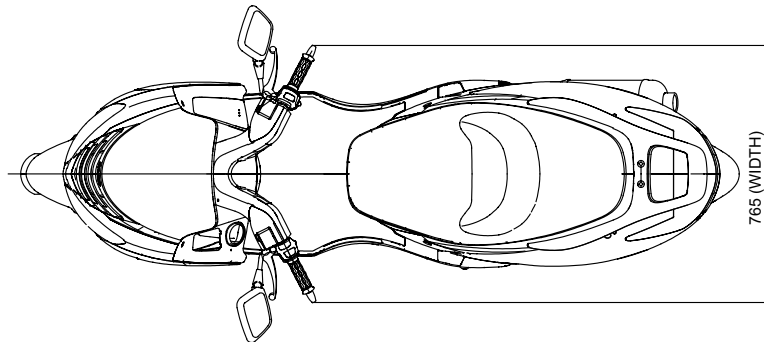

SPECIFICATIONS

⊙ DIMENSIONS AND DRY MASS

ITEM	MS3 250	MS3 125
Overall length	2,125 mm (83.7 in)	←
Overall width	765 mm (30.1 in)	←
Overall height	1,365 mm (53.7 in)	←
Wheelbase	1,500 mm (59.1 in)	←
Ground clearance	120 mm (4.7 in)	←
Mass	180 kg (397 lbs)	175 kg (386 lbs)

⊙ ENGINE

ITEM	MS3 250	MS3 125
Type	Four-stroke, DOHC, Liquid-cooled	←
Number of cylinder	1 cylinder	←
Bore	73.0 mm (2.87 in)	57.0 mm (2.24 in)
Stroke	59.6 mm (2.35 in)	48.8 mm (1.92 in)
Piston displacement	249.5 cm ³ (15.2 in ³)	124.5 cm ³ (7.6 in ³)
Fuel system	Fuel injection	←
Starter system	Electric starter	←
Lubrication system	Wet sump	←

⊙ TRANSMISSION

ITEM	MS3 250	MS3 125
Clutch	Dry shoe, automatic, centrifugal type	←
Reduction ratio	7.31	10.82
Transmission	0.900 ~ 2.333	0.804 ~ 2.414
Drive belt	V-belt drive	←

1-9 GENERAL INFORMATION

◎ CHASSIS

ITEM	MSB 250	MSB 125
Front suspension	Telescopic type	←
Rear suspension	Swingarm type	←
Steering angle	37 ° (right & left)	←
Caster	26 °	←
Trail	88.5 mm (3.5 in)	←
Front brake	Double disk brake	←
Rear brake	Disk brake	←
Front tire size	120/70 - 13M/C 53S	←
Rear tire size	140/60 - 14M/C 64S	←
Front fork stroke	85 mm (3.35 in)	←

◎ ELECTRICAL

ITEM	MSB 250	MSB 125
Ignition type	ECU	←
Ignition timing	10° B.T.D.C. at 2,000 rpm and 30° B.T.D.C. at 5,000 rpm	10° B.T.D.C. at 2,000 rpm and 28° B.T.D.C. at 4,000 rpm
Spark plug	CR8E	←
Battery	12V 8Ah (MF)	←
Fuse	Main : 30 A	←
	Head lamp : 15 A	←
Head lamp	HI : 12V - 55 W × 1	←
	LO : 12V - 55 W × 1	←
	Position : 12V - 5 W × 2	←
Turn signal lamp	LED type	←
Brake / Tail lamp	12V - 21 / 5 W × 1	←
License plate lamp	12V - 5 W × 1	←

※ LED : Light Emitting Diode

◎ CAPACITIES

ITEM	MSB 250	MSB 125
Fuel tank	8.0 ℓ	←
Engine oil, oil replace	800 ml	←
with oil filter replace	900 ml	←
overhaul	1,000 ml	←
Transmission oil, oil replace	400 ml	←
overhaul	410 ml	←
Coolant	1.15 ℓ	←
Front fork oil capacity (One side)	120 cc	←

NOTE

The specifications are subject to change without notice.

PERIODIC MAINTENANCE

CONTENTS

PERIODIC MAINTENANCE SCHEDULE	2- 1
PERIODIC MAINTENANCE CHART	2- 1
LUBRICATION POINTS	2- 4
MAINTENANCE PROCEDURES	2- 5
AIR CLEANER	2- 5
EXHAUST PIPE NUTS AND MUFFLER BOLTS	2- 6
VALVE CLEARANCE	2- 7
SPARK PLUG	2-10
FUEL HOSE	2-11
THROTTLE CABLE PLAY	2-11
ENGINE IDLE SPEED	2-11
ENGINE OIL AND OIL FILTER	2-12
TRANSMISSION OIL	2-14
ENGINE COOLANT	2-15
RADIATOR HOSE	2-17
BRAKE SYSTEM	2-18
STEERING	2-22
FRONT FORK	2-22
REAR SHOCK ABSORBER	2-22
TIRE	2-23
CHASSIS BOLTS AND NUTS	2-23
COMPRESSION PRESSURE	2-24
AUTOMATIC CLUTCH INSPECTION	2-25

PERIODIC MAINTENANCE SCHEDULE

The chart below lists the recommended intervals for all the required periodic service work necessary to keep the motorcycle operating at peak performance and economy.

⚠ CAUTION
More frequent servicing should be performed on motorcycles that are used under severe conditions.

PERIODIC MAINTENANCE CHART

■ ENGINE

Item \ Interval	Initial 1,000 km	Every 4,000 km	Every 8,000 km	page
Air cleaner element	Clean every 3,000 km · Replace every 12,000 km			2-5
Exhaust pipe nuts and muffler bolts	Tighten	Tighten	—	2-6
Valve clearance adjust	Inspect	Inspect	—	2-7
Cylinder head bolt	Tighten	Tighten	—	3-43
Cylinder head & Cylinder	—	—	Remove carbon	3-18
Spark plug	Clean	Clean	Replace	2-10
Fuel hose	Inspect	Inspect	—	2-11
	Replace every 4 years			
Engine oil filter	Replace	Replace	—	2-12
Engine oil	Replace	Replace	—	2-12
Throttle cable	Inspect	Inspect	—	2-11
Idle speed	Inspect	Inspect	—	2-11
Engine coolant	Replace every 2 years			2-15
Radiator hoses	—	Inspect	—	2-17
	Replace every 4 years			
Transmission oil	Inspect	—	Inspect	2-14
Drive belt	—	—	Inspect	3-34

■ CHASSIS

Item \ Interval	Initial 1,000 km	Every 4,000 km	Every 8,000 km	page
Brake	Inspect	Inspect	—	2-18
Brake hoses	Inspect	Inspect	—	2-18
	Replace every 4 years			
Brake fluid	Inspect	Inspect	—	2-18
	Replace every 2 years			
Tires	Inspect	Inspect	—	2-23
Steering	Inspect	Inspect	—	2-22
Front forks	—	Inspect	—	2-22
Rear shock absorber	—	Inspect	—	2-22
Chassis bolts and nuts	Tighten	Tighten	—	2-23
General lubrication	Lubricate	Lubricate	—	2-4

⚠ CAUTION
Using poor quality replacement parts can cause your motorcycle to wear more quickly and shorten its useful life. Use only genuine Hyoung replacement parts or their equivalent.

▣ SIDE COVER STAY

『*MSB 650 / 659*』have the “Side cover stay” inside the side cover.

Use the “Side cover stay” to inspect the engine or the other parts easily.

◆ USE OF SIDE COVER STAY

- Position the motorcycle on the center stand.
- Raise the seat.

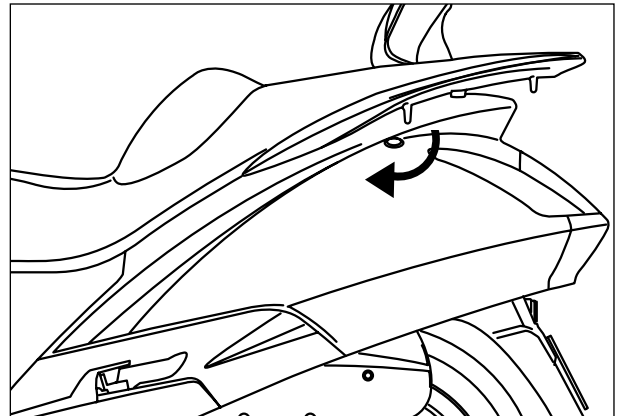

- Remove the two bolts ① in the personal trunk.

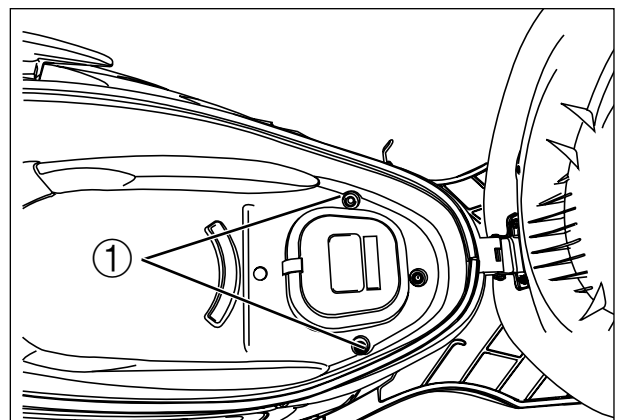

- Remove the two bolts ② of the rear carrier.
- Push the side cover for the rear side.

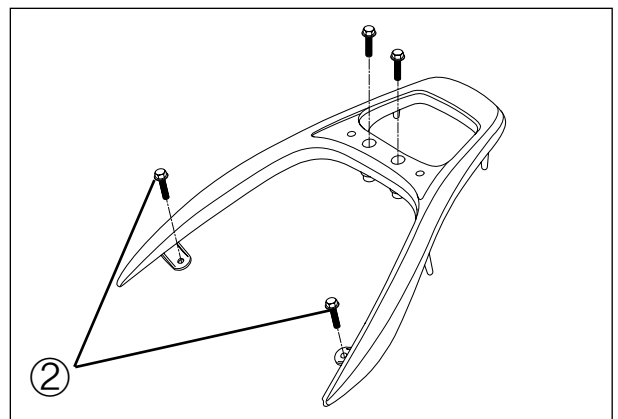

⚠ CAUTION

Proceed with care.
Do not damage the cover, reflector and lamp.
Handle plastic and paint-finished parts with care to avoid scratching or damage.

- Disconnect the tail lamp coupler.
- Lift the front end of the side cover and prop it up as shown side.
Insert the crank end of the side cover stay ③ into the hole of the side cover.

⚠ CAUTION

Upon reassembly, install the bolts and cover correctly in the appropriate seats.

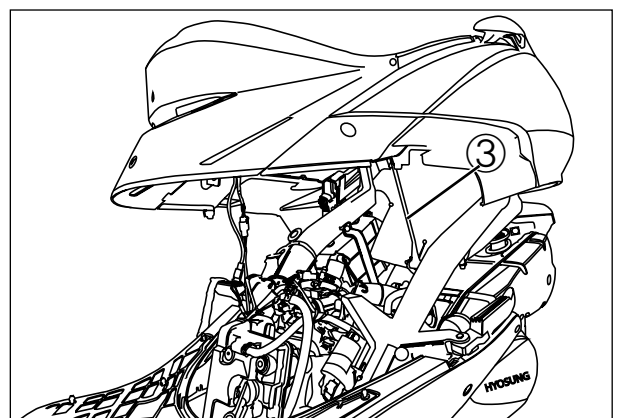

2-3 PERIODIC MAINTENANCE

▣ HELMETBOX INNER COVER

『*MSB 650/125*』 have the “Helmetbox inner cover” inside the personal trunk.

Use the “Helmetbox inner cover” to inspect the fuel injection system easily.

◆ USE OF HELMETBOX INNER COVER

- Position the motorcycle on the center stand.
- Raise the seat.

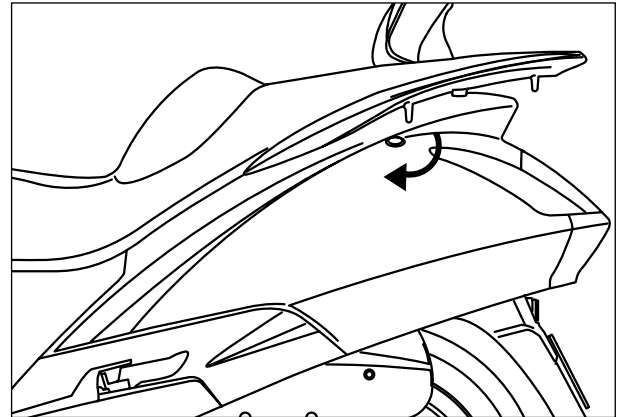

- Lift the helmetbox inner cover knob ① carefully.



CAUTION

Proceed with care.

Do not damage the personal trunk and helmetbox inner cover.

Handle plastic parts with care to avoid damage.

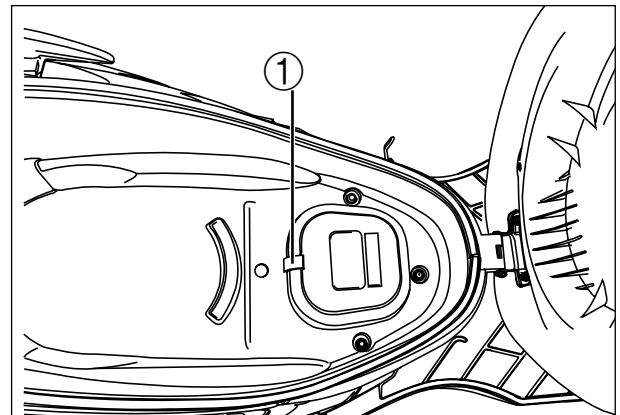

LUBRICATION POINTS

Proper lubrication is important for smooth operation and long life of each working part of the motorcycle. Major lubrication points are indicated below.

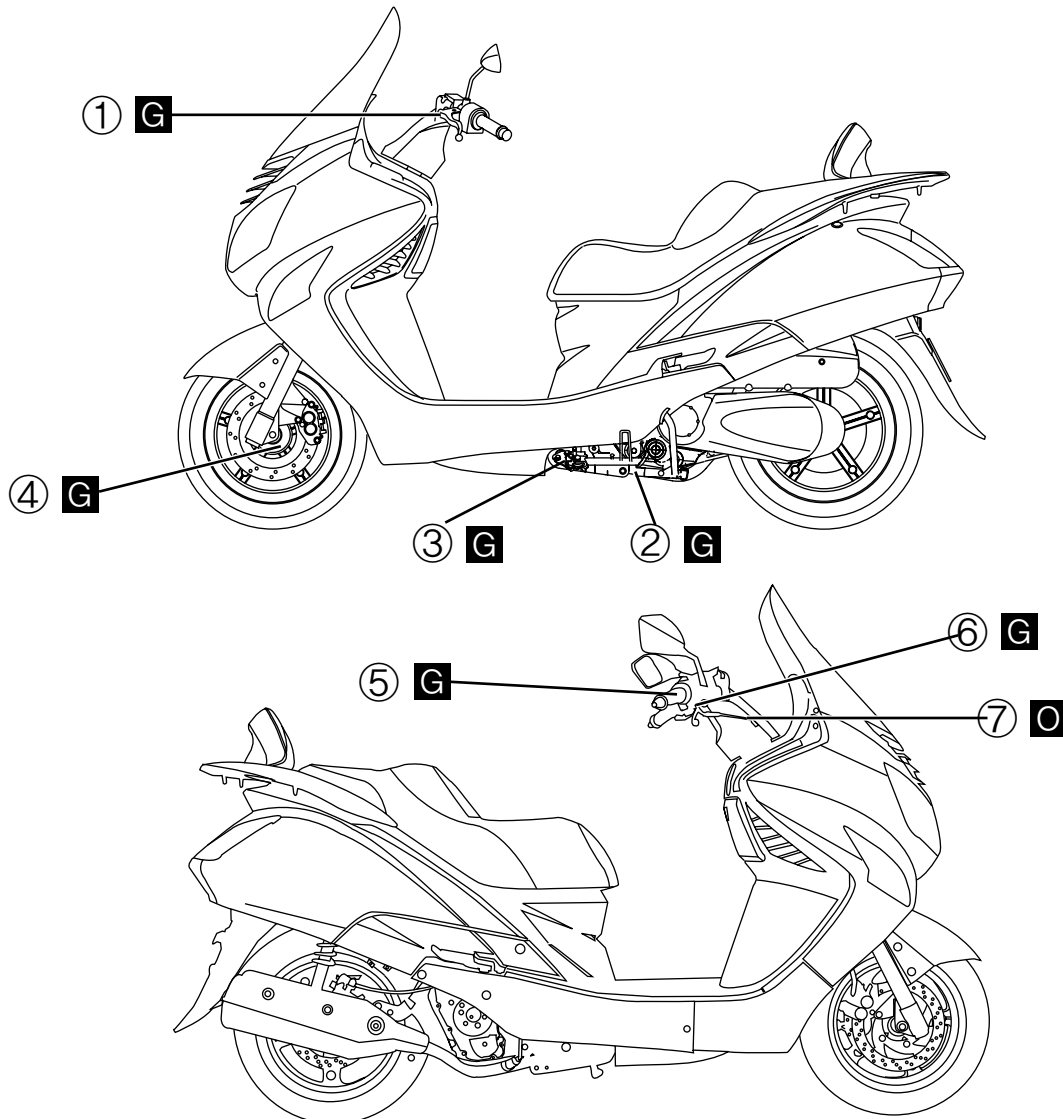

- | | |
|--------------------------------------|----------------------------|
| ① Rear brake lever holder | ⑤ Throttle grip |
| ② Center stand pivot and spring hook | ⑥ Front brake lever holder |
| ③ Side stand pivot and spring hook | ⑦ Throttle cable |
| ④ Speedometer gear box | ⓪ - Motor oil, Ⓜ - Grease |

NOTE

- ❖ Before lubricating each part, clean off any rusty spots and wipe off any grease, oil, dirt or grime.
- ❖ Lubricate exposed parts which are subject to rust, with either motor oil or grease whenever the motorcycle has been operated under wet or rainy condition.

MAINTENANCE PROCEDURES

This section describes the servicing procedures for each item mentioned in the Periodic Maintenance chart.

AIR CLEANER

Inspect Interval

**Clean Every 3,000 km,
Replace Every 12,000 km.**

If the air cleaner is clogged with dust, intake resistance will be increased, with a resultant decrease in power output and an increase in fuel consumption.

Check and clean the air cleaner element in the following manner :

- Position the motorcycle on the center stand.
- Lift and support the side cover with the side cover stay. (Refer to page 2-2)
- Unscrew and remove the eight screws ① .
- Remove the air cleaner case cover ② .
- Take off the air cleaner element ③ .

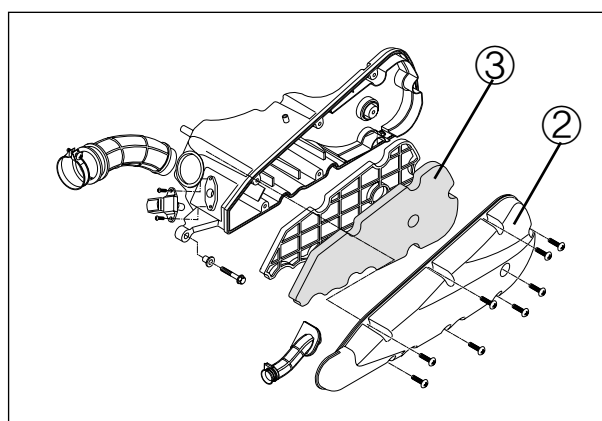
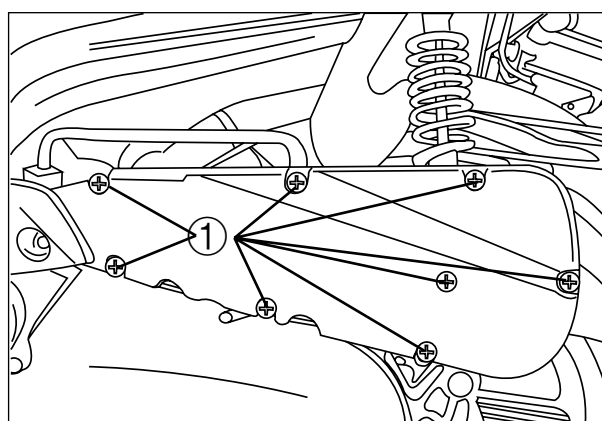
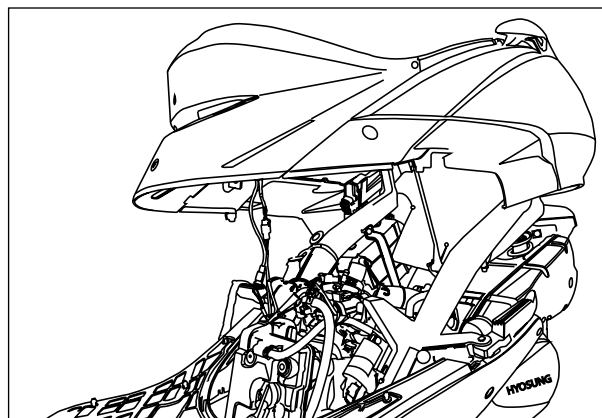

- Fill a washing pan of a proper size with a non-flammable cleaning solvent ①. Immerse the air cleaner element in the cleaning solvent and wash it.
- Gently squeeze the air cleaner element between the palms of both hands to remove the excess solvent : do not twist or wring the element or it will develop tears.
- Immerse the element in HYOSUNG genuine oil ②, and then squeeze out the excess oil leaving the element slightly wet.
- Reinstall the cleaned or new air cleaner element in the reverse order of removal.

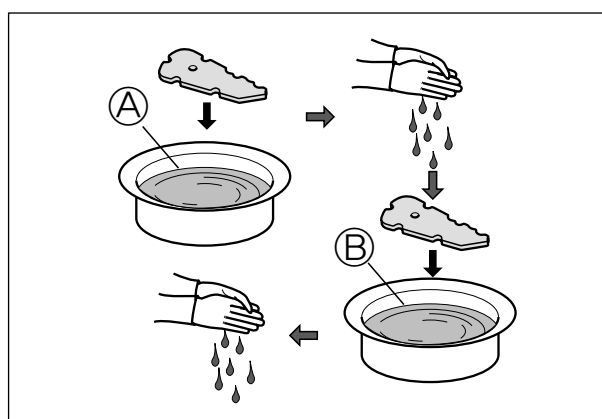

⚠ CAUTION

- ❖ Inspect the air cleaner element for tears. A torn element must be replaced.
- ❖ If driving under dusty conditions, clean the air cleaner element more frequently. The surest way to accelerate engine wear is to operate the engine without the element or with torn element. Make sure that the air cleaner element is in good condition at all times. Life of the engine depends largely on this component!

▣ OIL RETURN TANK DRAIN PLUG

Inspect the plug ① and drain water and oil at the periodic interval.

The oil return tank drain plug ① is located the side of the oil return tank.

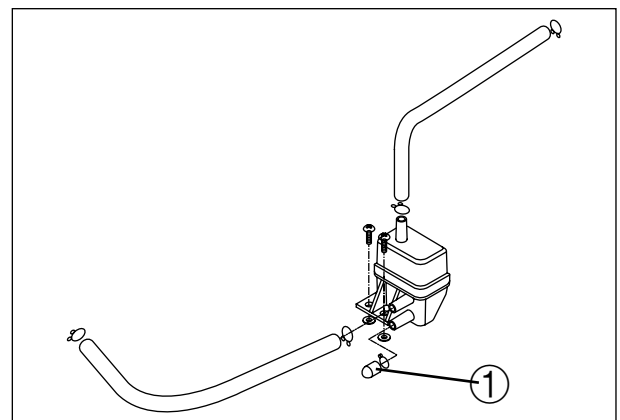

EXHAUST PIPE NUTS AND MUFFLER BOLTS

Inspect Interval

Tighten Initial at 1,000 km and Every 4,000 km thereafter.

- Tighten the exhaust pipe nuts (A), muffler connecting bolt (B), and muffler mounting bolts (C), (D) to the specified torque.

🔧 Exhaust pipe nut : 23 N · m (2.3 kgf · m)

**Muffler connecting bolt
: 20 N · m (2.0 kgf · m)**

**Muffler mounting bolt
: 18 ~ 28 N · m (1.8 ~ 2.8 kgf · m)**

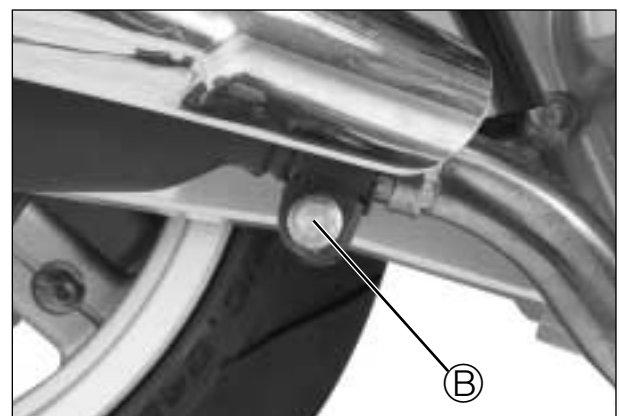
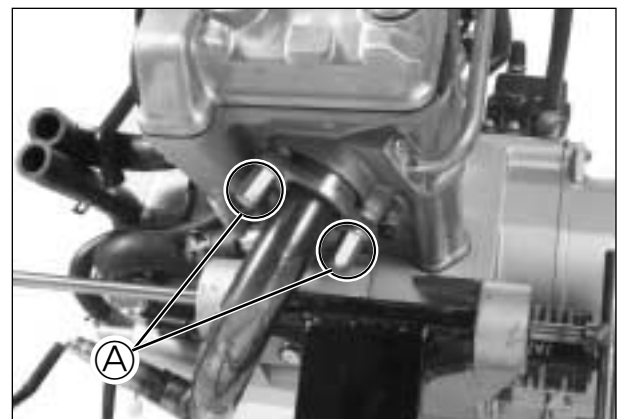

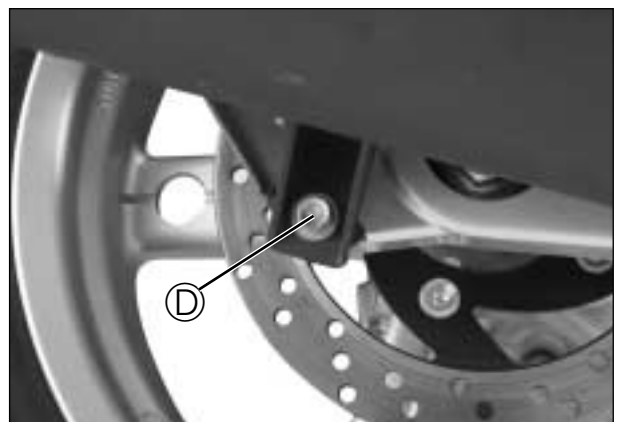
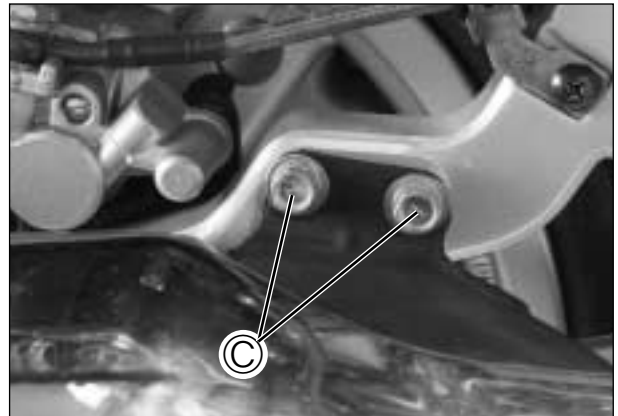
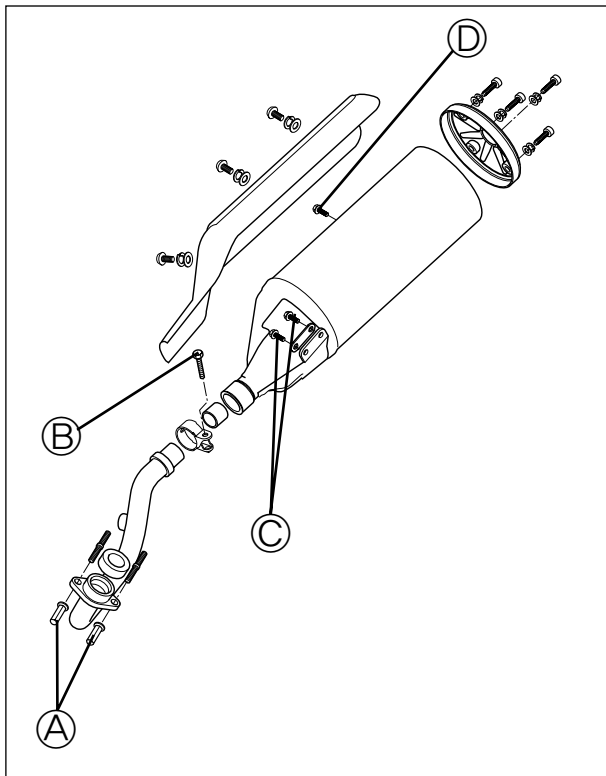

VALVE CLEARANCE

Inspect Interval

Inspect Initial 1,000 km and Every 4,000 km thereafter.

Excessive valve clearance results in valve noise and insufficient valve clearance results in valve damage and reduced power.

Check the intake and exhaust valve clearances at the distances indicated above and adjust the valve clearances to specification, if necessary.

- Lift and support the side cover with the side cover stay. (Refer to page 2-2)
- Remove the spark plug.
- Disconnect the breather hose ①.

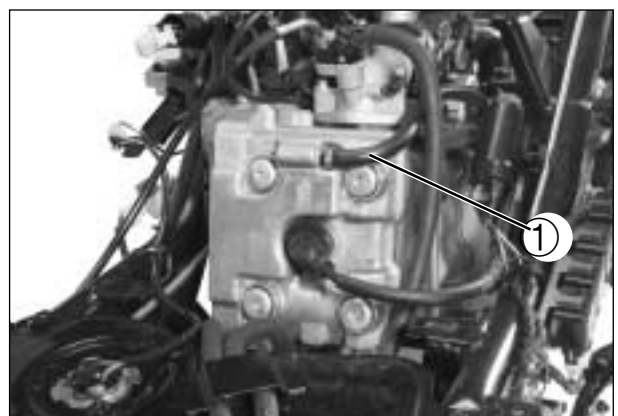

- Remove the cylinder head cover.

The valve clearance specification is different for both intake and exhaust valves.

Valve clearance adjustment must be checked and adjusted :

- 1) at the time of periodic inspection,
- 2) when the valve mechanism is serviced, and
- 3) when the camshafts are removed for servicing.

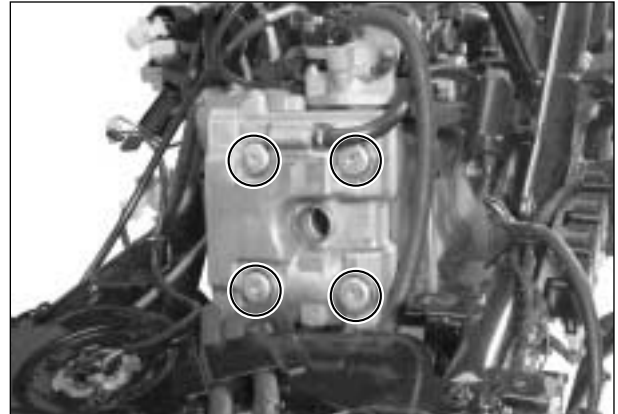

- Remove the valve timing inspection plug ① .

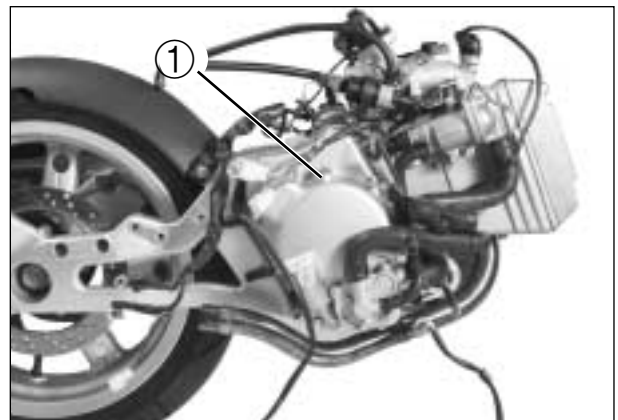

- Remove the crankcase cleaner case ② .

NOTE

- ❖ *The piston must be at top dead center (TDC) on the compression stroke in order to check or adjust the valve clearance.*
- ❖ *The valve clearance should only be checked when the engine is cold.*

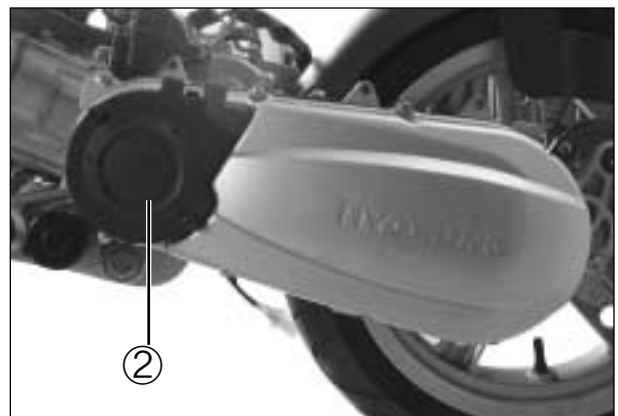

2-9 PERIODIC MAINTENANCE

- Rotate the crankshaft clockwise with a socket wrench to set the piston at TDC on the compression stroke.
(Rotate the crankshaft until the “—” line on the magneto rotor is aligned with the triangle mark on the magneto cover.)

- To inspect the valve clearance, insert a thickness gauge between the tappet and the camshaft.

Valve clearance	Standard (When cold)
IN.	0.10 ~ 0.20 mm (0.004 ~ 0.008 in)
EX.	0.20 ~ 0.30 mm (0.008 ~ 0.012 in)

 **Thickness gauge : 09900-20806**

- If the clearance is out of specification, first remove the cam chain tension adjuster, camshaft housing, camshaft.
To install the tappet shim at original position, record the shim NO. and clearance to present by “A”, “B”, “C”, “D” mark on the cylinder head.

Select the tappet that agree with tappet clearance (vertical line) and shim NO.(horizontal line) as refer to the tappet shim selection chart.
(Refer to page 9-37 · 38)

Adjust valve timing, install the camshaft housing and the tension adjuster.

After the crankshaft rotate about 10 times, measure the valve clearance.

If the clearance be not correct, adjust the standard clearance as the same manner above.

- In case of valve adjustment which is not the tappet shim selection chart, please follow instructions of example in the below.

For example, the intake clearance is 0.4 and the shim is 170 (1.70 mm), select 195 (1.95 mm) of the shim which 170 (1.70 mm) of the shim add up the excess clearance 0.25 mm when adjust with the standard 0.15 as the intake standard clearance 0.1 ~ 0.2 mm.

CAUTION

If you don't rotate the crankshaft about 10 times before measuring the valve clearance, there is no meaning of valve clearance.

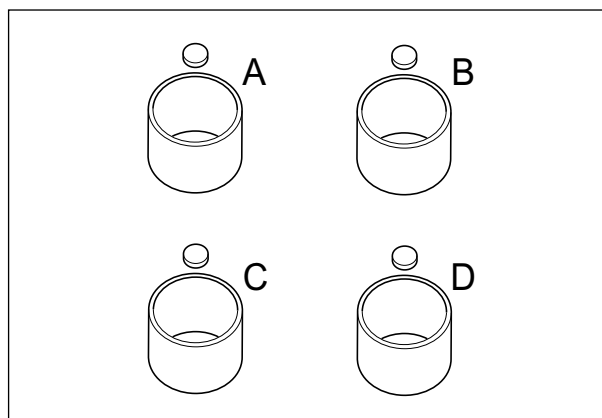
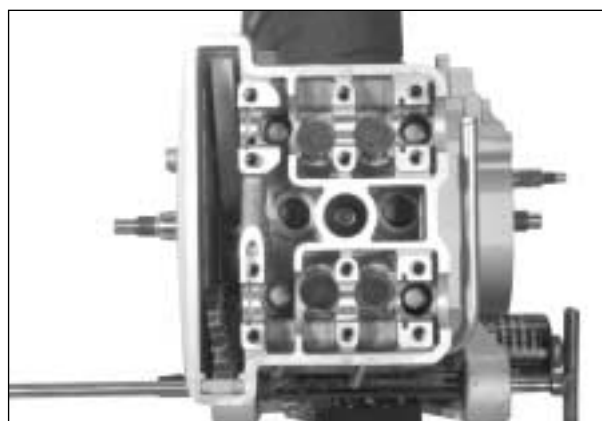
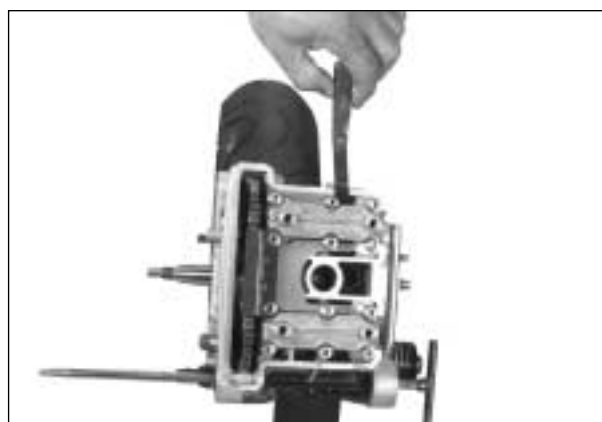

SPARK PLUG

Inspect Interval

*Clean Initial 1,000 km and Every 4,000 km thereafter.
Replace Every 8,000 km.*

- Disconnect the spark plug cap ① and remove the spark plug.

TYPE	SPARK PLUG SPECIFICATION
Hot type	CR7E
Standard type	CR8E
Cold type	CR9E

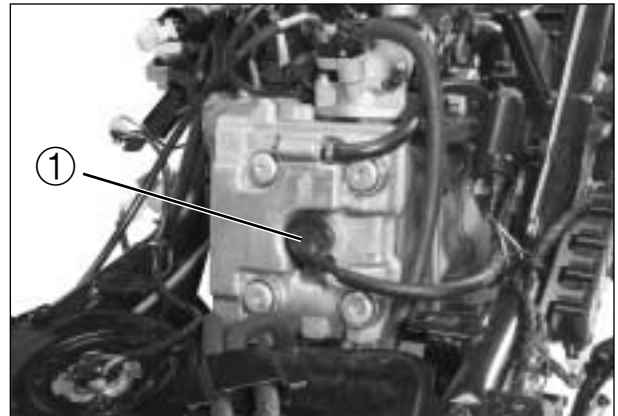

▣ CARBON DEPOSITS

Check to see if there are carbon deposits on the spark plug.

If carbon is deposited, remove it using a wire or pin with a pointed end.

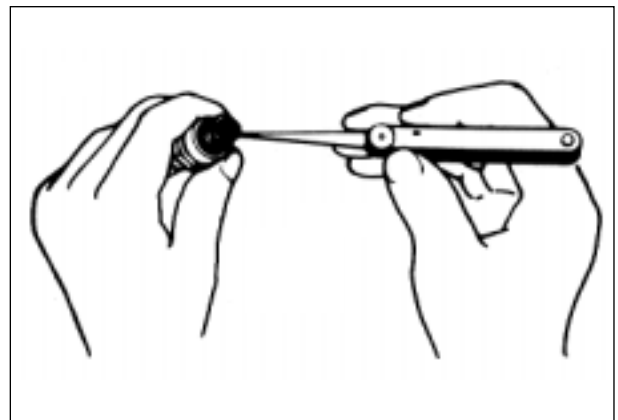

▣ SPARK PLUG GAP

Measure the spark plug gap using a thickness gauge.

If the spark plug gap is out of specification, adjust the gap.

Spark plug gap	0.7 ~ 0.8 mm (0.028 ~ 0.032 in)
-----------------------	---------------------------------

 **Thickness gauge : 09900-20806**

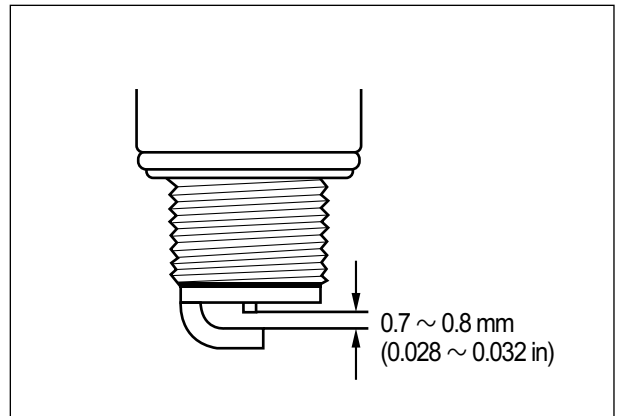

▣ ELECTRODE

Check to see the worn or burnt condition of the electrodes.

If it is extremely worn or burnt, replace the spark plug with a new one.

And also replace the spark plug if it has a broken insulator, damaged thread, etc.

⚠ CAUTION

To avoid damaging the cylinder head threads ; first, finger tighten the spark plug, and then tighten it to the specified torque using the spark plug wrench.

- Insert the spark plug and finger tighten it to the cylinder head and then tighten it to the specified torque.

🔧 Spark plug

: 20 ~ 25 N · m (2.0 ~ 2.5 kgf · m)

FUEL HOSE

Inspect Interval

Inspect Initial 1,000 km and Every 4,000 km thereafter. Replace Every 4 years.

Inspect the fuel hose for damage and fuel leakage. If any damages are found, replace the fuel hoses with a new one.

THROTTLE CABLE PLAY

Inspect Interval

Inspect Initial 1,000 km and Every 4,000 km thereafter.

Adjust the throttle cable play (A) as follows.

- Position the motorcycle on the center stand.
- Withdraw the protection.
- Loosen the lock nut ① of the throttle cable.
- Turn the adjuster ② in or out to obtain the correct play.

Throttle cable play (A) 0.5 ~ 1.0 mm (0.02 ~ 0.04 in)

- After adjusting the throttle cable play, tighten the lock nut ① .
- Check the throttle cable play again.
- Refit the protection.

ENGINE IDLE SPEED

Inspect Interval

Inspect Initial 1,000 km and Every 4,000 km thereafter.

NOTE

Make this adjustment when the engine is warmed up.

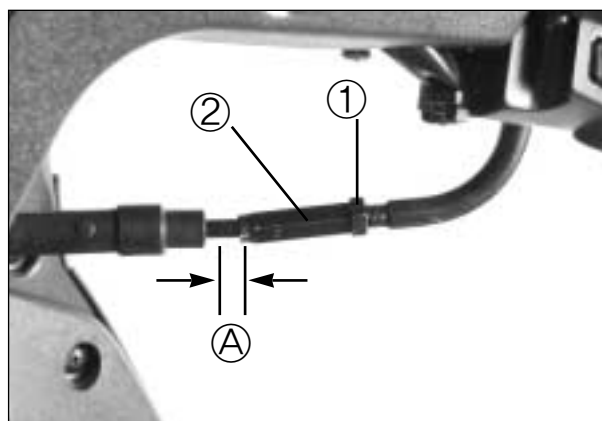

- Remove the helmetbox inner cover. (Refer to page 2-3)
- Connect the engine tachometer to the high-tension cord.
- Start the engine and inspect the engine idle speed between specified range.

Engine	<i>MSB 250</i>	<i>MSB 125</i>
idle speed	1,400 ~ 1,600 rpm	1,350 ~ 1,550 rpm

 Engine tachometer : 09900-26006

 **CAUTION**

Never operate the idle screw ① and throttle lever stopper screw ② to avoid variations of the carburetion setting.

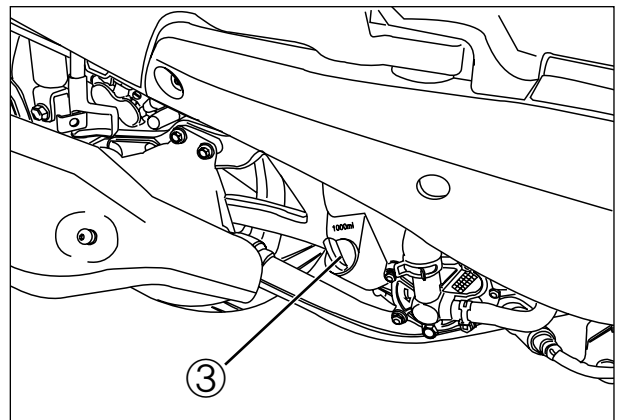
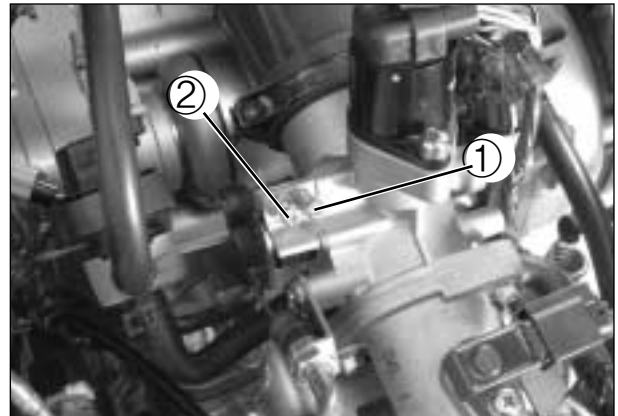

ENGINE OIL AND OIL FILTER

Inspect Interval

Replace Initial 1,000 km and Every 4,000 km thereafter.

The oil should be changed while the engine is warm. Oil filter replacement at the above intervals, should be done together with the engine oil change.

ENGINE OIL AND OIL FILTER REPLACEMENT

- Keep the motorcycle upright with the center stand.
- Place an oil drain pan below the engine.
- Remove the engine oil level gauge ③ .
- Drain the engine oil by removing the engine oil drain plug ④ located on the left downside of the engine.

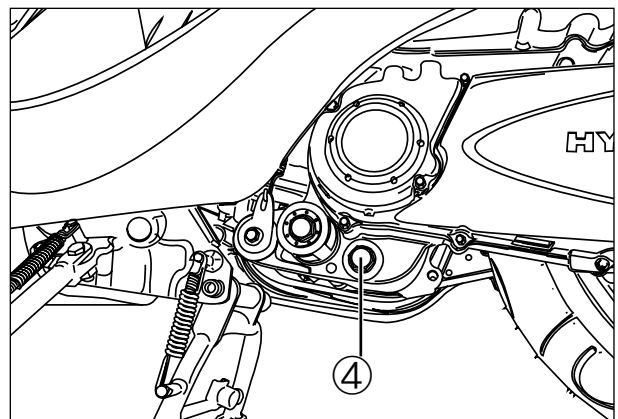

 **CAUTION**

Necessarily, confirm and clean the oil strainer A when replace the engine oil (specially, when first replacement).

 **CAUTION**

More frequent servicing may be performed on motorcycle that are used under severe conditions.

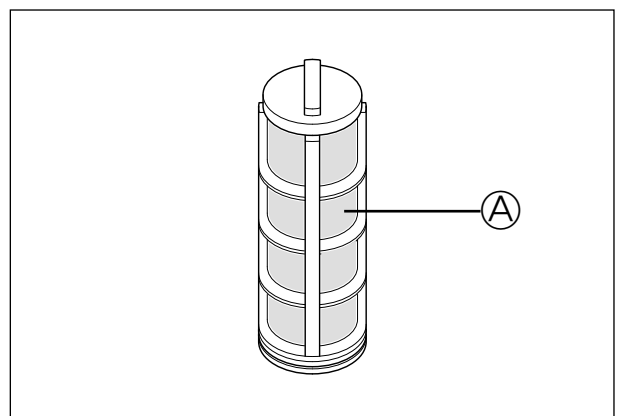

2-13 PERIODIC MAINTENANCE

- Reinstall the engine oil drain plug ①, and O-ring. Tighten the engine oil drain plug ① to the specified torque.

Engine oil drain plug

: 35 ~ 45 N · m (3.5 ~ 4.5 kgf · m)

- Loosen the engine oil filter ② counter-clockwise and remove it with a 17mm socket wrench.
- Wipe off the mounting surface on the engine where the new engine oil filter will be seated with a clean rag.
- Smear a little engine oil around the rubber gasket of the new engine oil filter.
- Screw on the new engine oil filter by hand until the filter gasket contacts the mounting surface (a small resistance will be felt).



CAUTION

When reassembling the oil filter, make sure that the oil filter is installed.

If the filter is installed improperly, serious engine damage may result.

- Pour the new engine oil through the oil filler hole. When performing an oil change (with oil filter replacement), the engine will hold about 900 ml of oil. Use an engine oil that meets the API service classifications of over SL and that has a viscosity rating of SAE 10W/40.

Necessary amount of engine oil

Oil change	800 ml
Oil and filter change	900 ml
Engine overhaul	1,000 ml
Engine oil type	SAE 10W / 40 API Over SL

- Install the oil level gauge ③.
- Start the engine and allow it to run for a few minutes at idling speed.
Check to see that no oil is leaking from the oil filter and drain plug.
- Turn off the engine and wait about three minutes, and then check the oil level on the dipstick ④. (Remove the engine oil level gauge ③. Wipe the oil from the oil level gauge using a clean rag. Reinsert the oil level gauge until the threads touch filler neck, but do not screw the oil level gauge in.) If the level is below upper limit line, add oil to that level. The motorcycle must be in a level position for accurate measurement.

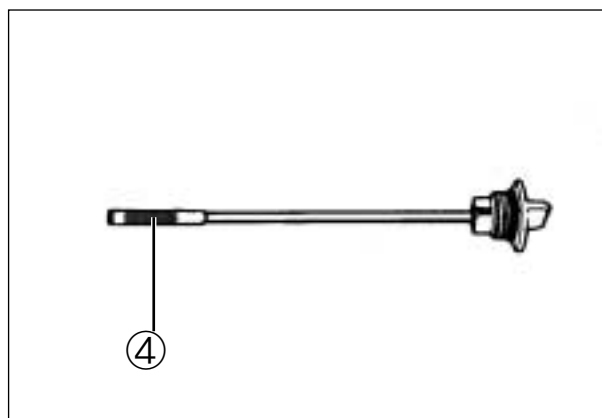
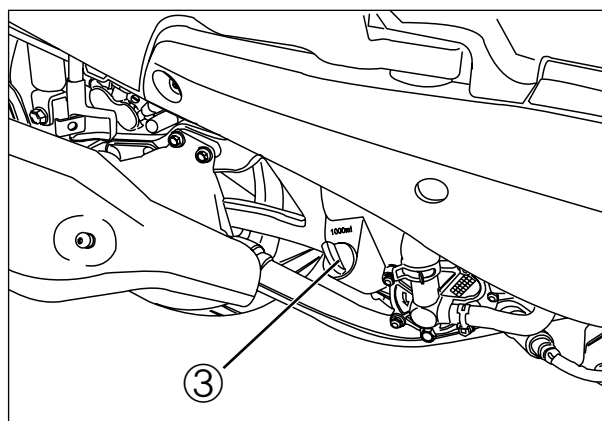
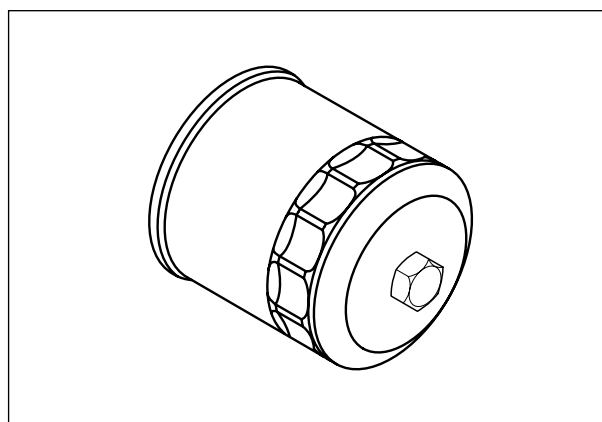
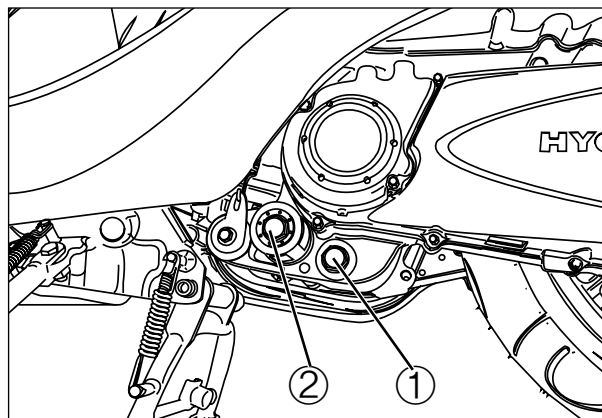

TRANSMISSION OIL

Inspect Interval

Inspect Initial 1,000 km and Every 8,000 km thereafter.

TRANSMISSION OIL REPLACEMENT

After a long period of use, the transmission oil qualities will deteriorate and quicken the wear of sliding and interlocking surfaces. Replace the transmission oil periodically following the procedure below.

- Keep the motorcycle upright with the center stand.
- Start the engine to warm up the oil, this will facilitate draining oil.
- Place a drain pan under the engine.
- Remove the transmission oil filler cap ① .
- Release and remove the transmission oil level bolt ② and oil drain bolt ③ .
- Let all transmission oil drain out.
Collect it in a drain pan with adequate capacity.
- Fit and tighten the transmission oil drain bolt ③ to the specified torque.

Transmission oil drain bolt

: 12 N · m (1.2 kgf · m)

- Fill about 400 ml of the specified oil through the transmission oil filler hole.

TRANSMISSION OIL CAPACITY	
CHANGE	400 ml
OVERHAUL	410 ml

- Install the transmission oil filler cap ① .
- Check the transmission oil level using the transmission oil level bolt hole and top up as required without exceeding the transmission oil level bolt hole.
- Tighten the transmission oil level bolt ② to the specified torque.

Transmission oil level bolt

: 12 N · m (1.2 kgf · m)

- Operate the engine a few minutes by idling speed. Inspect the oil leakage at the transmission oil drain bolt and oil level bolt.

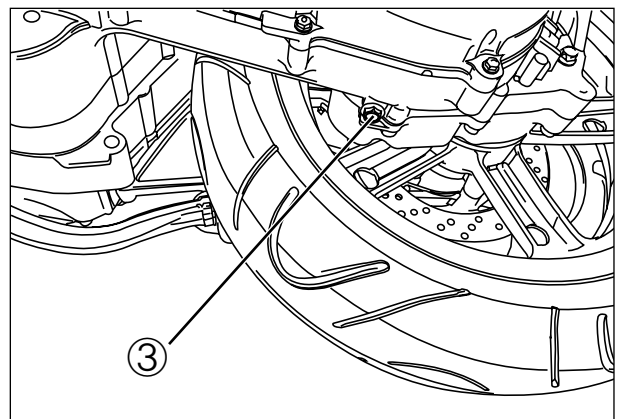
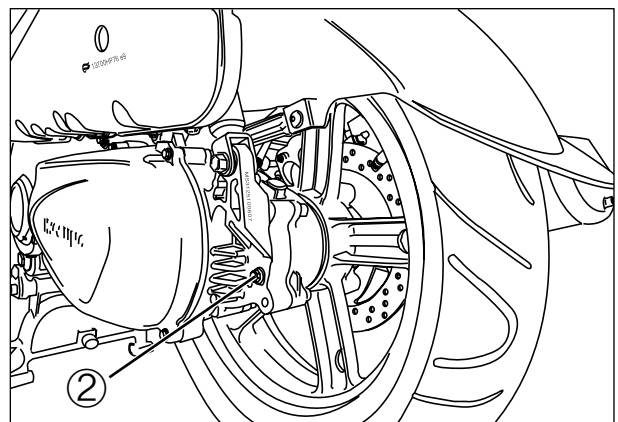
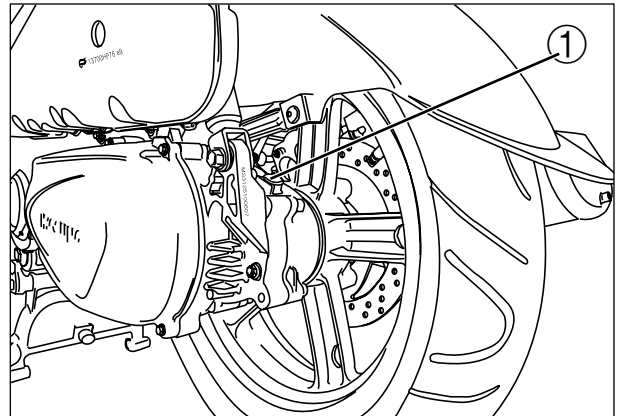

ENGINE COOLANT

Inspect Interval

Replace Every 2 years.

ENGINE COOLANT LEVEL CHECK

- Keep the motorcycle upright.
- Check the engine coolant level by observing the "F"(FULL) and "L"(LOW) level lines on the engine coolant reservoir tank through the front frame cover.
- If the level is below the "L"(LOW) level line, add engine coolant until the level reaches the "F"(FULL) level line.

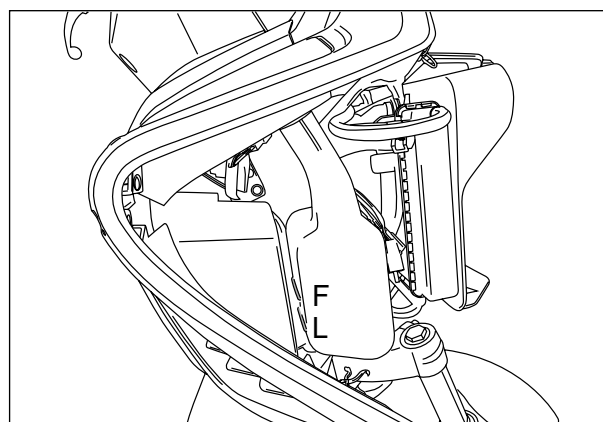
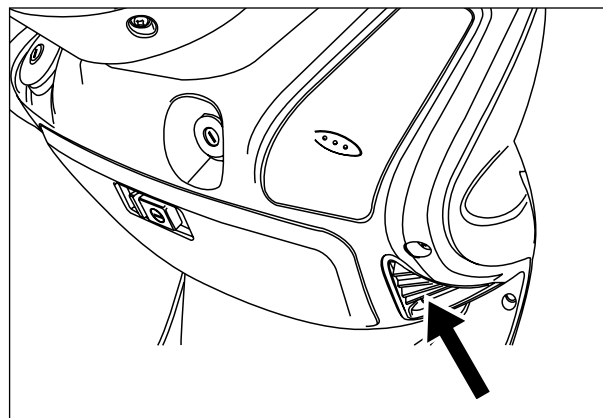

OPEN THE RADIATOR CAP

Remove the radiator cap cover ① to operate the radiator cap ③.

To disassemble the radiator cap cover ①, remove the mounting bolt ②.

⚠ WARNING

You can be injured by scalding fluid or steam if you open the radiator cap when engine is hot. After the engine cools, wrap a thick cloth around cap and carefully remove the cap by turning it a quarter to allow pressure to escape and then turn the cap all the way off.

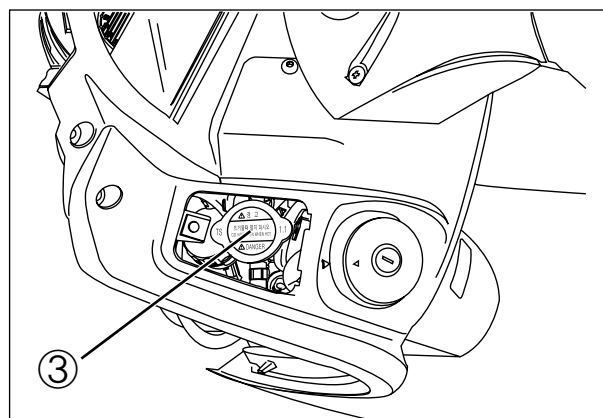
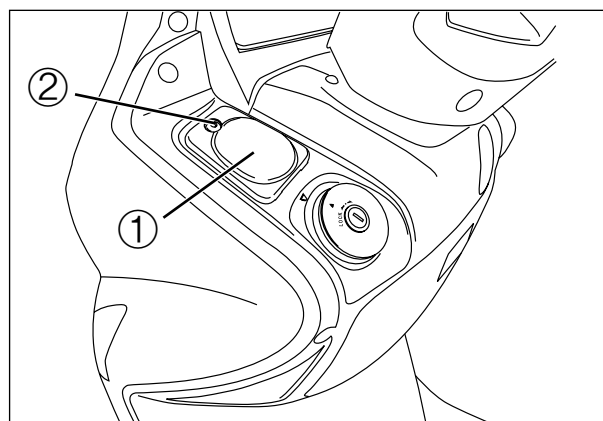

ENGINE COOLANT REPLACEMENT

- Remove the radiator cap cover.
- Remove the radiator cap ①.
- Open the coolant reservoir tank filler cap cover ② by light pressing.
- Remove the coolant reservoir tank filler cap ③.
- Place a pan below the water pump, and then drain the engine coolant by removing the drain bolt ④.

⚠ WARNING

- ❖ Do not open the radiator cap when the engine is hot, as you may be injured by escaping hot liquid or vapor.
- ❖ Engine coolant may be harmful if swallowed or if it comes in contact with the skin or eyes. If engine coolant gets into the eyes or contacts the skin, flush the eyes or wash the skin thoroughly, with plenty of water. If engine coolant is swallowed, induce vomiting and call a physician immediately.

- Flush the radiator with fresh water, if necessary.
- Tighten the coolant drain bolt ④ to the specified torque.

🔧 Coolant drain bolt

: 11 ~ 14 N · m (1.1 ~ 1.4 kgf · m)

- Pour the specified engine coolant through the radiator cap inlet up to the inlet neck.

NOTE

For engine coolant information, refer to page 6-1.

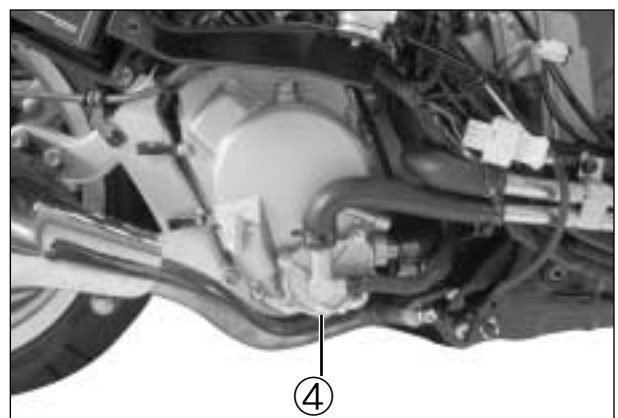
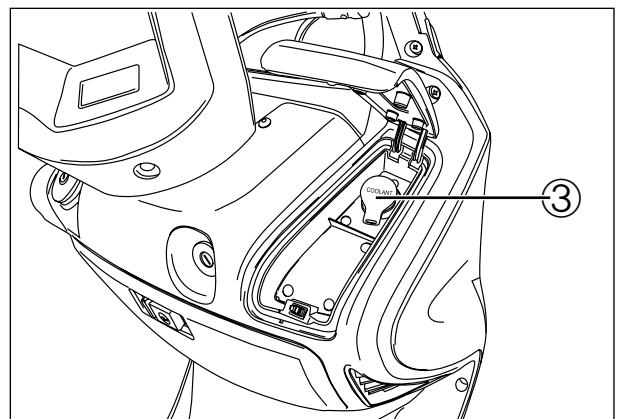
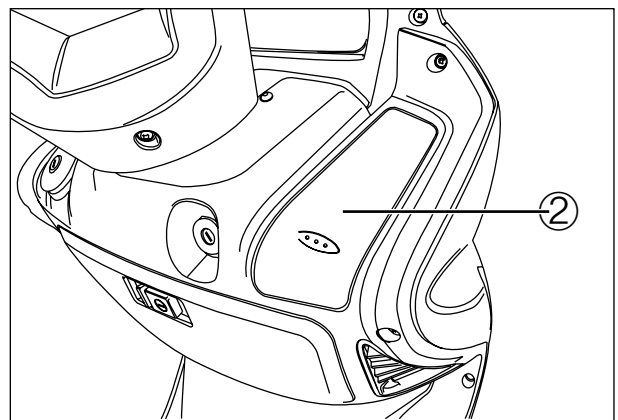
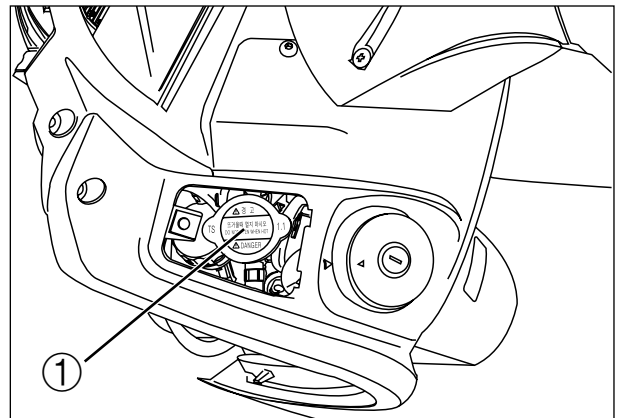

- Bleed the air from the engine coolant circuit as following procedure.

2-17 PERIODIC MAINTENANCE

▣ AIR BLEEDING THE COOLING CIRCUIT

- Add engine coolant up to the radiator cap inlet.
- Support the motorcycle upright.
- Slowly swing the motorcycle, right and left, to bleed the air trapped in the cooling circuit.
- Add engine coolant up to the radiator cap inlet.
- Loosen the connector bolt ① of the thermostat.
- Start up the engine and bleed air from the radiator cap inlet and the connector bolt of the thermostat completely.
- Add engine coolant up to the radiator cap inlet.
- Repeat the above procedure until no air bleed from the radiator cap inlet.
- Close the radiator cap securely.
- After warming up and cooling down the engine several times, add the engine coolant up to the "F"(FULL) level line of the reserve tank.

⚠ CAUTION

Repeat the above procedure several times and make sure that the radiator is filled with engine coolant up to the "F"(FULL) level line of the reserve tank.

**Engine coolant capacity
(including reserve)**

1.15ℓ

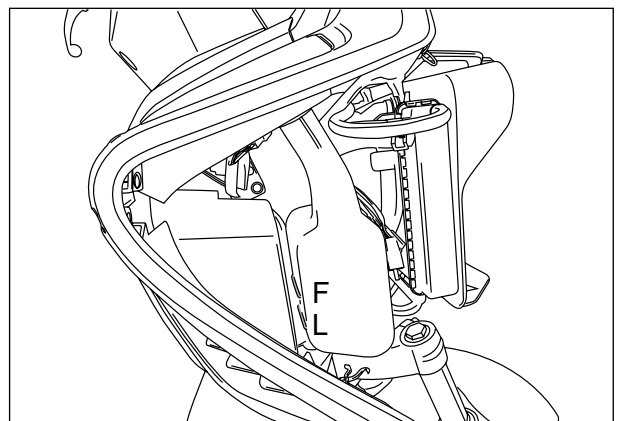
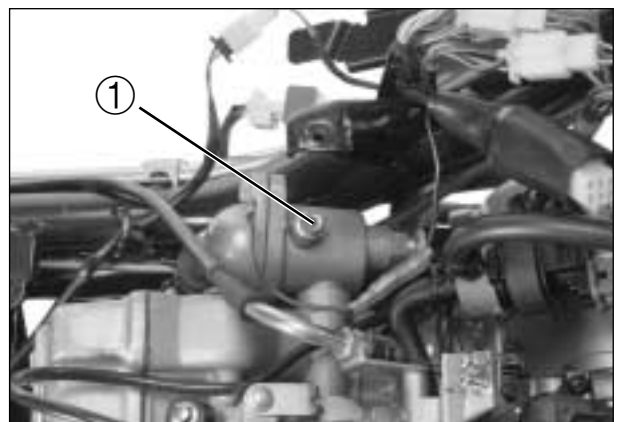

RADIATOR HOSE

Inspect Interval

*Inspect Every 4,000km,
Replace Every 4 years.*

Inspect the radiator hoses for crack, damage or engine coolant leakage.

If any damages are found, replace the radiator hoses with new ones.



BRAKE SYSTEM

Inspect Interval

[BRAKE]

Inspect Initial 1,000 km and Every 4,000 km thereafter.

[BRAKE HOSES & BRAKE FLUID]

Inspect Initial 1,000 km and Every 4,000 km thereafter.

Replace the brake hoses Every 4 years,

Replace the brake fluid Every 2 years.

▣ BRAKE FLUID LEVEL CHECK

- Keep the motorcycle upright and place the handlebars straight.
- Check the brake fluid level by observing the lower limit line (LOWER) on the front and rear brake fluid reservoir.
- When the level is below the lower limit line (LOWER), replenish with brake fluid that meets the following specification.

 **Specification and Classification : DOT 4**

WARNING

The brake system of these motorcycles are filled with a glycol-based brake fluid. Do not use or mix different types of fluid such as silicone-based or petroleum-based. Do not use any brake fluid taken from old, used or unsealed containers.

Never re-use brake fluid left over from the last servicing or stored for a long period.

WARNING

Brake fluid, if it leaks, will interfere with safe running and immediately discolor painted surfaces. Check the brake hoses and hose joints for cracks and oil leakage before riding.

▣ BRAKE PAD WEAR

The extend of brake pad wear can be checked by observing the grooved limit  on the pad. When the wear exceeds the grooved limit, replace the pads with new ones.

CAUTION

Replace the brake pad as a set, otherwise braking performance will be adversely affected.

CAUTION

Do not spill any brake fluid on the brake pad of disk.

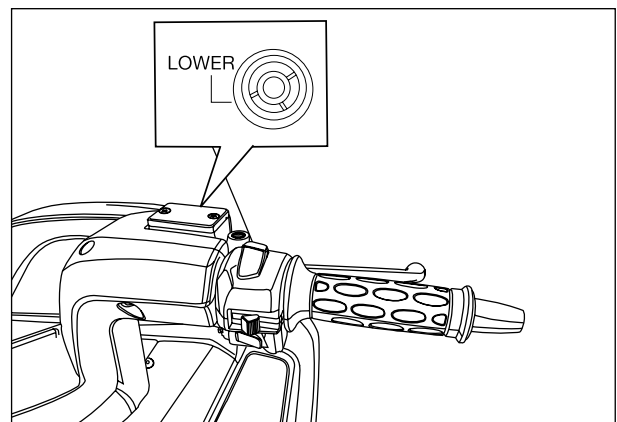

[Front Brake]

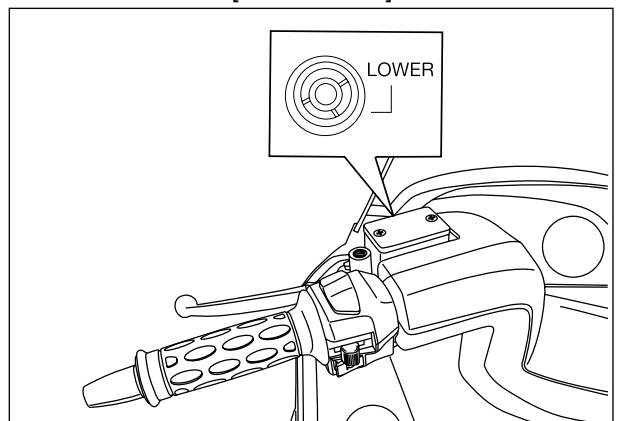

[Rear Brake]

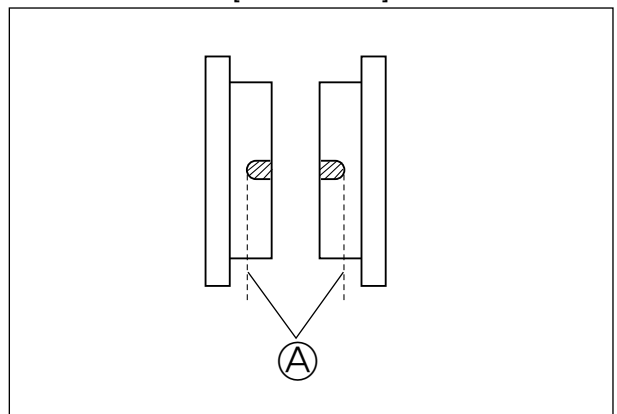

▣ FRONT AND REAR BRAKE PAD REPLACEMENT

- Remove the brake caliper.
- Remove the brake pads.
- To reassemble, reverse the above sequence.

🔧 **Front brake caliper mounting bolt**
: 18 ~ 28 N · m (1.8 ~ 2.8 kgf · m)

Rear brake caliper mounting bolt
: 18 ~ 28 N · m (1.8 ~ 2.8 kgf · m)



[Left side of Front Brake]



[Right side of Front Brake]

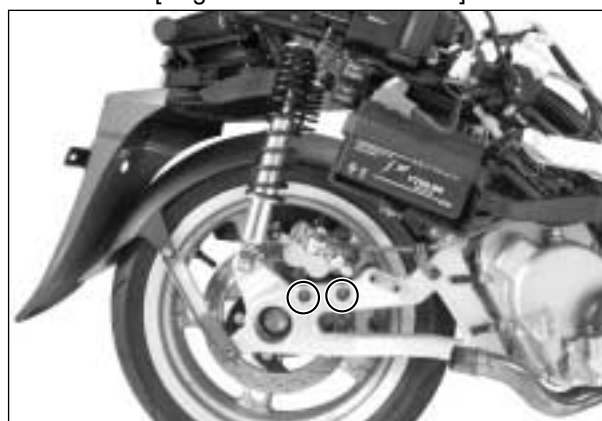

[Rear Brake]

▣ FRONT AND REAR BRAKE FLUID REPLACEMENT

- Place the motorcycle on a level surface and keep the handlebars straight.
- Remove the master cylinder reservoir cap and diaphragm.
- Suck up the old brake fluid as much as possible.
- Fill the reservoir with new brake fluid.

🛢️ **Specification and Classification : DOT 4**

- Connect a transparent hose ① to the air bleeder valve and insert the other end of the hose into a receptacle.

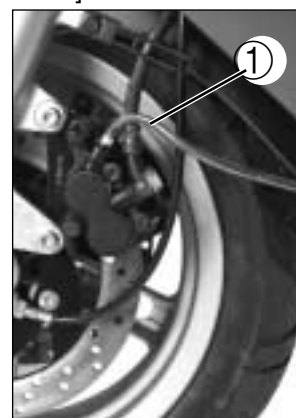

- Loosen the air bleeder valve and pump the brake lever until the old brake fluid is completely out of the brake system.

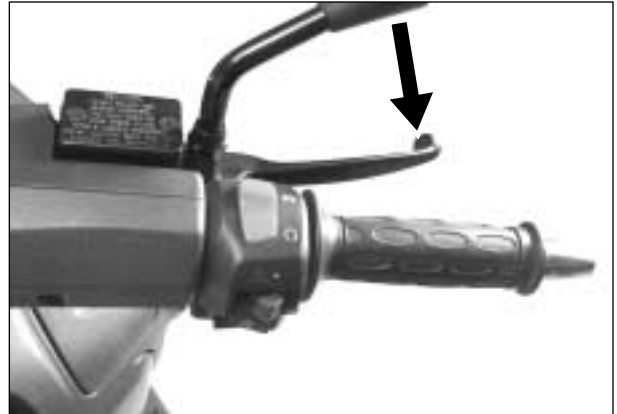

- Close the air bleeder valve and disconnect the transparent hose. Fill the reservoir with new brake fluid to the upper line.
- Replace the rear brake's fluid with the same manner of the front brake.

🔧 Front brake caliper air bleeder valve
: 9 ~ 14 N · m (0.9 ~ 1.4 kgf · m)

Rear brake caliper air bleeder valve
: 9 ~ 14 N · m (0.9 ~ 1.4 kgf · m)



🔧 AIR BLEEDING OF THE BRAKE FLUID CIRCUIT

Air trapped in the brake fluid circuit acts like a cushion to absorb a large proportion of the pressure developed by the master cylinder and thus interferes with the full braking performance of the brake caliper. The presence of air is indicated by "sponginess" of the brake lever and also by lack of braking force. Considering the danger to which such trapped air exposes the machine and rider, it is essential that, after remounting the brake and restoring the brake system to the normal condition, the brake fluid circuit be purged of air in the following manner :

- Fill the master cylinder reservoir to top of the inspection window. Replace the reservoir cap to prevent dirt from entering it.
- Attach a hose to the air bleeder valve, and insert the free end of the hose into a receptacle.
- Bleed air from the brake system.



2-21 PERIODIC MAINTENANCE

- Squeeze and release the brake lever several times in rapid succession and squeeze the lever fully without releasing it. Loosen the bleeder valve by turning it a quarter of a turn so that the brake fluid runs into the receptacle, this will remove the tension of the brake lever causing it to touch the handlebar grip. Then, close the air bleeder valve, pump and squeeze the brake lever, and open the valve. Repeat this process until the fluid flowing into the receptacle no longer contains air bubbles.

NOTE

While bleeding the brake system, replenish the brake fluid in the reservoir as necessary. Make sure that there is always some fluid visible in the reservoir.

- Close the air bleeder valve, and disconnect the hose.
Fill the reservoir with brake fluid to the upper line.
- Bleed the rear brake's air with the same manner of front brake.

 **Front brake caliper air bleeder valve**
: 9 ~ 14 N · m (0.9 ~ 1.4 kgf · m)

Rear brake caliper air bleeder valve
: 9 ~ 14 N · m (0.9 ~ 1.4 kgf · m)

CAUTION

Handle brake fluid with care : the fluid reacts chemically with paint, plastics, rubber materials, etc.

FRONT & REAR BRAKE LAMP SWITCH

The front & rear brake lamp switch is located beneath the front & rear brake lever. Loosen the switch fitting screws and adjust the timing by moving the switch body forward or backward.

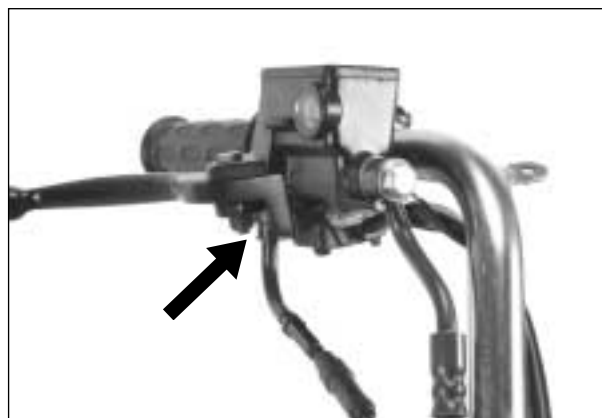
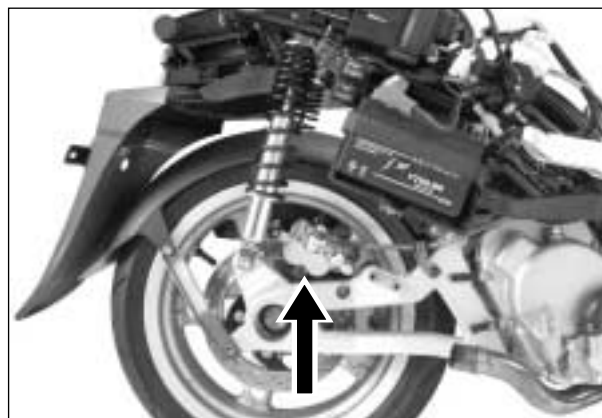
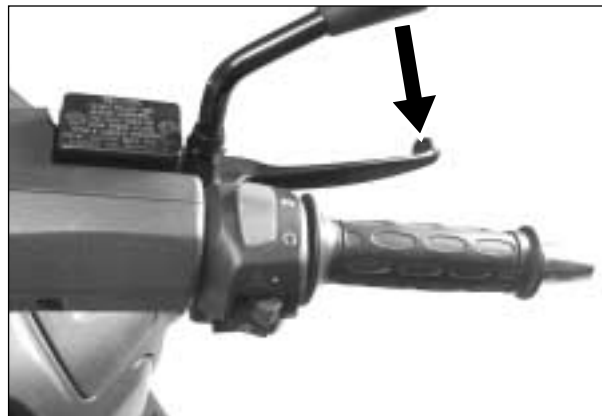

STEERING

Inspect Interval

Inspect Initial 1,000 km and Every 4,000 km thereafter.

Steering should be adjusted properly for smooth turning of handlebars and safe running. Overtight steering prevents smooth turning of the handlebars and too loose steering will cause poor stability. Check that there is no play in the steering stem while grasping the lower fork tubes by supporting the machine so that the front wheel is off the ground, with the wheel straight ahead, and pull forward. If play is found, perform steering stem nut adjustment as described in page 8-31 of this manual.



FRONT FORK

Inspect Interval

Inspect Every 4,000 km.

Inspect the front forks for oil leakage, scoring or scratches on the outer surface of the inner tubes. Replace any defective parts, if necessary.



REAR SHOCK ABSORBER

Inspect Interval

Inspect Every 4,000 km.

Inspect the rear shock absorber for oil leakage and mounting rubbers including engine mounting for wear and damage. Replace any defective parts, if necessary. (Refer to page 8-38)



TIRE

Inspect Interval

Inspect Initial 1,000 km and Every 4,000 km thereafter.

▣ TIRE TREAD CONDITION

Operating the motorcycle with excessively worn tires will decrease riding stability and can lead to loss of control.

- Inspect shortage of tire thread's depth by the 『tire wear indicator』.
- Replace the front and rear tires at once when appear the 『tire wear indicator』.

▣ TIRE PRESSURE

If the tire pressure is too high or too low, steering will be adversely affected and tire wear increased. Therefore, maintain the correct tire pressure for good enter key roadability or shorter tire life will result. Cold inflation tire pressure is as follows.

COLD INFLATION TIRE PRESSURE	SOLO RIDING			DUAL RIDING		
	kPa	kgf/cm ²	psi	kPa	kgf/cm ²	psi
Front	172	1.75	25.0	172	1.75	25.0
Rear	197	2.00	29.0	246	2.50	36.0

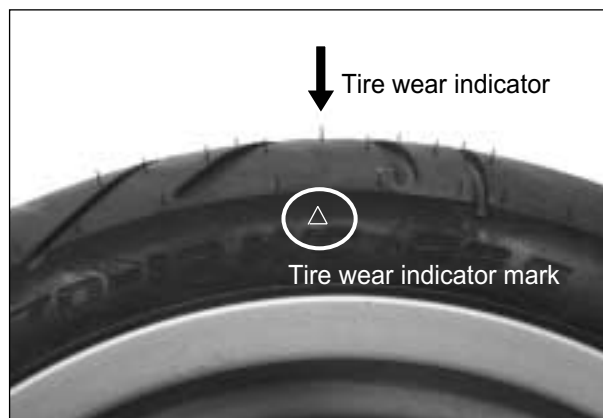

⚠ CAUTION

The standard tire on 『*MSA 650 / 659*』 are **120/70-13M/C 53S** for front and **140/60-14M/C 64S** for rear.
The use of tires other than those specified may cause instability. It is highly recommended to use a HYOSUNG Genuine Tire.

CHASSIS BOLTS AND NUTS

Inspect Interval

Inspect Initial 1,000 km and Every 4,000 km thereafter.

Check that all chassis bolts and nuts are tightened to their specified torque. (Refer to page 9-17)

COMPRESSION PRESSURE

The compression of a cylinder is a good indicator of its internal condition.

The decision to overhaul the cylinder is often based on the results of a compression test. Periodic maintenance records kept at your dealership should include compression reading for each maintenance service.



Compression pressure	
Standard	11 kgf/cm ² (at 500 rpm)
Service limit	10 kgf/cm ² (at 500 rpm)



Compression pressure	
Standard	15 kgf/cm ² (at 500 rpm)
Service limit	13 kgf/cm ² (at 500 rpm)

COMPRESSION TEST PROCEDURE

NOTE

- ❖ Before testing the engine for compression pressure, make sure that the cylinder head bolts are tightened to the specified torque values and valves are properly adjusted.
- ❖ Have the engine warmed up by idling before testing.
- ❖ Be sure that the battery used is in fully-charged condition.

Remove the related parts and test the compression pressure in the following manner.

- Support the motorcycle with the center stand.

⚠ WARNING

The hot engine can burn you. Wait until the engine are cool enough to touch.

- Using the side cover stay, lift the front end of the side cover and prop it up. (Refer to page 2-2)
- Remove the spark plug.
- Fit the compression gauge in the plug hole, while taking care that the connection is tightened.
- Keep the throttle grip in full-open position.
- Crank the engine a few seconds with the starter, and record the maximum gauge reading as the compression of cylinder.

Compression gauge : 09915-64511

Low compression pressure can indicate some of the following conditions :

- Excessively worn cylinder wall
- Worn-down piston or piston rings
- Piston rings stuck in grooves
- Poor seating of valves
- Ruptured or otherwise defective cylinder head gasket

NOTE

When the compression pressure goes below specification, check the engine for conditions listed above.



AUTOMATIC CLUTCH INSPECTION

- These motorcycles are equipped with an automatic clutch and variable ratio belt drive transmission. The engagement of the clutch is governed by engine RPMs and centrifugal mechanism located in the clutch.
- To insure proper performance and longer lifetime of the clutch assembly it is essential that the clutch engages smoothly and gradually. The following inspections must be performed :

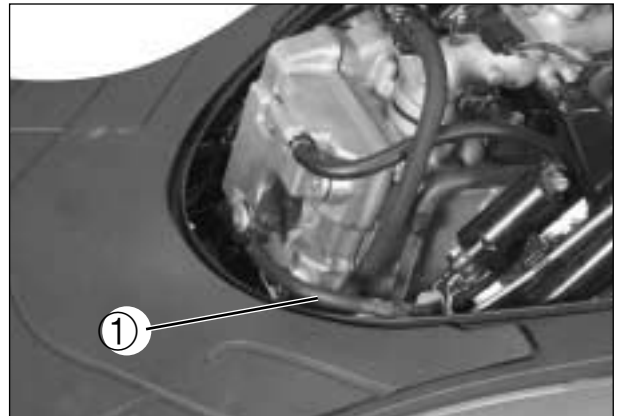

▣ INITIAL ENGAGEMENT INSPECTION

- Warm up the engine to normal operating temperature.
- Lift and support the side cover with the side cover stay. (Refer to page 2-2)
- Connect the engine tachometer to the high-tension cord ①.
- Seated on the motorcycle with the motorcycle on level ground, increase the engine RPMs slowly and note the RPM at which the motorcycle begins to move forward.

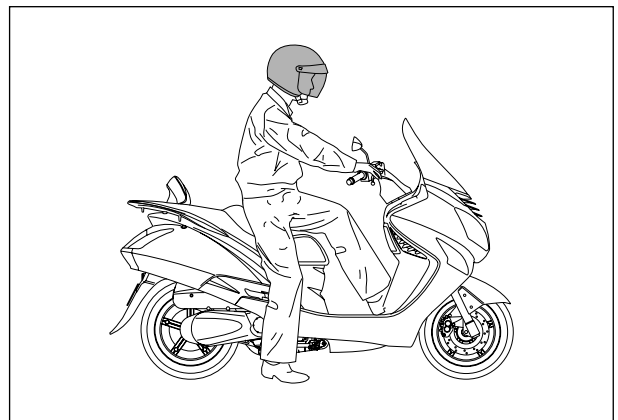

MSB 650

Engagement rpm	1,800 ~ 2,400 rpm
-----------------------	-------------------

MSB 125

Engagement rpm	3,600 ~ 4,200 rpm
-----------------------	-------------------

 **Engine tachometer : 09900-26006**

▣ CLUTCH “LOCK-UP” INSPECTION

- Perform this inspection to determine if the clutch is engaging fully and not slipping.
- Apply the front and rear brakes as firm as possible.
- Briefly open the throttle fully and note the maximum engine RPMs sustained during the test cycle.

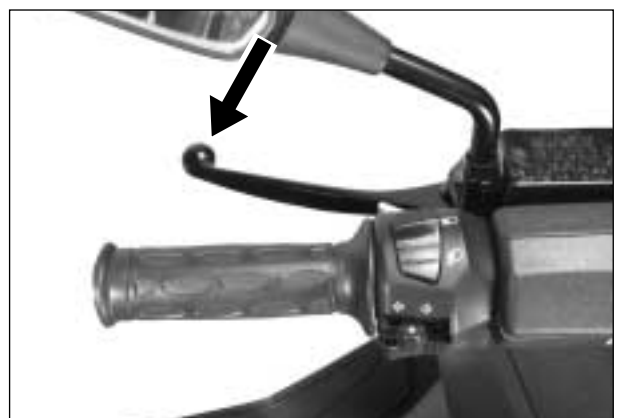
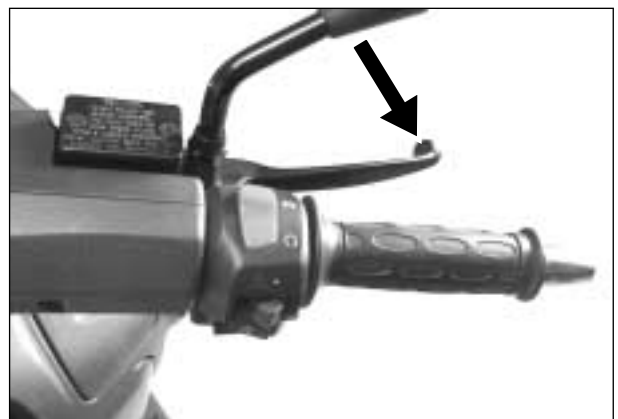

 **CAUTION**

Do not apply fully power for more than 3 seconds or damage to the clutch or engine may occur.

MSB 650

Lock-up rpm	2,300 ~ 2,900 rpm
--------------------	-------------------

MSB 125

Lock-up rpm	4,100 ~ 4,700 rpm
--------------------	-------------------

ENGINE

CONTENTS

ENGINE REMOVAL AND REMOUNTING	3- 1
ENGINE REMOVAL	3- 1
ENGINE REMOUNTING	3- 4
ENGINE DISASSEMBLY	3- 5
ENGINE COMPONENT INSPECTION AND SERVICE	3-16
CYLINDER HEAD	3-16
CYLINDER	3-23
CAM CHAIN TENSION ADJUSTER AND TENSIONER	3-24
PISTON AND PISTON RING	3-25
CONROD	3-28
CRANKSHAFT	3-29
CRANK BALANCER AND BALANCER DRIVEN GEAR (Only for 『 <i>MSA 350</i> 』)	3-30
MOVABLE DRIVE FACE	3-31
CLUTCH SHOE / MOVABLE DRIVEN FACE	3-31
BELT ROLLER (Only for 『<i>MSA 350</i>』)	3-35
CRANKCASE OIL SEAL, BEARING AND BUSHING	3-36
STARTER CLUTCH	3-36
ENGINE REASSEMBLY	3-37

CAUTION

- ❖ Mark an identification of assembly location on each removed part so that each will be restored to the original position during reassembly.
- ❖ Wash clean and dry the removed parts before inspecting and measuring.
- ❖ Oil the rotating or sliding parts before assembly.
- ❖ Make sure to use the correct type of lubricant where specified.
- ❖ Check that each rotating or sliding part moves or operates smoothly after assembly.
- ❖ Make sure to follow the bolt tightening order where specified.
- ❖ If the correct length of the bolt is confused when tightening the crankcase or cover, insert all the bolts and check that the tightening margin is equal in each bolt.

ENGINE REMOVAL AND REMOUNTING

ENGINE REMOVAL

- Remove the 『Seat, side cover & rear fender assembly』. (Refer to page 8-7)
- Drain the engine oil. (Refer to page 2-12)
- Remove the engine oil filter. (Refer to page 2-13)
- Drain the engine coolant. (Refer to page 2-16)
- Drain the transmission oil. (Refer to page 2-14)

- Disconnect the battery ⊖ lead wire ① .

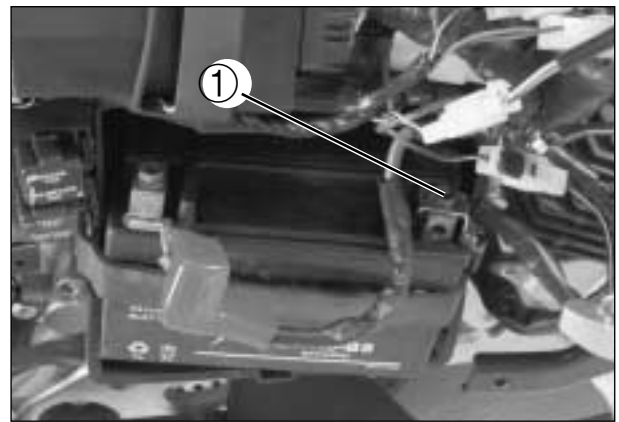

- Disconnect the breather hose ② .

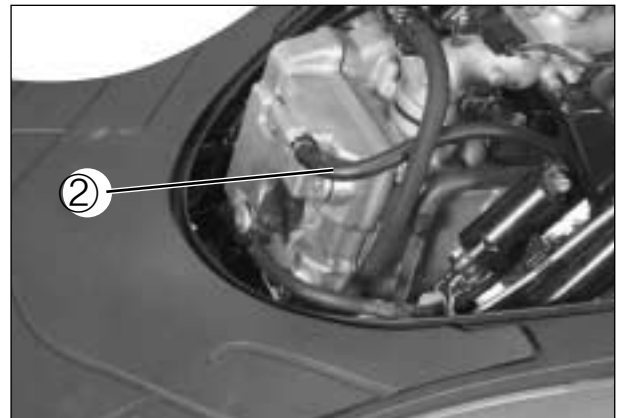

- Remove the all sensor coupler. (Refer to chapter 4 and 5)
- Disconnect the fuel injector hose ③ .

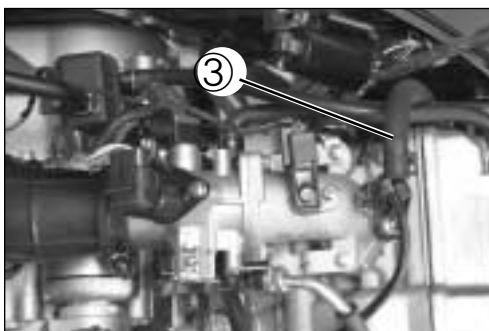

- Disconnect the ignition coil lead wires①.

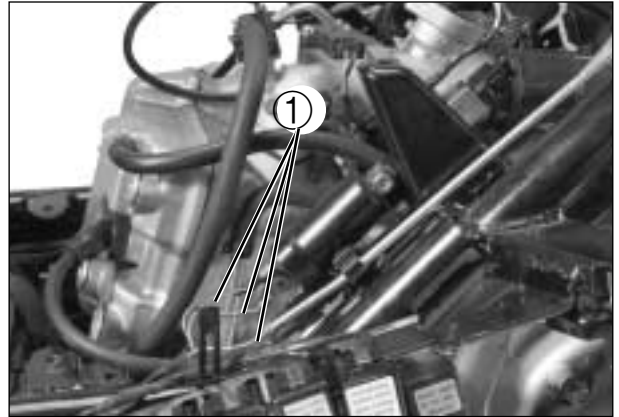

- Loosen the air cleaner hose clamp screw.
- Remove the air cleaner mounting bolts②.
- Remove the air cleaner box③.

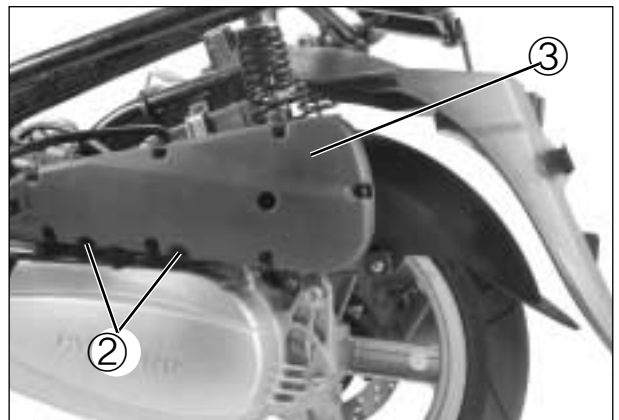

- Disconnect the starter motor lead wire④ and the engine ground lead wire⑤.

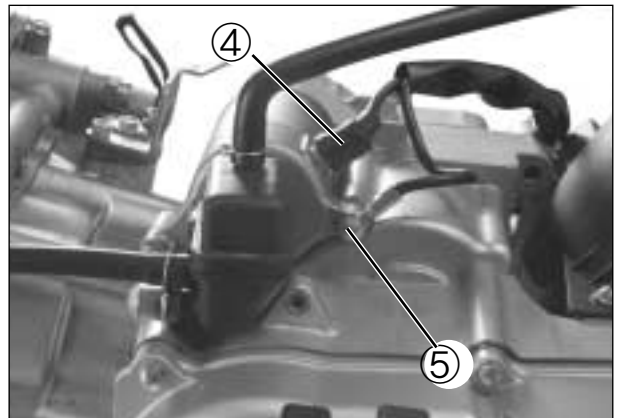

- Disconnect the magneto coupler⑥.



3-3 ENGINE

- Remove the water hoses ① and ②.

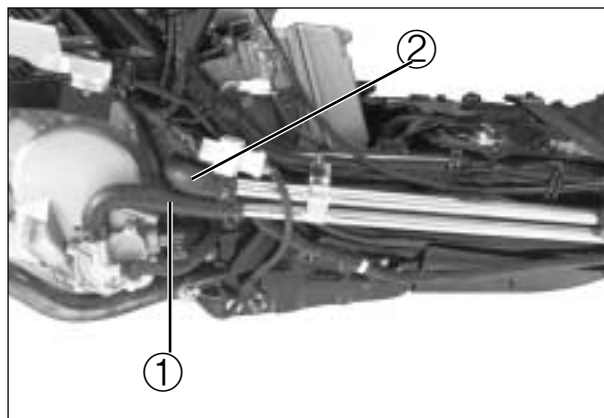

- Remove the exhaust pipe nuts ①.

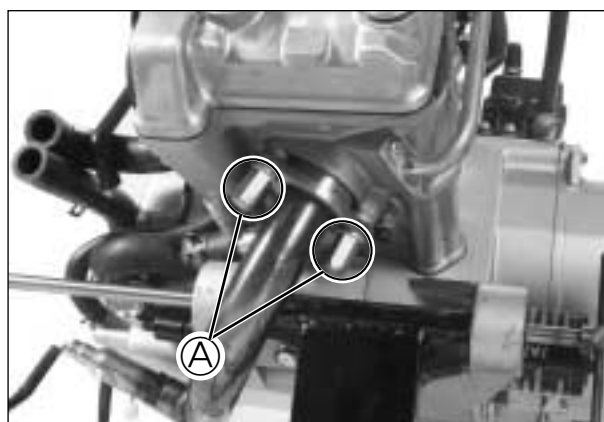

- Remove the muffler mounting bolts ②, ③.

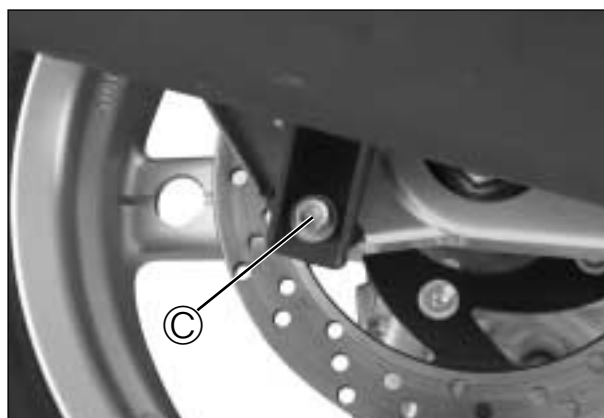
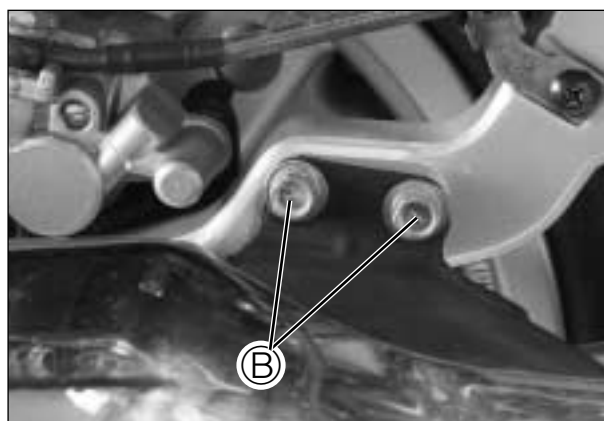
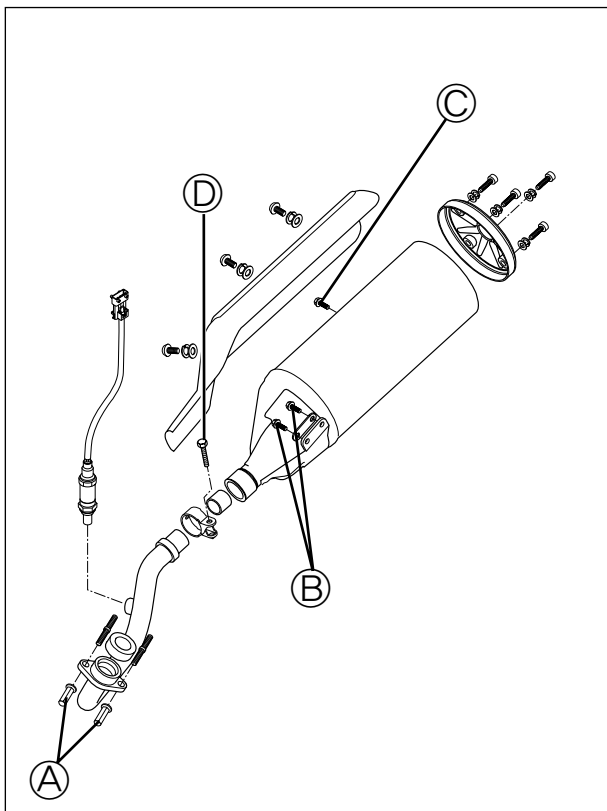

- Remove the muffler connecting bolt ①.

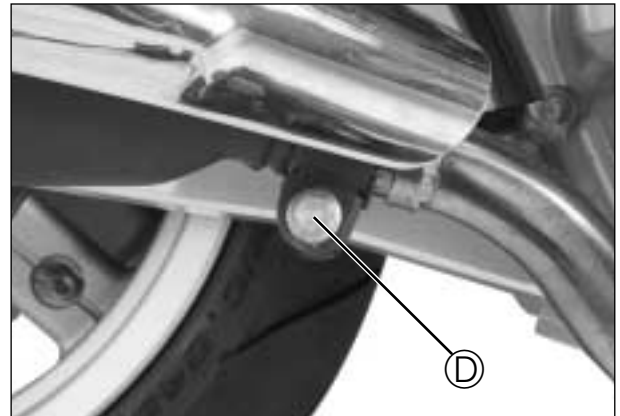

- Remove the rear brake caliper mounting bolts ②.
- Remove the rear brake hose union bolt ③.
- Remove the rear brake caliper ④.
- Loosen the rear shock absorber lower mounting bolt ⑤, right and left.
- Support the chassis with the center stand.

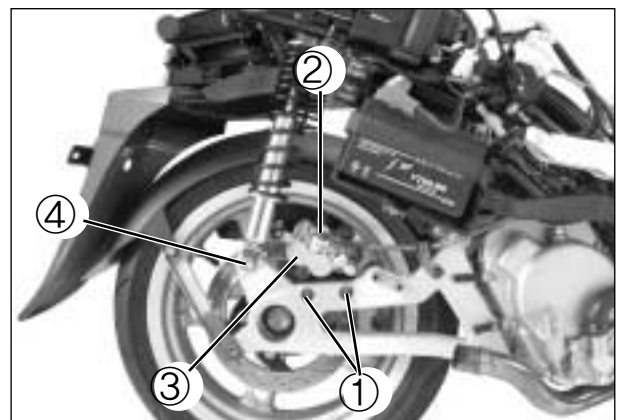

- Remove the engine mounting bolt and nut ⑥.
- Remove the engine from the frame.

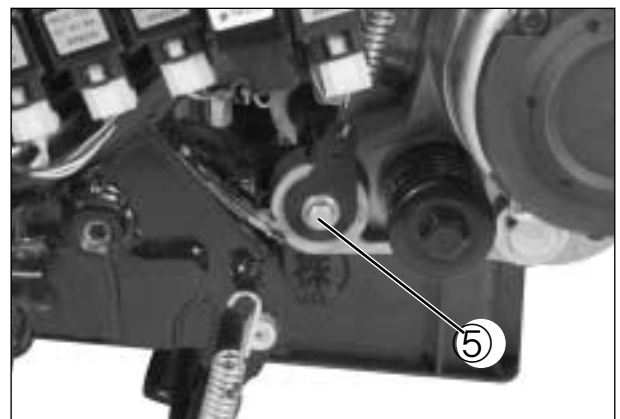

ENGINE REMOUNTING

Remount the engine in the reverse order of engine removal.

- Support the chassis with the center stand.
- Support the engine assembly with a proper engine jack.
- Tighten the engine mounting bolt ⑦ and rear shock absorber mounting bolt (right and left) ⑧ to the specified torque.

Engine mounting bolt

: 40 ~ 50 N · m (4.0 ~ 5.0 kgf · m)

Rear shock absorber mounting bolt

(Upper) : 40 ~ 50 N · m (4.0 ~ 5.0 kgf · m)

(Lower) : 25 ~ 35 N · m (2.5 ~ 3.5 kgf · m)

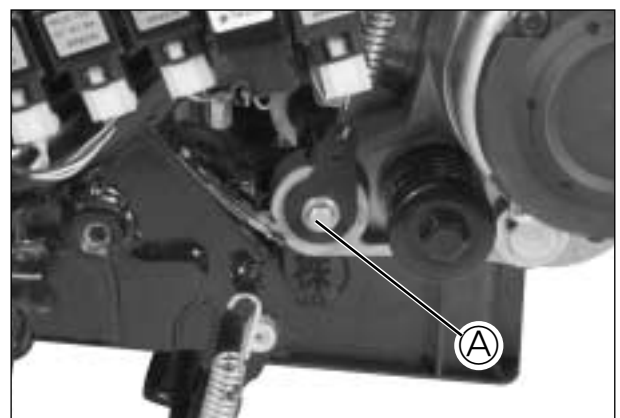

3-5 ENGINE

- After remounting the engine, route wiring harness, cables and hoses properly by referring to the sections, for wire routing, cable routing and hose routing. (See pages 9-31 through 36.)
- Pour the specified amount of transmission oil. (Refer to page 2-14)
- Pour the specified amount of engine coolant. (Refer to page 2-16)
- Pour the specified amount of engine oil. (Refer to page 2-12)

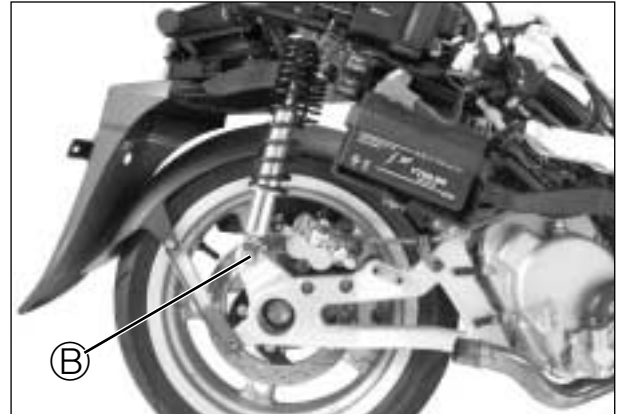

- Adjust the following items to the specification.
 - * Throttle cable play Refer to page 2-11
 - * Idling inspect Refer to page 2-11
- Check for leakage of the engine oil, transmission oil and engine coolant.

ENGINE DISASSEMBLY

⚠ CAUTION

- ❖ Put the removed parts from the engine in order in each component part.
- ❖ Be careful not to cause damage on the removed parts when handling.

- Remove the intake pipe bolts and then remove the intake pipe ① together with the throttle body ② .

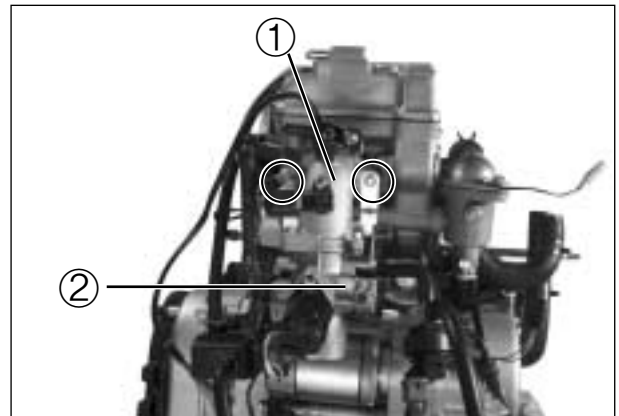

- Remove the insulator ③ and O-ring.

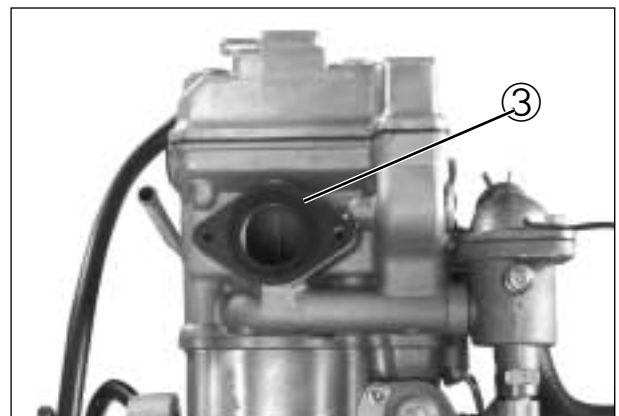

- Remove the starter motor ① and the oil return tank ②.

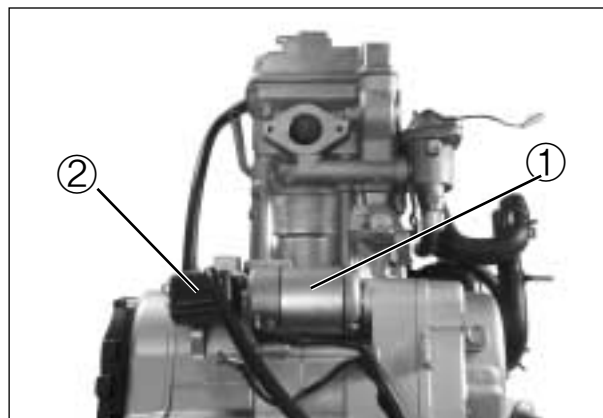

- Remove the clutch cover ③.
- Remove the gasket and dowel pins.

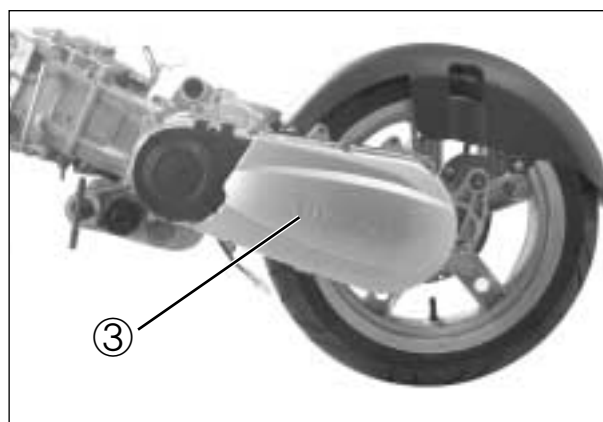

- Loosen the fixed drive face nut ④ and clutch housing nut ⑤.
- Remove fixed drive face ⑥ and clutch housing ⑦.

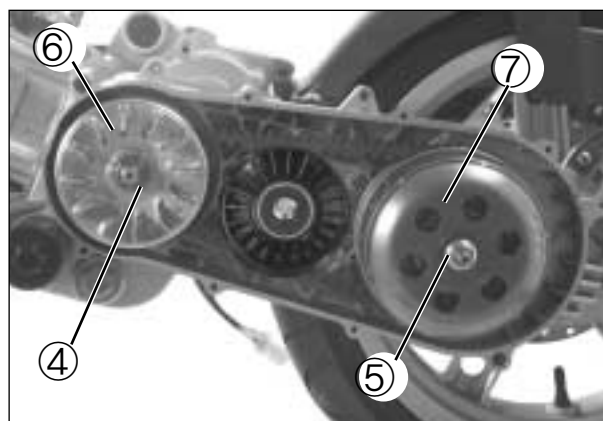

- Remove the movable drive face assembly ⑧ with the spacer ⑨.

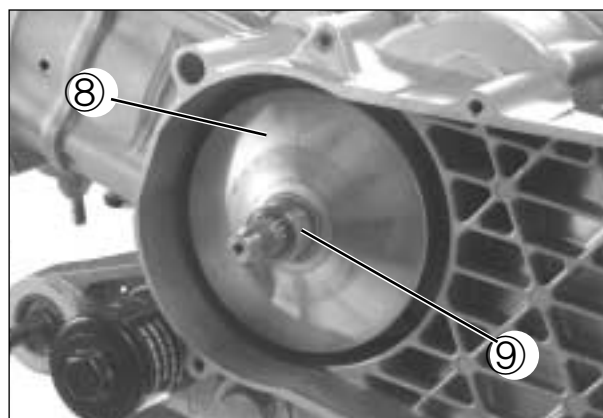

3-7 ENGINE

- Remove the belt roller① . (only for 『MSA 330』)

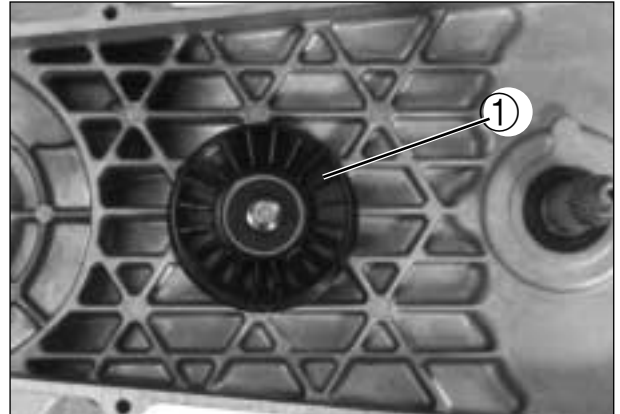

- Remove the thermostat case② .

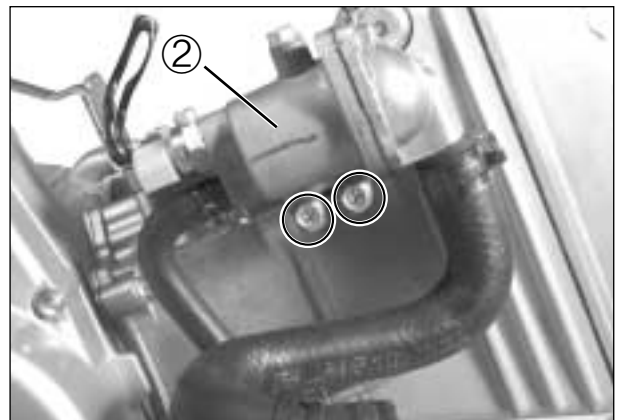

- Remove the four water pump case mounting bolts, and then remove the water pump case③ .

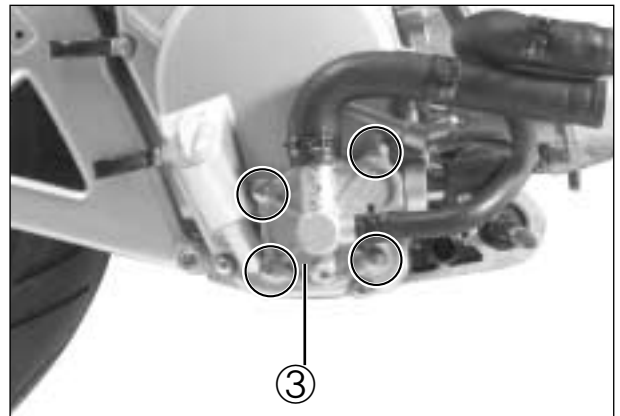

- Remove the magneto cover④ .

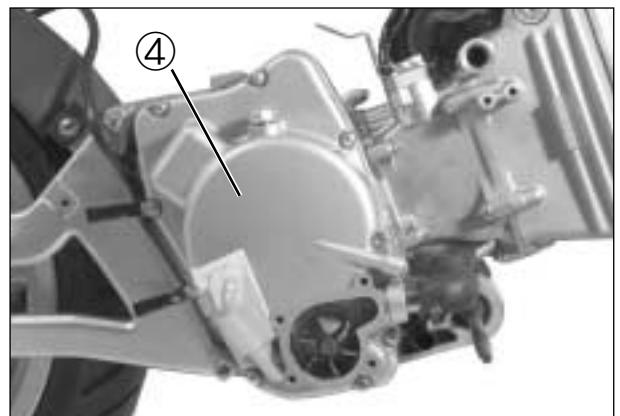

- Remove the starter idle gear shaft and the starter idle gear ①.

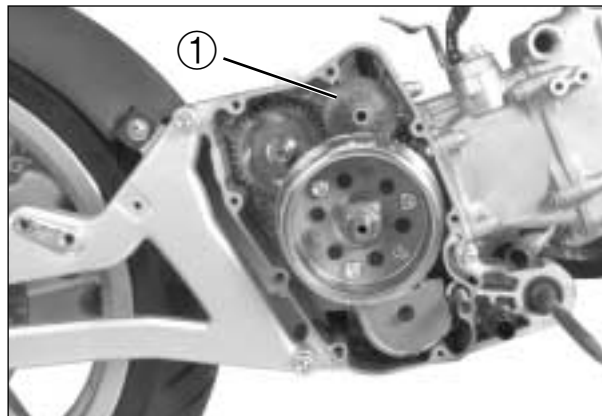

- Loosen the magneto rotor nut.



- Remove the magneto rotor ② by using the special tool.

 **Rotor remover sliding shaft**
: 09930-30102
Rotor remover : 09930-30162

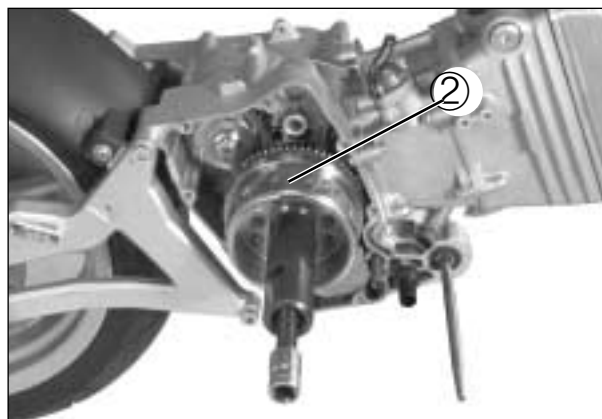

- Remove the key ③ and starter clutch gear ④.

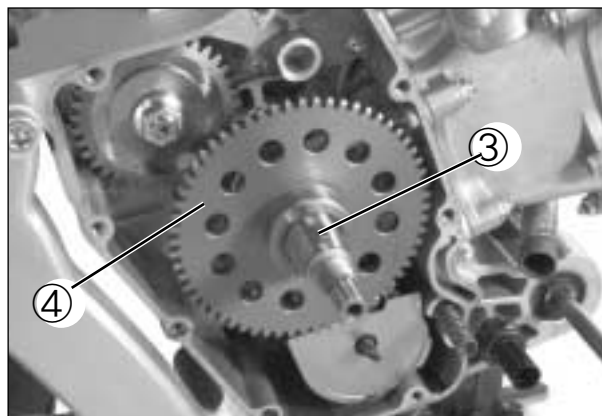

3-9 ENGINE

- Remove the oil pump cover mounting bolt, and then remove the oil pump cover①.

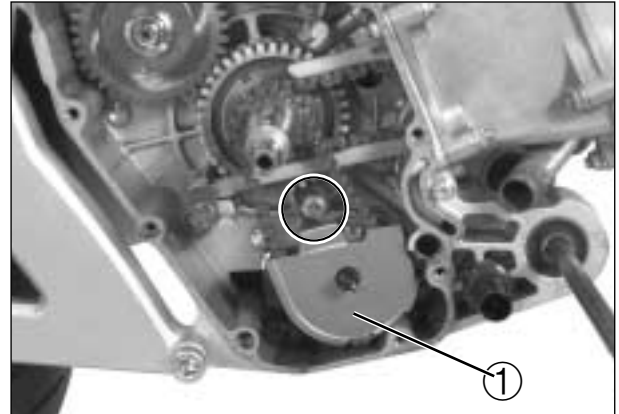

- Remove the oil pump sprocket circlip②, oil pump chain③ and oil pump sprocket④.

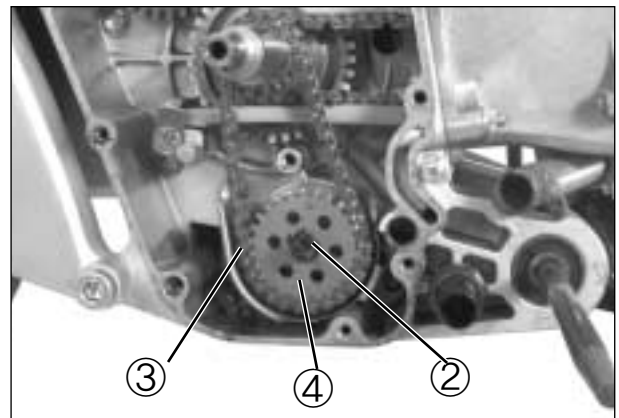

- Remove the oil pump chain guide⑤ and oil pump⑥.

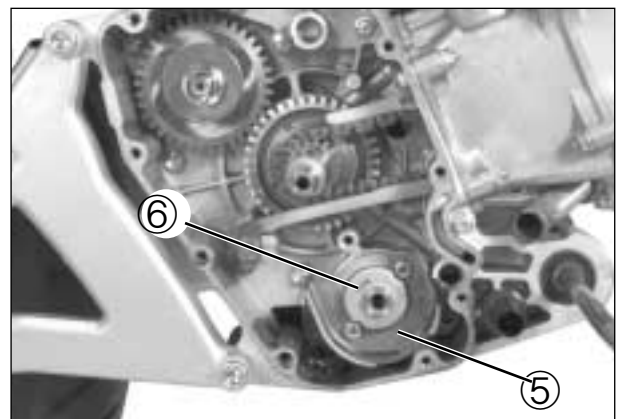

- Remove the crank balancer driven gear nut⑦.
(Only for 『MSA 350』)

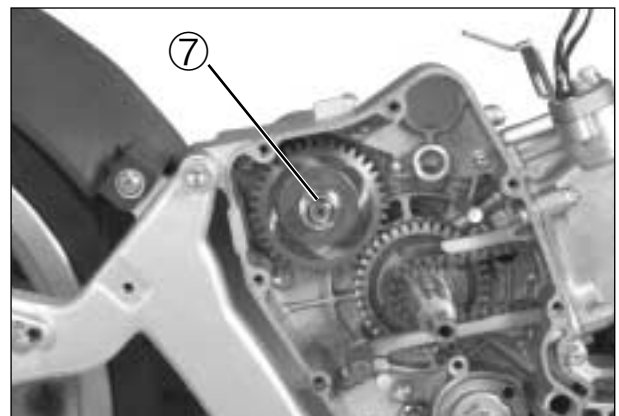

- Remove the three front rear fender mounting bolts, and then remove the front rear fender①.

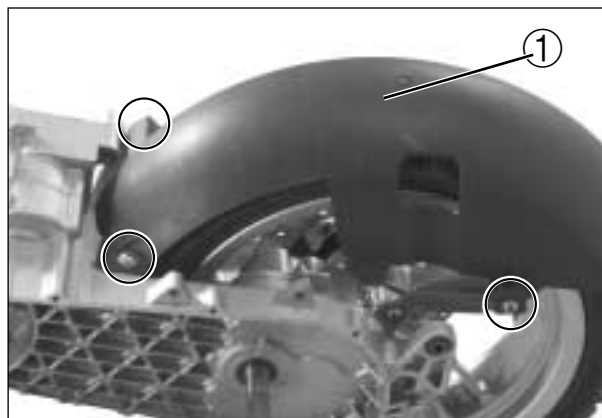

- Remove the rear suspension arm②.
- Remove the rear axle nut③.

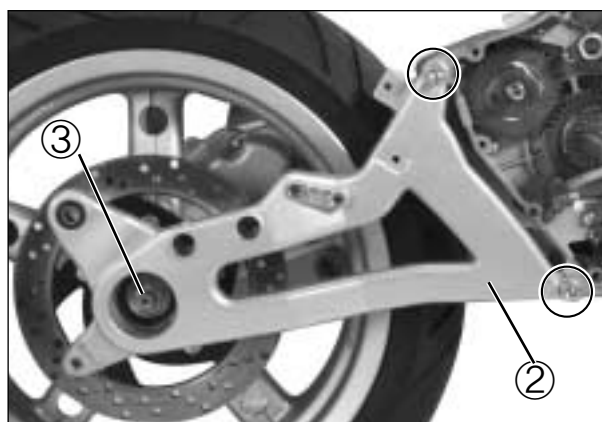

- Remove the cam chain tension adjuster bolt④.

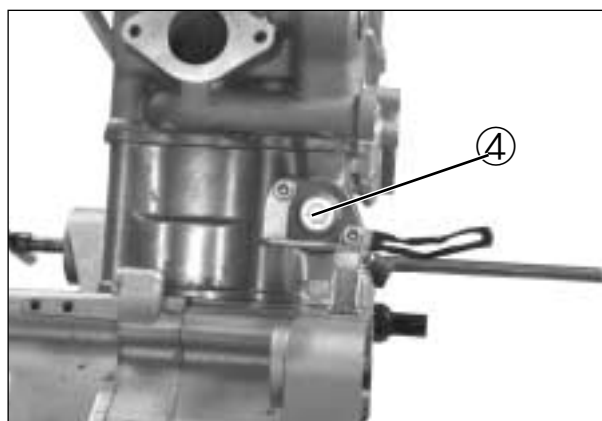

- Remove the cam chain tension adjuster⑤.

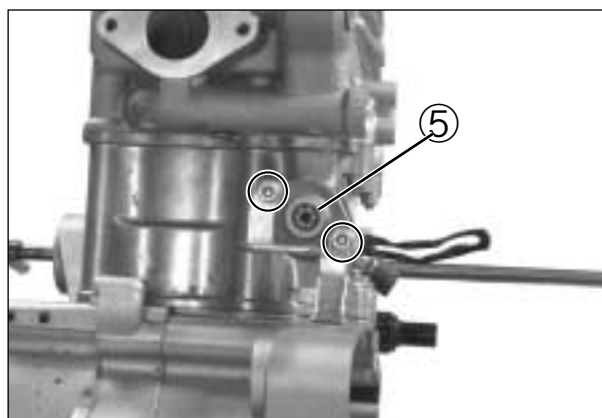

3-11 ENGINE

- Remove the cylinder head cover bolts in diagonal stages, and then remove the cylinder head cover ①.

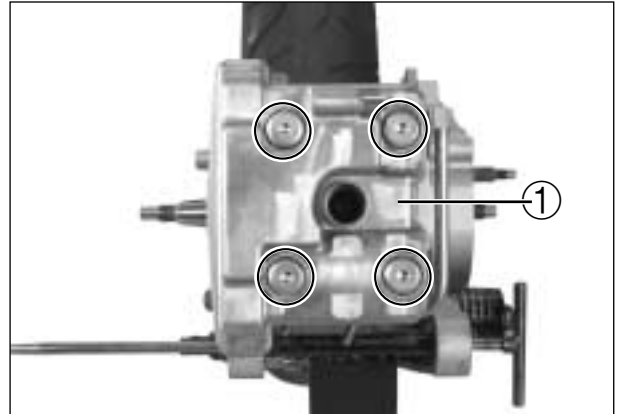

- Remove the cam chain guide ② and camshaft housing ③.

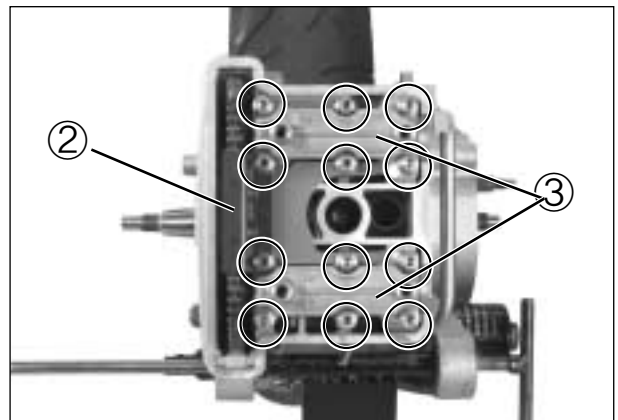

- Remove the dowel pins, intake camshaft ④ and exhaust camshaft ⑤.

NOTE

Do not drop the dowel pins and camshaft drive chain into the crankcase.

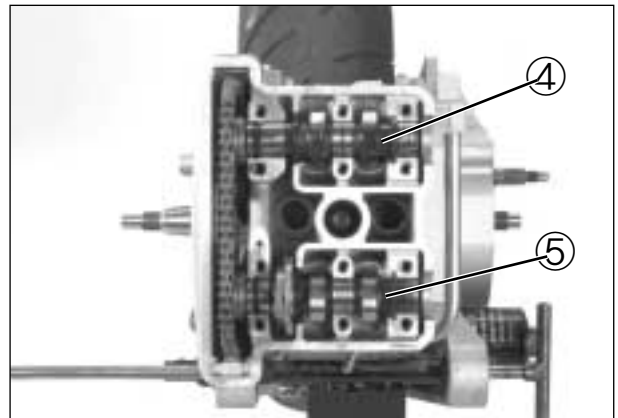

- Remove the three cylinder head base nuts.



3-12 ENGINE

- Remove the four cylinder head bolts in diagonal stages.

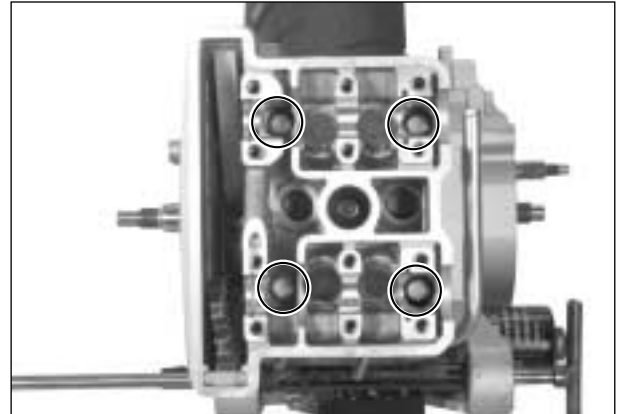

- Remove the cam chain guide ①.
- Remove the cylinder head ②.

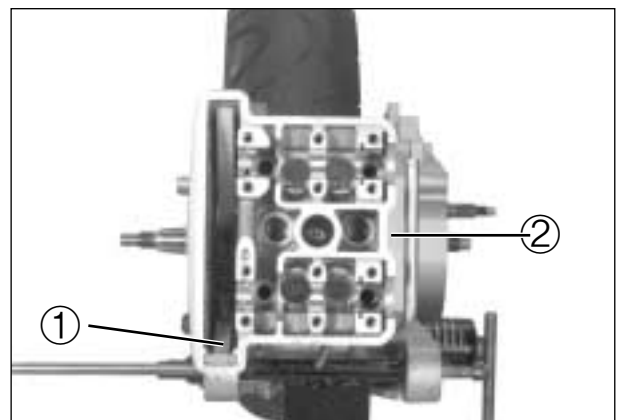

- Remove the cylinder head gasket ③ and dowel pins ④.

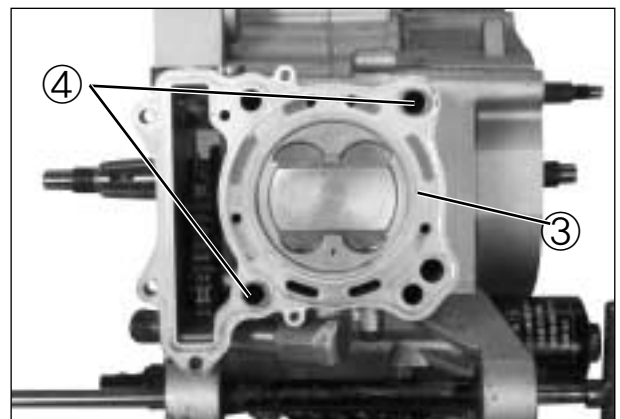

- Remove the two cylinder base nuts ⑤, and then remove the cylinder ⑥.

NOTE

If the cylinder does not come off easily, lightly tap it using a plastic hammer.

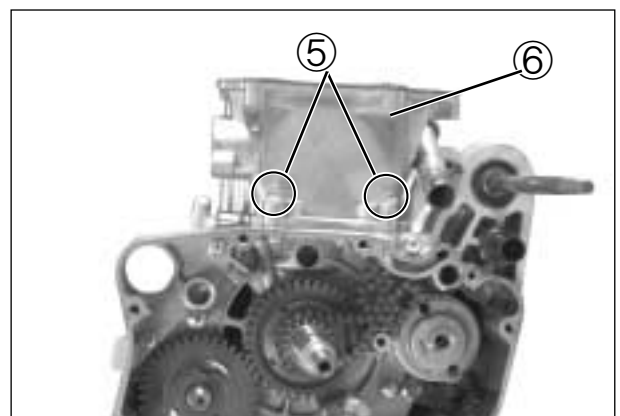

3-13 ENGINE

- Remove the cylinder gasket① and dowel pins②.

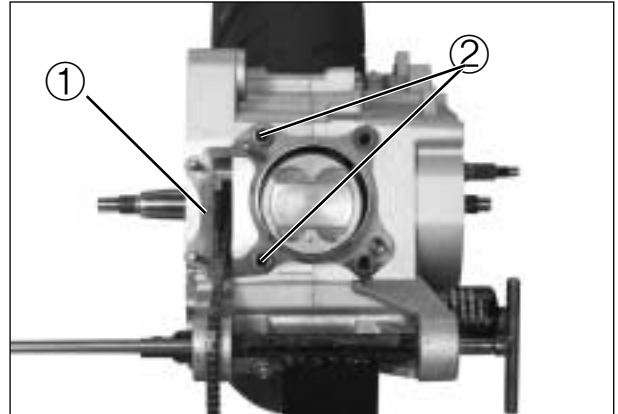

- Place a clean rag over the cylinder base to prevent the piston pin circlip from dropping into the crankcase.
- Remove the piston pin circlip.
- Draw out the piston pin and remove the piston.

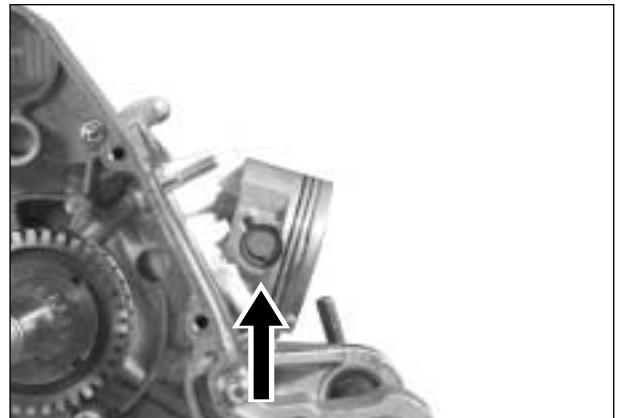

- Hold the crankshaft immovable using the special tool.

 **Conrod holder : 09910-20115**

- Loosen the crank balancer drive nut ③ using the special tool.

 **Crank balancer socket wrench : 09940HP7600**

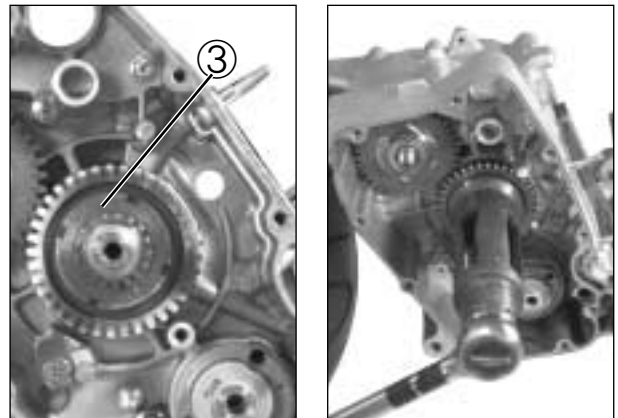

- Remove the crank balancer drive gear④.
 - Remove the crank balancer driven No.2 gear⑤ and the crank balancer driven No.1 gear⑥.
- (Only for 『MSB 250』)

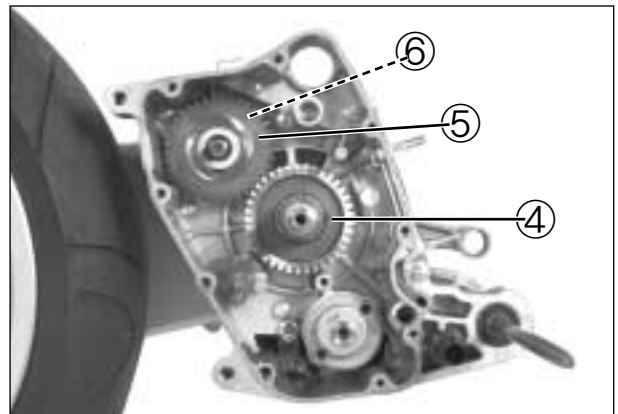

- Remove the rear axle spacer ①, and then remove the rear wheel ②.

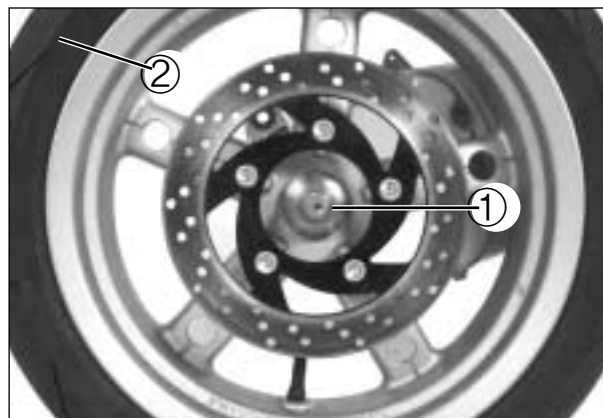

- Remove the rear axle shaft ③ together with the gear box cover ④.

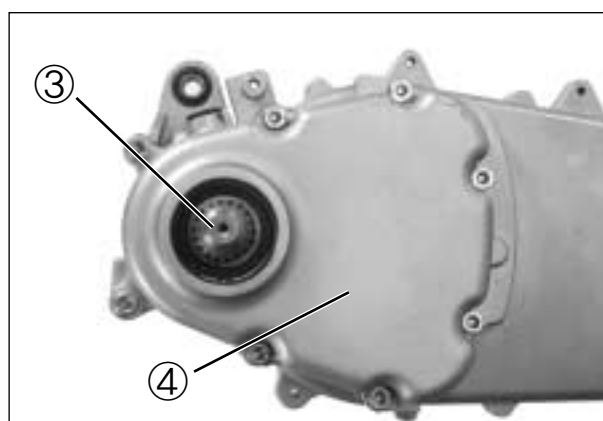

- Remove the idle shaft ⑤, idle driven gear ⑥ and drive shaft ⑦.

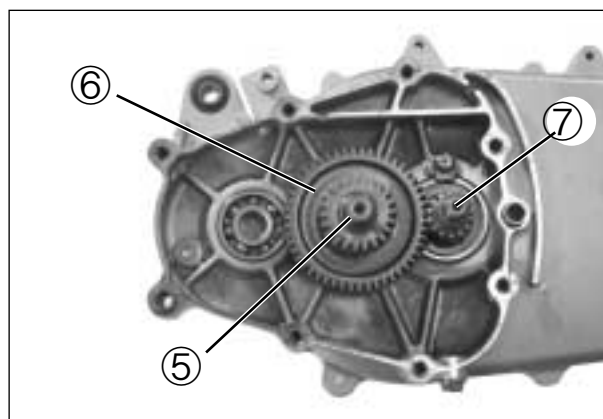

- Remove the circlip ⑧.
- Remove the rear axle shaft ⑨ and final driven gear ⑩ from the gear box cover.

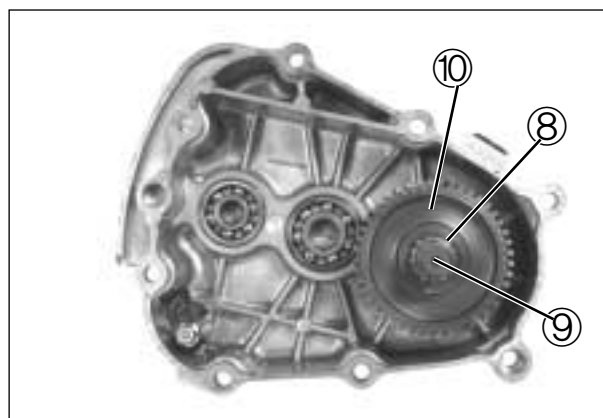

3-15 ENGINE

- Remove the crankcase bolt.

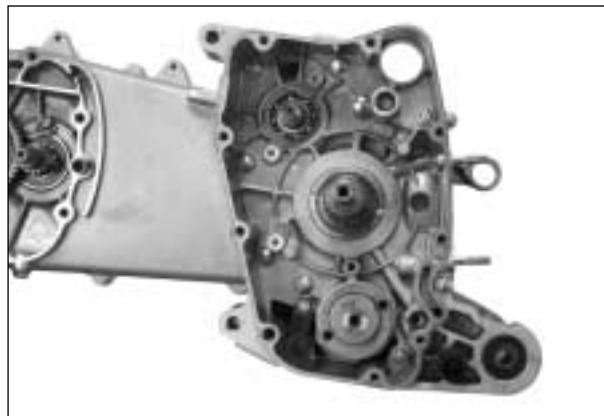

- Separate the crankcase into left and right halves using the special tool.

 **Crankcase separator : 09920-13120**

NOTE

The crankcase separator plate is parallel with the end face of the crankcase.



CAUTION

The crankshaft must remain in the left crankcase half.



- Remove the crank balancer①.
(Only for 『MSB 850』)

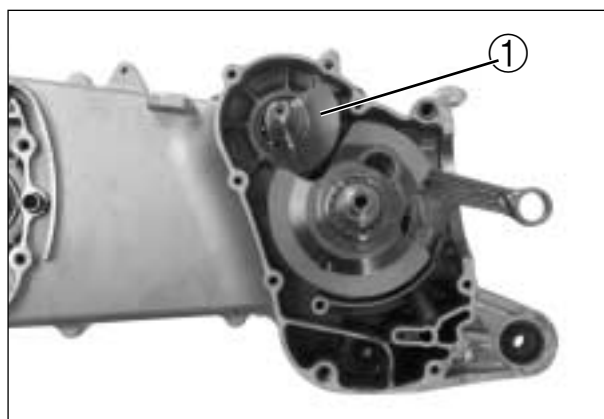

- Remove the crankshaft② from the crankcase.



- Remove the jet ①.

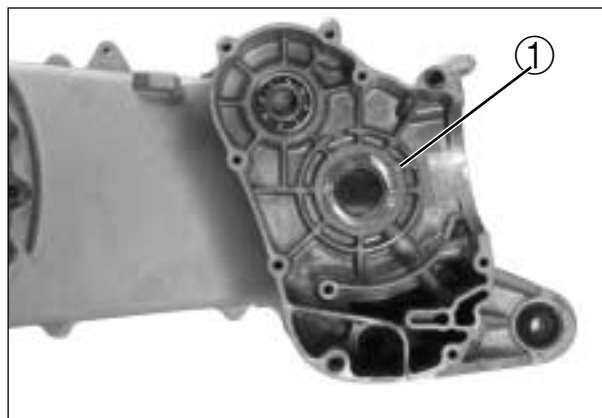

ENGINE COMPONENT INSPECTION AND SERVICE

CAUTION

Identify the position of each removed part. Organize the parts in their respective group (for example, exhaust or intake) so that they can be installed in their original positions.

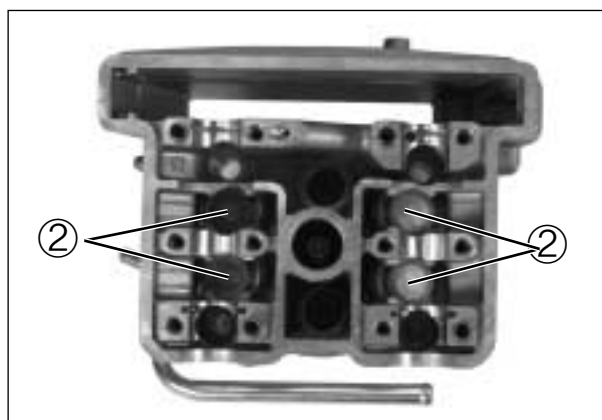

CYLINDER HEAD

DISASSEMBLY

- Remove the tappets ② and shims ③ by hand or by using a magnet.

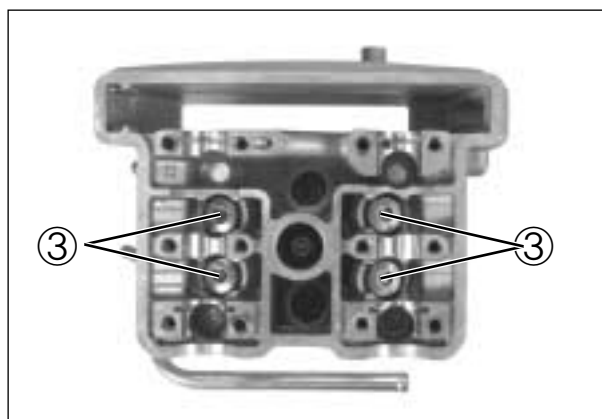

- Compress the valve springs, and then remove the valve cotters from the valve stem using the special tools.

 Valve spring compressor

: 09916-14510

Valve spring compressor attachment

: 09916H35C00 (*MSB* )

Valve spring compressor attachment

: 09916HG5100 (*MSB* )



3-17 ENGINE

- Remove the valve spring retainer ①, valve spring ②.
- Remove the valve ③ from the other side.
- Remove the oil seal ④ with long-nose pliers.
- Remove the valve spring seat ⑤.

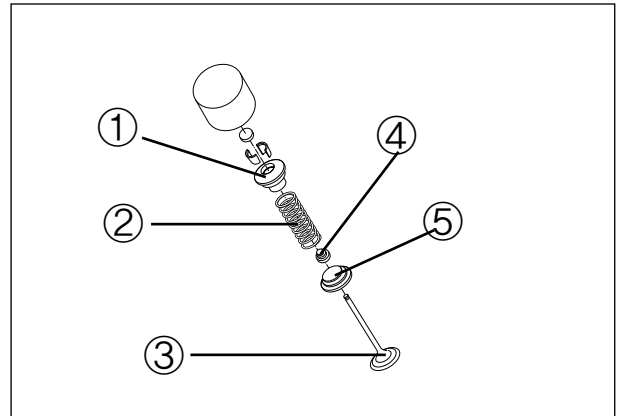

▣ REASSEMBLY

- Install each valve spring seat ⑤.
- Apply **MOLY PASTE** to each oil seal and press-fit them into position.

 **MOLY PASTE**

CAUTION

Do not reuse the oil seals.

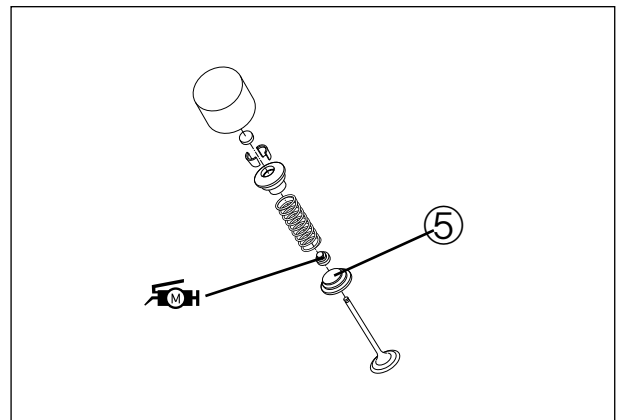

- Apply **MOLY PASTE** to the valve as shown, and then insert them into the valve guides.

 **MOLY PASTE**

CAUTION

When inserting each valve into the valve guides, make sure not to damage the lip of the oil seal.

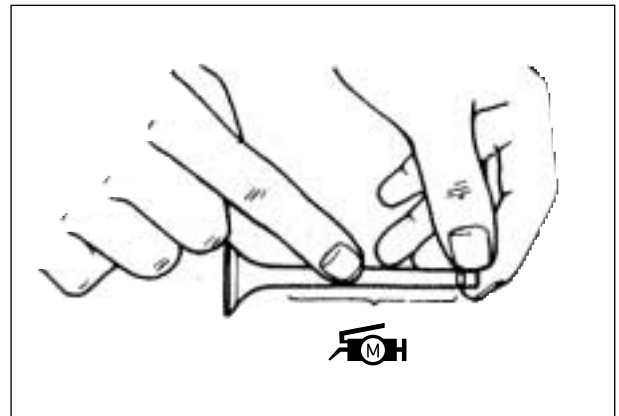

- Install the valve spring with the smaller pitch (A) facing the cylinder head.

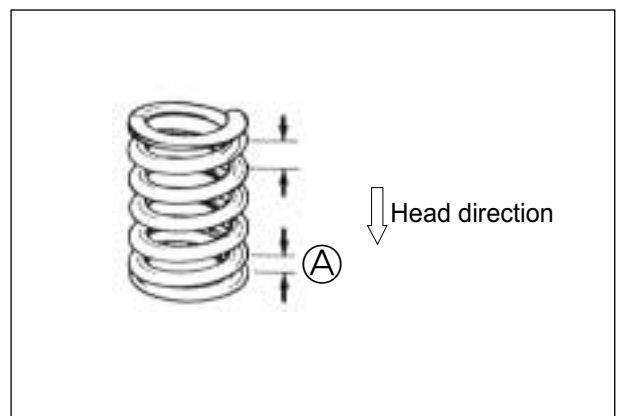

- Install the valve spring retainer by pressing down the spring using the valve spring compressor. Fit the cotter halves to the stem end and release the lifter to allow the cotter ① to wedge between the retainer and the valve stem. Make sure that the rounded lip ② of the cotter fits snugly into the groove ③ in the stem end.

-  **Valve spring compressor**
: 09916-14510
- Valve spring compressor attachment**
: 09916H35C00 (*MSB* *ESD*)
- Valve spring compressor attachment**
: 09916HG5100 (*MSB* *ES*)

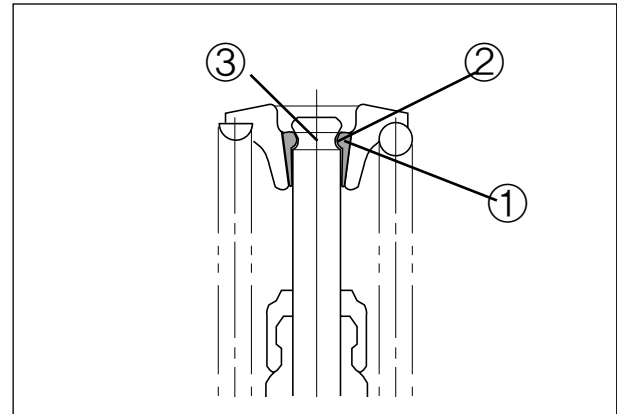

 **CAUTION**

Be sure to install all of the parts in their original positions.

 **CYLINDER HEAD DISTORTION**

Decarbonize in combustion chamber.
Check the gasket surface of the cylinder head for distortion using a straightedge and thickness gauge. Take clearance reading at several places as indicated.
If any clearance reading exceeds the service limit, replace the cylinder head with a new one.

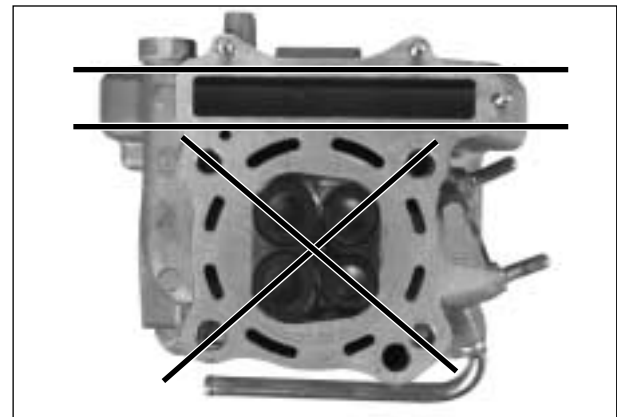

Cylinder head distortion	Service limit
	0.05 mm (0.002 in)

-  **Thickness gauge** : 09900-20806

 **VALVE FACE WEAR**

Visually inspect each valve face for wear or damage. If any abnormal wear is found, replace the respective valve with a new one. The thickness of the valve face decreases as the face wears. Measure the valve head thickness ①. If the valve head thickness is not within the specified value, replace the valve with a new one.

Valve head thickness ① (IN. & EX.)	Service limit
	0.5 mm (0.02 in)

-  **Vernier calipers** : 09900-20101

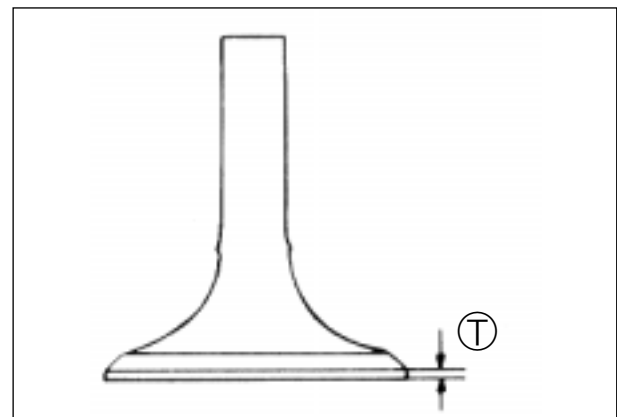

▣ VALVE STEM RUNOUT

Check the valve stem for abnormal wear or bend. Support the valve using a V-blocks and measure the valve stem runout using the dial gauge, as shown. If the service limit is exceeded or abnormal condition exists, replace the valve with a new one.

Valve stem runout (IN. & EX.)	Service limit
	0.05 mm (0.002 in)

-  Dial gauge : 09900-20606
- Magnetic stand : 09900-20701
- V-block : 09900-21304



▣ TAPPET & SHIM WEAR

When measuring the valve clearance, the clearance should be within the standard range.

Valve clearance	Standard (When cold)
Intake valve	0.1 ~ 0.2 mm (0.004 ~ 0.008 in)
Exhaust valve	0.2 ~ 0.3 mm (0.008 ~ 0.012 in)

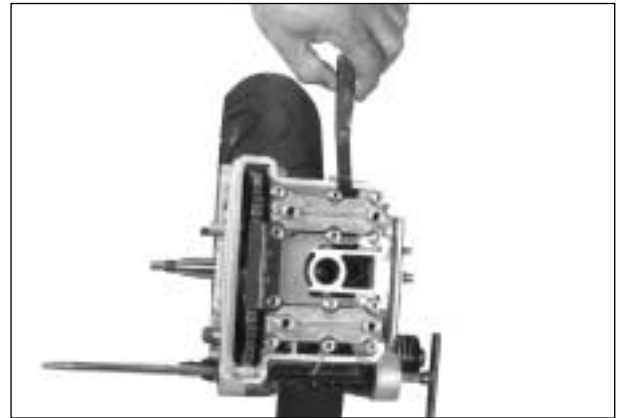

- Inspect the tappet for wear and scratch. If modification or scratch is present, replace the tappet.
- When you checked the valve clearance, if the valve clearance is wide please replace the present shim into thick one, if the valve clearance is narrow please replace the present shim into thin shim. (Refer to page 9-37 · 38)

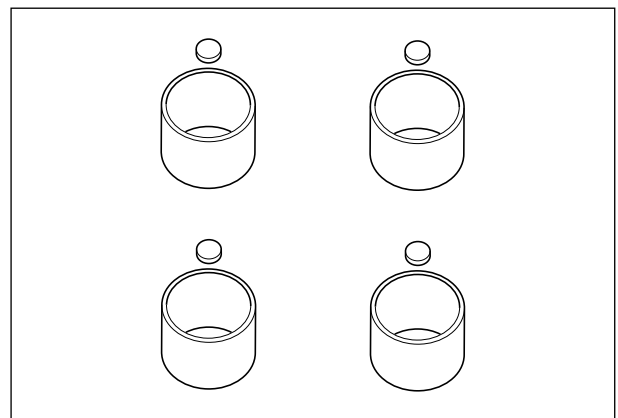

▣ SHIM KIND

There are 41 kinds of shim which thickness is increased by each 0.025 mm from 1.20 mm to 2.20 mm.

▣ VALVE HEAD RADIAL RUNOUT

Support the valve using a V-block and measure the valve head radial runout using the dial gauge, as shown. If the runout exceeds the service limit, replace the valve with a new one.

Valve head radial runout (IN. & EX.)	Service limit
	0.03 mm (0.0012 in)

 Dial gauge : 09900-20606
Magnetic stand : 09900-20701
V-block : 09900-21304

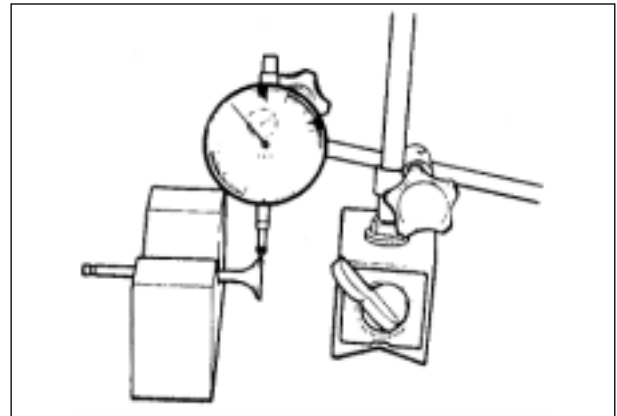

▣ VALVE STEM DEFLECTION

Lift the valve about 10 mm (0.39 in) from the valve seat. Measure the valve stem deflection in two directions, "X" and "Y", perpendicular to each other. Position the dial gauge as shown.

If the deflection exceeds the service limit, determine whether the valve or the guide should be replaced with a new one.

Valve stem deflection	Service limit
IN.	0.35 mm (0.014 in)
EX.	0.35 mm (0.014 in)

 Dial gauge : 09900-20606
Magnetic stand : 09900-20701

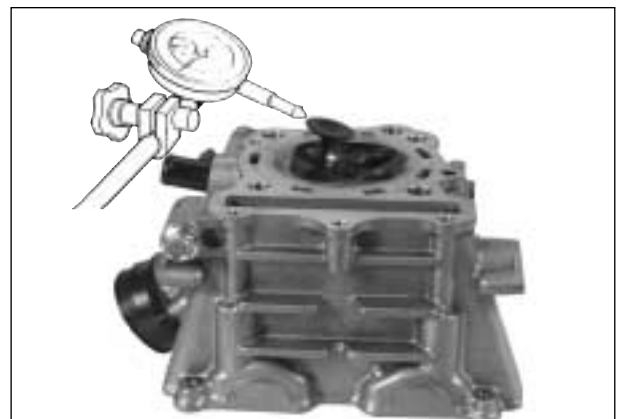

▣ VALVE STEM DIAMETER

Measure the valve stem outside diameter using the micrometer.

If the diameter measured exceeds the standard, replace the valve.

Valve stem diameter	Standard	
	<i>MSB 250</i>	<i>MSB 125</i>
IN.	4.465 ~ 4.480 mm (0.1758 ~ 0.1764 in)	4.475 ~ 4.490 mm (0.1762 ~ 0.1768 in)
EX.	4.455 ~ 4.470 mm (0.1754 ~ 0.1760 in)	4.455 ~ 4.470 mm (0.1754 ~ 0.1760 in)

 Micrometer(0~25 mm) : 09900-20201

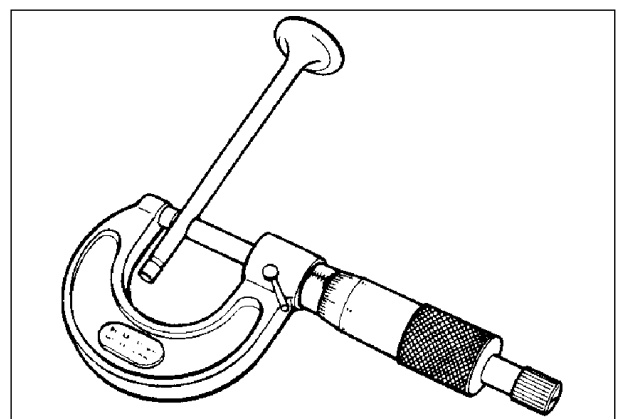

▣ VALVE SPRING

The force of the coil spring keeps the valve seat tight. A weakened spring results in reduced engine power output and often accounts for the chattering noise coming from the valve mechanism.

Check the valve springs for proper strength by measuring their free length and also by the force required to compress them. If the spring length is less than the service limit or if the force required to compress the valve spring is not within specification, replace the valve spring.

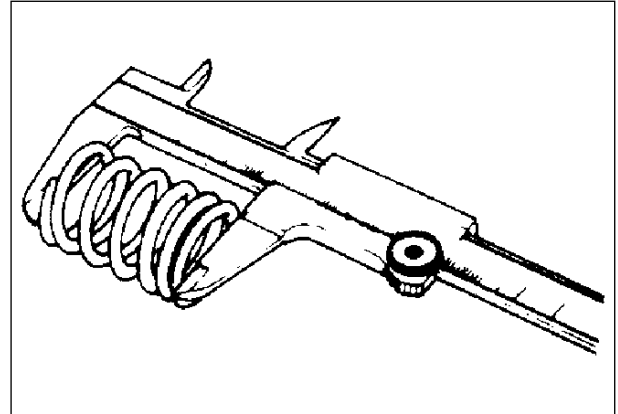

Valve spring free length (IN. & EX.)	Service limit	
	<i>MSB 250</i>	<i>MSB 125</i>
	40.67 mm (1.601 in)	39.35 mm (1.549 in)

 Vernier calipers : 09900-20101

Valve spring tension (IN. & EX.)	Standard	
	<i>MSB 250</i>	<i>MSB 125</i>
	18.50 ~ 21.50 kgf (40.79 ~ 47.40 lbs) at length 31.8 mm (1.25 in)	12.35 ~ 13.65 kgf (27.23 ~ 30.09 lbs) at length 33.7 mm (1.33 in)

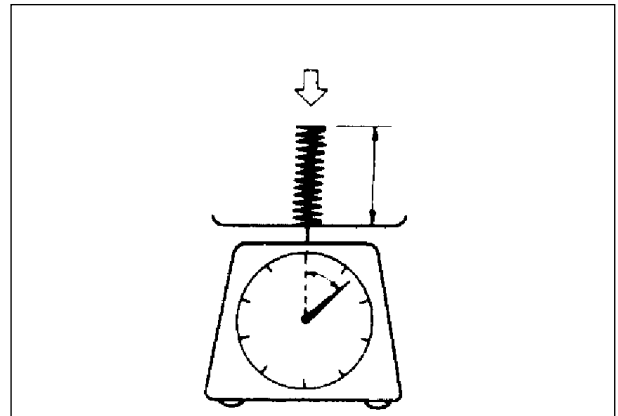

▣ CAMSHAFT

The camshaft should be checked for runout and also for wear of cams and journals if the engine has been noted to produce abnormal noise or vibration or a lack of out-put power. Any of these abnormality could be caused by a worn camshaft.

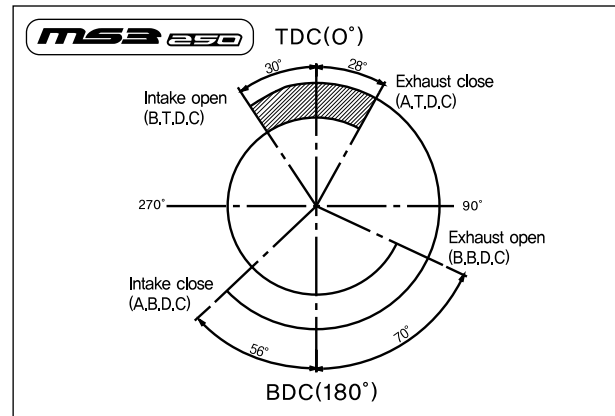

▣ CAMSHAFT WEAR

Worn-down cams are often the cause of mistimed valve operation resulting in reduced output power. The limit of cam wear is specified for both intake and exhaust cams in terms of cam height (H), which is to be measured with a micrometer. Replace camshafts if found it worn down to the limit.

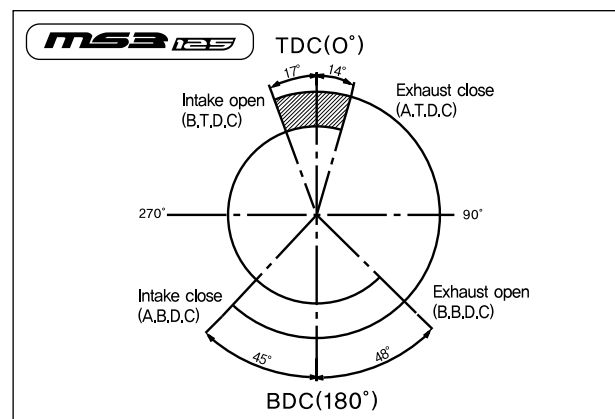

MSB 250	
Cam height (H)	Service limit
Intake cam	32.72 mm (1.288 in)
Exhaust cam	32.52 mm (1.280 in)

MSB 129	
Cam height (H)	Service limit
Intake cam	34.17 mm (1.345 in)
Exhaust cam	34.12 mm (1.343 in)

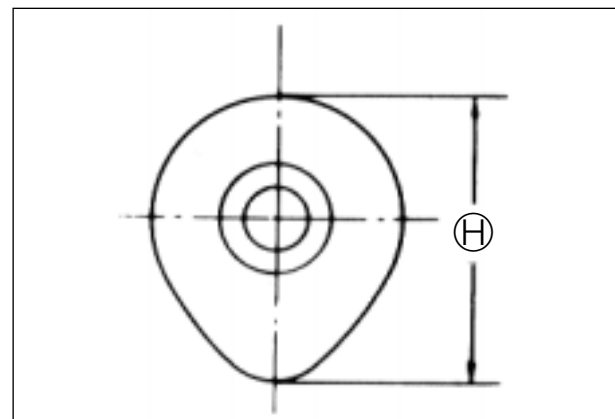

TOOL Micrometer(25~50 mm) : 09900-20202

▣ CAMSHAFT JOURNAL WEAR

Determine whether or not each journal is worn down to the limit by measuring the oil clearance with the camshaft installed in place.

- Use the plastigauge to read the clearance at the widest portion, which is specified as follows :

Camshaft journal oil clearance (IN. & EX.)	Service limit
	0.15 mm (0.006 in)

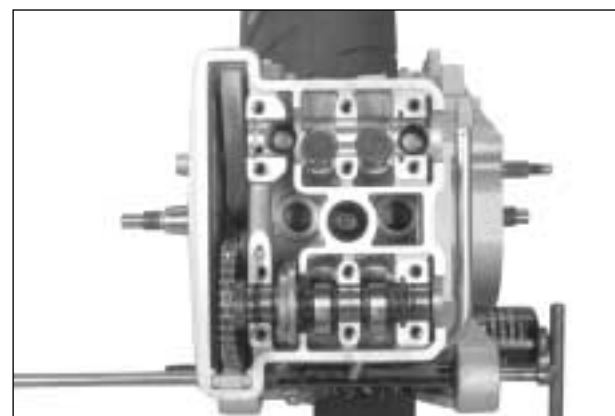

3-23 ENGINE

If the camshaft journal oil clearance exceeds the service limit, measure the inside diameter of the camshaft housing and outside diameter of the camshaft journal. Replace the camshaft or the cylinder head and camshaft housing depending upon which one exceeds the specification.

Camshaft housing I.D	Standard
IN.	21.959 ~ 21.980 mm
EX.	(0.8645 ~ 0.8654 in)

 **Small bore gauge : 09900-22401**

Camshaft O.D	Standard	
	<i>MSB 250</i>	<i>MSB 125</i>
IN.	21.959 ~ 21.980 mm	21.959 ~ 21.980 mm
EX.	(0.8645 ~ 0.8654 in)	(0.8645 ~ 0.8654 in)

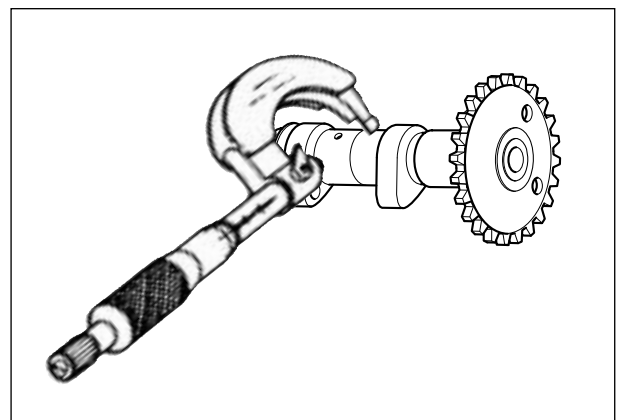
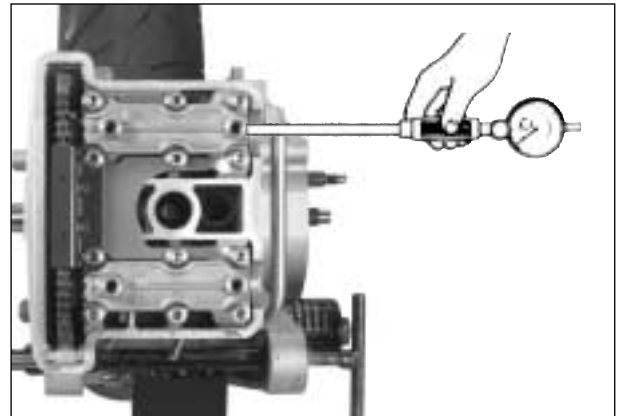

▣ CAMSHAFT RUNOUT

Support the valve using a V-blocks and measure the camshaft runout using the dial gauge. If the runout exceeds the service limit, replace the camshaft with a new one.

Camshaft runout (IN. & EX.)	Service limit
	0.10 mm (0.004 in)

 **Dial gauge : 09900-20606**

Magnetic stand : 09900-20701

V-block : 09900-21304

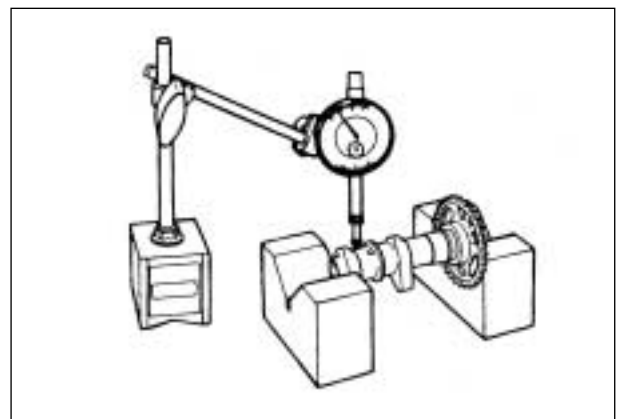

CYLINDER

▣ CYLINDER DISTORTION

Check the gasketed surface of the cylinder for distortion using a straightedge and thickness gauge, taking a clearance reading at several places as indicated. If the largest reading at any position of the straightedge exceeds the limit, replace the cylinder.

Cylinder distortion	Service limit
	0.05 mm (0.002 in)

 **Thickness gauge : 09900-20806**

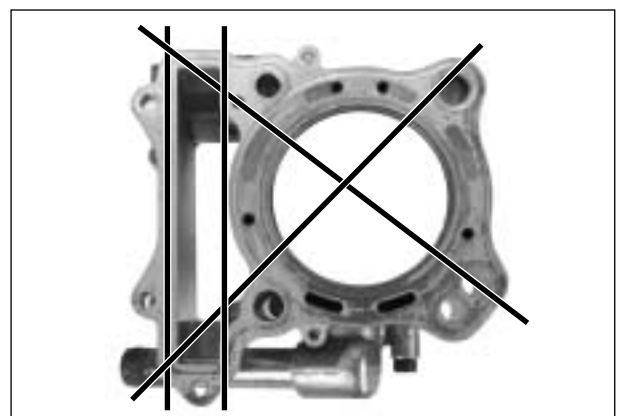

▣ CYLINDER BORE

Measure the cylinder bore diameter at six place. If any one of the measurements exceeds the limit, overhaul the cylinder and replace the cylinder.

MSA 250		
	Standard	Service limit
Cylinder bore	73.000 ~ 73.015 mm (2.8740 ~ 2.8746 in)	73.080 mm (2.8772 in)

MSA 125		
	Standard	Service limit
Cylinder bore	57.000 ~ 57.015 mm (2.2441 ~ 2.2447 in)	57.080 mm (2.2472 in)

 Cylinder gauge set : 09900-20508

CAM CHAIN TENSION ADJUSTER AND TENSIONER

▣ CAM CHAIN TENSION ADJUSTER

Check that the push rod slides smoothly with the lock shaft handle ① counter-clockwise. If it does not slide smoothly, replace the cam chain tension adjuster with a new one.

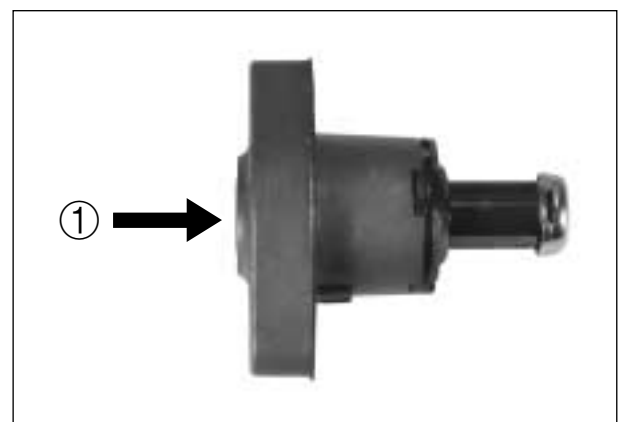
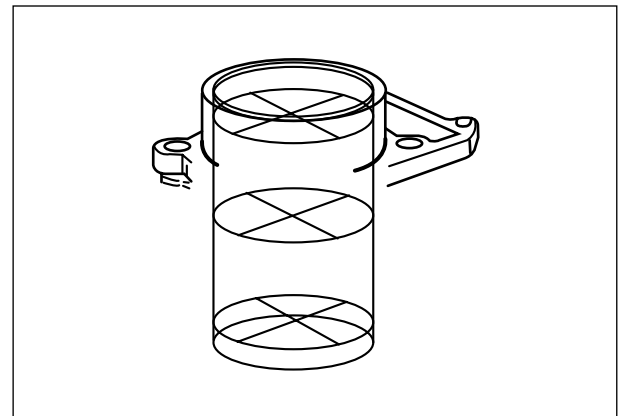

▣ CAM CHAIN TENSIONER

Check the contacting surface of the cam chain tensioner. If it is worn or damaged, replace it with a new one.

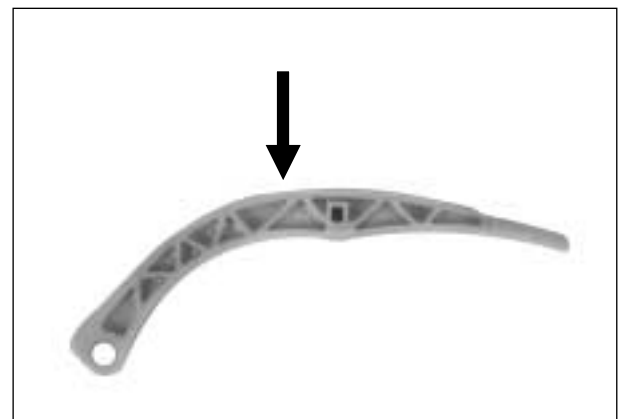

▣ CAM CHAIN AND CAM CHAIN GUIDE

Check the cam chain for wear, damage and kinked or binding links. If any defects are found, replace it with a new one.

Check the cam chain guide for wear and damage. If it is found to be damaged, replace it with a new one.

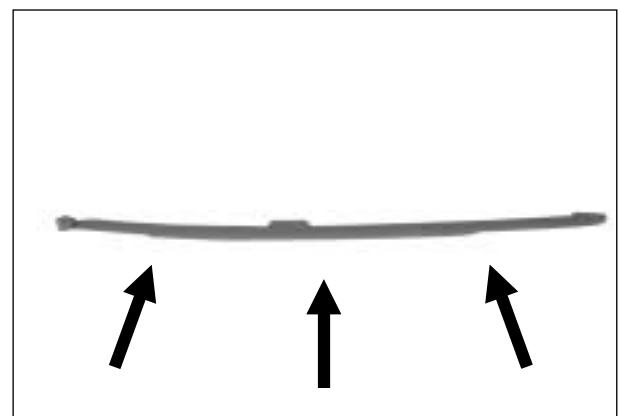

PISTON AND PISTON RING

▣ PISTON DIAMETER INSPECTION

Measure the outside diameter of piston in the direction perpendicular to the piston pin axis at the height from the skirt as shown in the illustration using a micrometer.

If the measurement is found less than the service limit, replace the piston.

Piston diameter	Service limit	
	<i>MSB 250</i>	<i>MSB 125</i>
	72.880 mm (2.8693 in)	56.880 mm (2.2394 in)

 Micrometer(50 ~ 75 mm) : 09900-20203

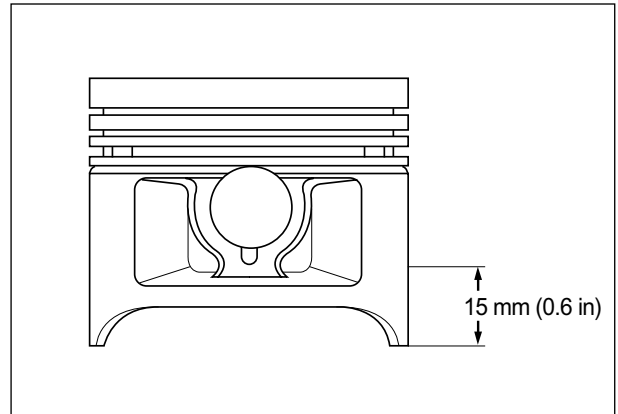

▣ PISTON-TO-CYLINDER CLEARANCE

To determine the piston-to-cylinder clearance, calculate the difference between the cylinder bore and outside diameter of the piston.

Piston-to-cylinder clearance	Standard	Service limit
	0.050~0.060 mm (0.0020~0.0024 in)	0.120 mm (0.0047 in)

 Micrometer(0 ~ 25 mm) : 09900-20201

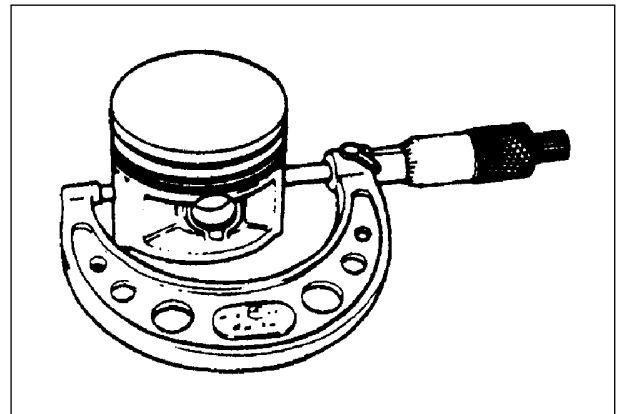

▣ PISTON PIN HOLE BORE

Using a dial calipers, measure the piston pin hole bore both the vertical and horizontal directions.

If the measurement exceeds the service limit, replace the piston with a new one.

Piston pin hole bore	Service limit	
	<i>MSB 250</i>	<i>MSB 125</i>
	19.030 mm (0.7492 in)	15.030 mm (0.5917 in)

 Dial calipers : 09900-20605

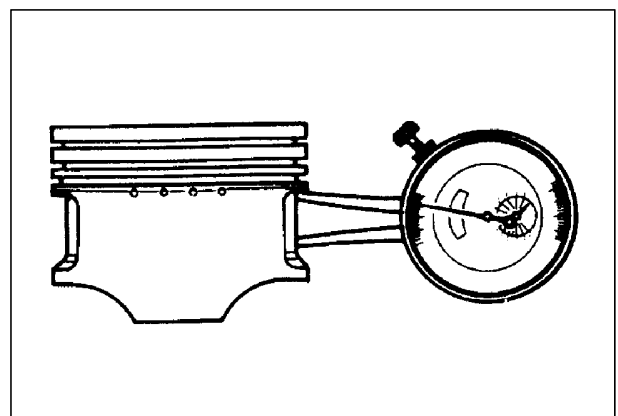

▣ PISTON PIN DIAMETER INSPECTION

Using a micrometer, measure the piston pin outside diameter at three position, both the ends and the center.

If any of the measurements is founds less than the service limit, replace the pin with a new one.

Piston pin diameter	Service limit	
	<i>MSB 250</i>	<i>MSB 125</i>
	18.980 mm (0.7472 in)	14.980 mm (0.5898 in)

 **Micrometer(0~25 mm) : 09900-20201**

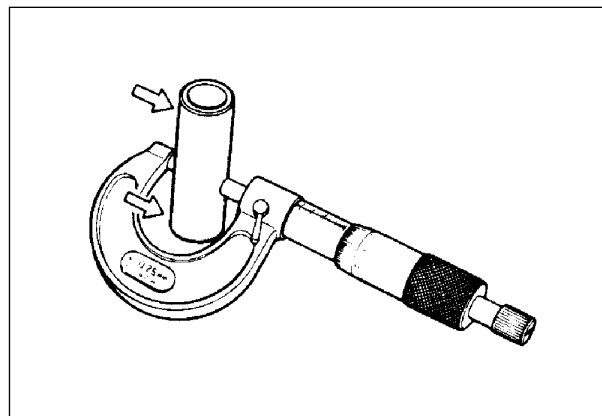

▣ PISTON RING FREE END GAP INSPECTION

Before installing piston rings, measure the free end gap of each ring using vernier calipers. If the gap is less than the service limit, replace the ring.

Piston ring free end gap	Service limit	
	<i>MSB 250</i>	<i>MSB 125</i>
1st	8.0 mm (0.315 in)	5.7 mm (0.224 in)
2nd	6.8 mm (0.268 in)	4.6 mm (0.181 in)

 **Vernier calipers : 09900-20101**

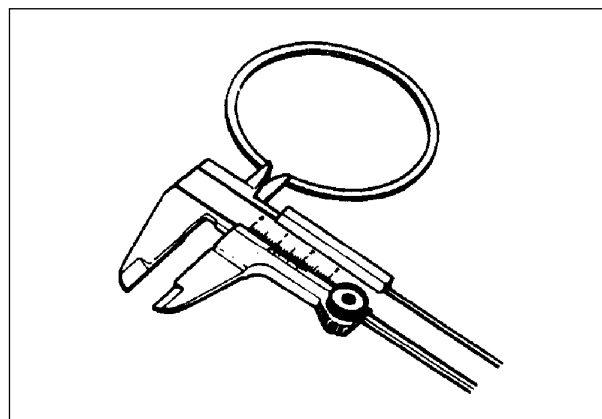

▣ PISTON RING END GAP INSPECTION (Assembly condition)

Insert the piston ring squarely into the cylinder using the piston head.

Measure the end gap with a thickness gauge.

If the gap exceeds the service limit, replace the piston ring with a new one.

Piston ring end gap (Assembly condition)	Standard	
	<i>MSB 250</i>	<i>MSB 125</i>
1st	0.10 ~ 0.30 mm (0.004 ~ 0.012 in)	0.20 ~ 0.32 mm (0.008 ~ 0.013 in)
2nd	0.35 ~ 0.50 mm (0.014 ~ 0.020 in)	0.20 ~ 0.32 mm (0.008 ~ 0.013 in)

Piston ring end gap(Assembly condition)	Service limit
1st	0.5 mm (0.020 in)
2nd	0.5 mm (0.020 in)

 **Thickness gauge : 0990-20806**

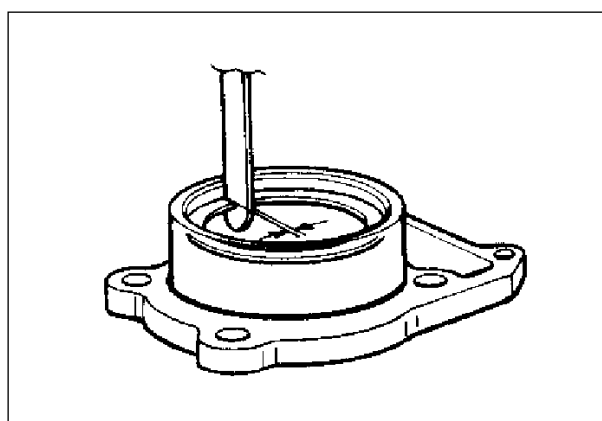

▣ PISTON RING-TO-GROOVE CLEARANCE INSPECTION

Remove carbon deposit both from the piston ring and its groove.

Fit the piston ring into the groove. With the ring compressed and lifted up, measure the clearance on the bottom side of the ring using a thickness gauge.

If any clearance reading exceeds the service limit, replace both the piston and piston rings.

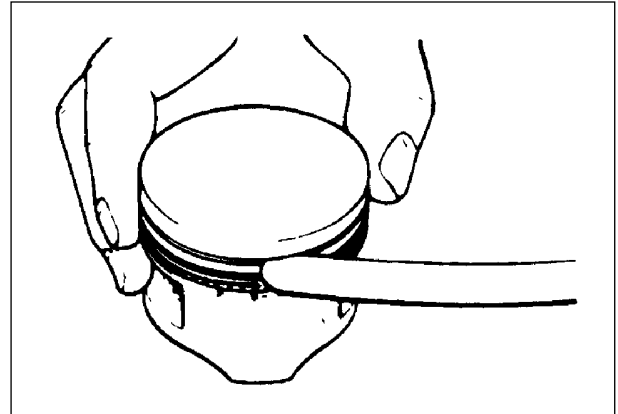

Piston ring-groove clearance	Service limit
1st	0.180 mm (0.007 in)
2nd	0.150 mm (0.006 in)

Piston ring groove width	Standard
1st	1.01 ~ 1.03 mm (0.040 ~ 0.041 in)
2nd	1.01 ~ 1.03 mm (0.040 ~ 0.041 in)
Oil	2.01 ~ 2.03 mm (0.079 ~ 0.080 in)

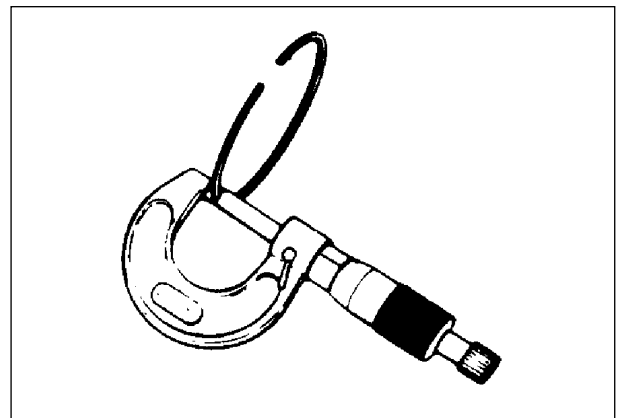

Piston ring thickness	Standard
1st	0.970 ~ 0.990 mm (0.0382 ~ 0.0390 in)
2nd	0.970 ~ 0.990 mm (0.0382 ~ 0.0390 in)

TOOL Micrometer(0~25 mm) : 09900-20201
 Thickness gauge : 09900-20806

CONROD

▣ CONROD SMALL END INSIDE DIAMETER INSPECTION

Using a dial calipers, measure the conrod small end inside diameter both in vertical and horizontal directions.

If any of the measurements exceeds the service limit, replace the conrod.

MSB 250		
Conrod small end I.D.	Standard	Service limit
	19.006 ~ 19.014 mm (0.7483 ~ 0.7486 in)	19.040 mm (0.7496 in)

MSB 125		
Conrod small end I.D.	Standard	Service limit
	15.006 ~ 15.014 mm (0.5908 ~ 0.5911 in)	15.040 mm (0.5921 in)

 **Dial calipers : 09900-20605**

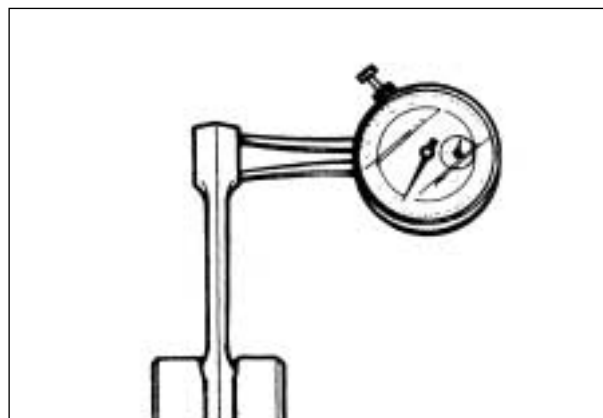

▣ CONROD DEFLECTION INSPECTION

Wear on the big end of the conrod can be estimated by checking the movement of the small end of the rod.

Turn the conrod and see if it moves smoothly without play and noise. This method can also be used to check the extent of wear on the parts of the conrod's big end.

Conrod deflection	Service limit
	3.0 mm (0.12 in)

 **Dial gauge : 09900-20606**

Magnetic stand : 09900-20701

V-block : 09900-21304

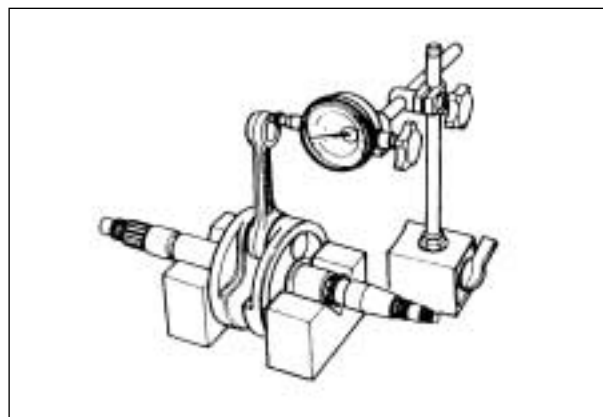

CONROD BIG END SIDE CLEARANCE INSPECTION

Push the big end of the conrod to one side and measure the side clearance using a thickness gauge. If the clearance exceeds the service limit, replace the crankshaft assembly with a new one or bring the deflection and the side clearance within the service limit by replacing the worn parts (conrod, big end bearing, crankshaft, crank pin, etc.) with new ones.

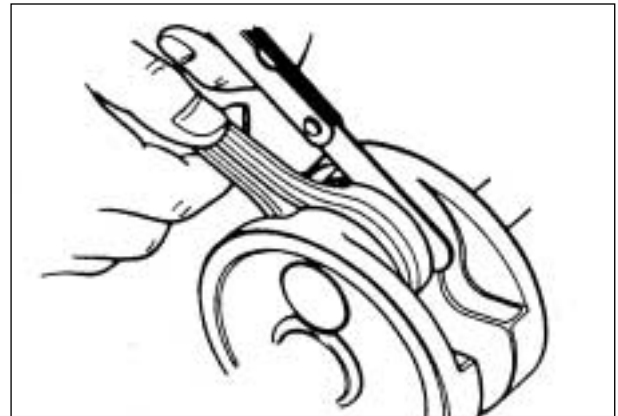

Conrod big end side clearance	Standard	Service limit
	0.10 ~ 0.45 mm (0.004 ~ 0.018 in)	1.0 mm (0.040 in)

 Thickness gauge : 09900-20806

CRANKSHAFT

CRANKSHAFT RUNOUT INSPECTION

With the right and left crank journals supported using a V-block, turn the crankshaft slowly. At this time, measure the crankshaft end runout using a dial gauge. If the runout exceeds the service limit, replace the crankshaft with a new one.

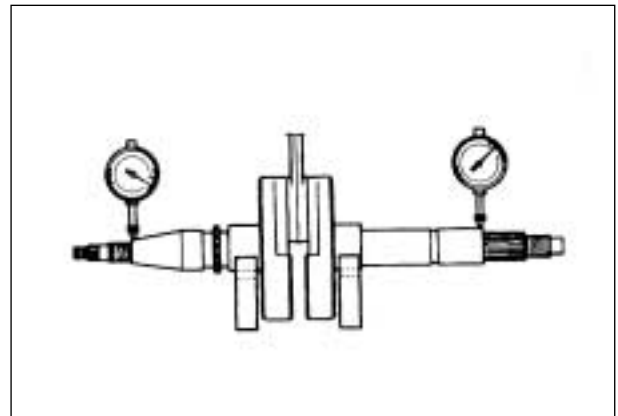

	
Crankshaft runout	Service limit
	0.01 mm (0.0004 in)

	
Crankshaft runout	Service limit
	0.03 mm (0.0012 in)

 Dial gauge : 09900-20606
 Magnetic stand : 09900-20701
 V-block : 09900-21304

CRANK BALANCER AND BALANCER DRIVEN GEAR

(Only for 『MSB 250』)

▣ DISASSEMBLY

- Disassemble the crank balancer and balancer driven gear as shown in the illustration.

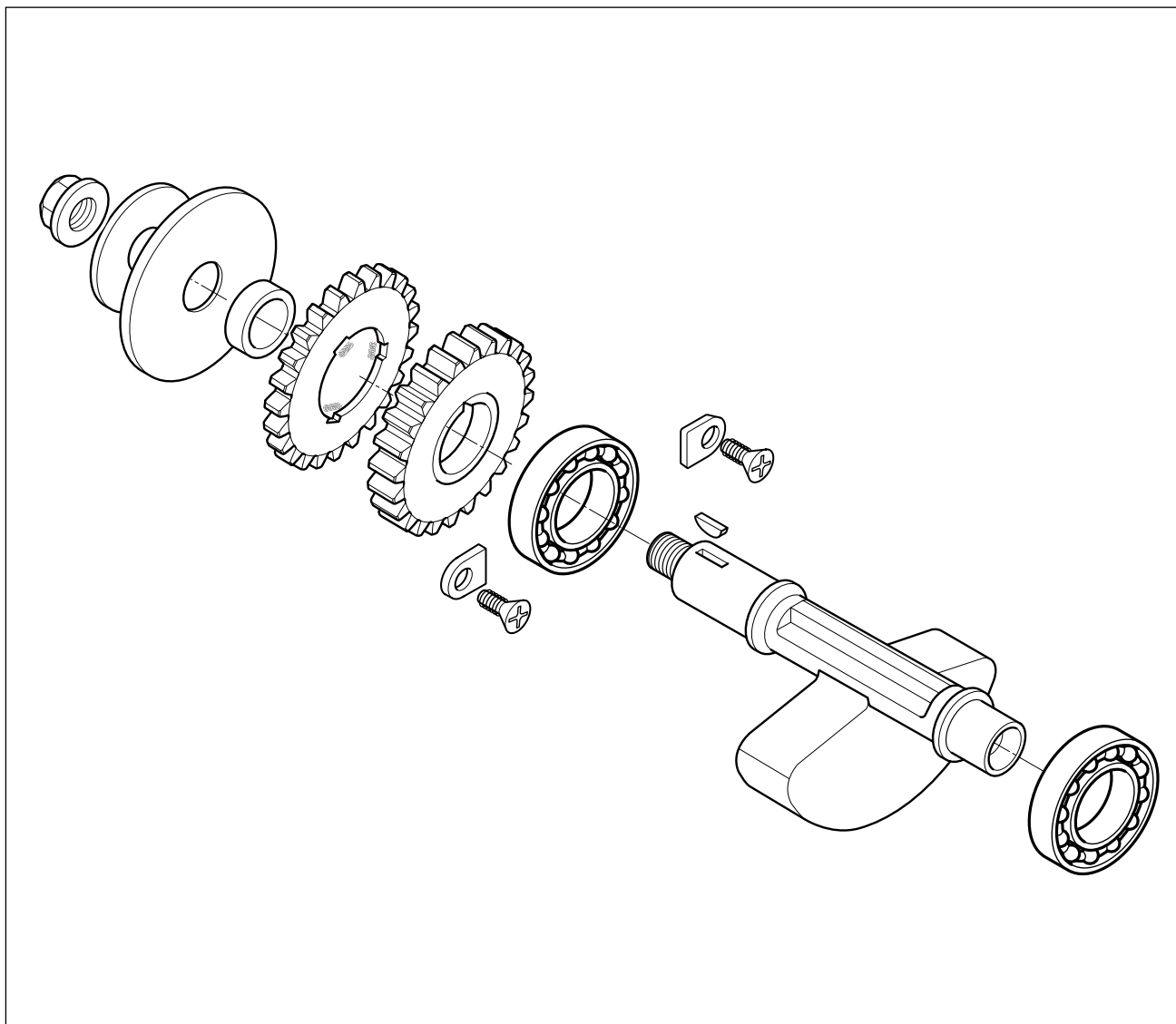

▣ REASSEMBLY

Reassemble the crank balancer and balancer driven gear in the reverse order of disassembly.

MOVABLE DRIVE FACE

▣ ROLLER INSPECTION

Inspect each roller and its sliding surface for abnormal wear or damage. Measure the diameter of roller with a vernier calipers. If any defects are found or measurement exceeds the limit, replace the rollers as a set.

Movable drive face roller O.D.	Service limit	
	<i>MSB 250</i>	<i>MSB 125</i>
	20.4 mm (0.80 in)	16.4 mm (0.65 in)

 Vernier calipers : 09900-20101

▣ MOVABLE DRIVE FACE INSPECTION

Inspect the belt contacting surface of movable drive face for scratches or discoloration caused by burring. If any defects are found, replace the movable drive face with a new one.

▣ REASSEMBLY

- Install the six rollers.
- Install the movable drive plate ① into the movable drive face ②.
- Fix the movable drive cover with the screws.
- Install the spacer ③.

 **CAUTION**

The drive belt contact surfaces of the movable drive face should be cleaned to be free from oil.

Refer to page 3-51 for installation of the movable drive face.

CLUTCH SHOE / MOVABLE DRIVE FACE

▣ DISASSEMBLY

- Loosen the clutch shoe nut with the special tool.

 Rotor holder : 09930-40113

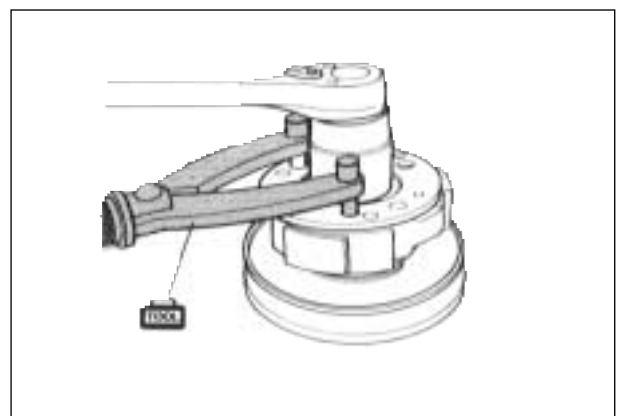
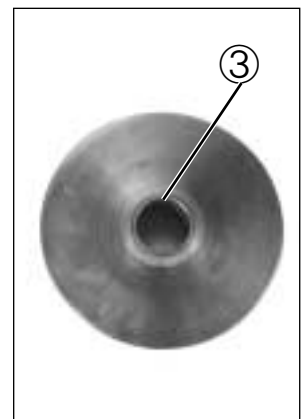
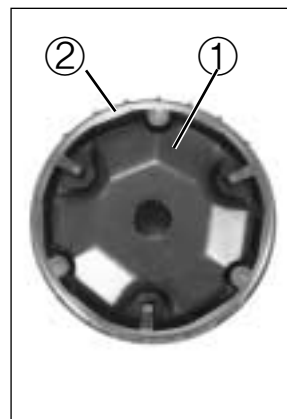
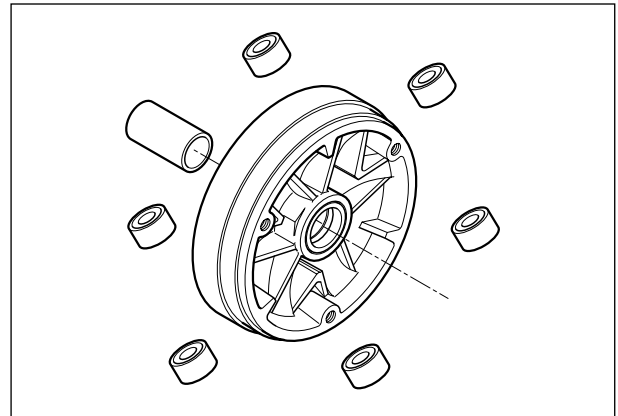

- Remove the clutch shoe nut while holding down the clutch shoe assembly by hand.

⚠ WARNING

Gradually back off the clutch shoe assembly pressed down by hand to reduce the clutch spring load.

Releasing the hand suddenly may cause the parts to fly apart.

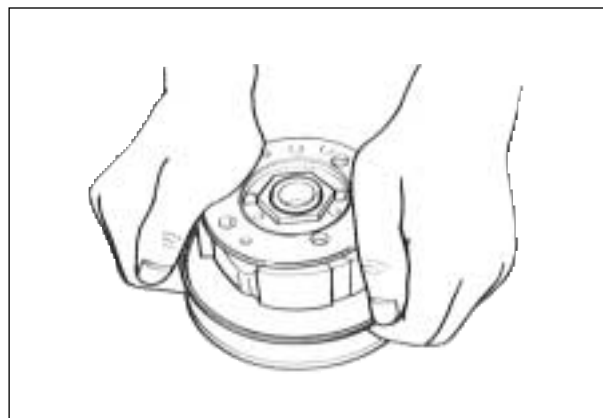

- ① Clutch shoe nut
- ② Clutch shoe assembly
- ③ Spring

⚠ CAUTION

Do not attempt to disassemble the clutch shoe assembly.

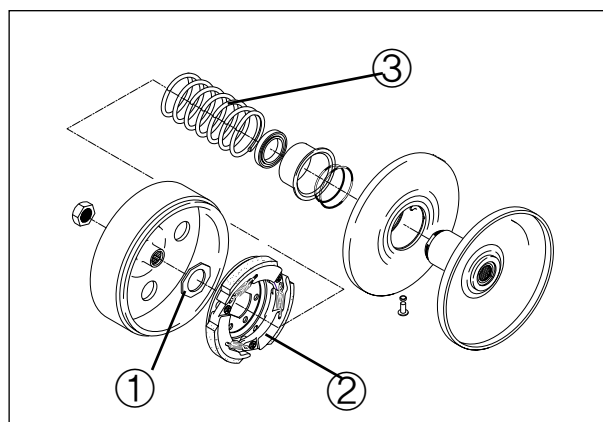

- Remove the movable driven face seat ④ with a thin blade screwdriver.

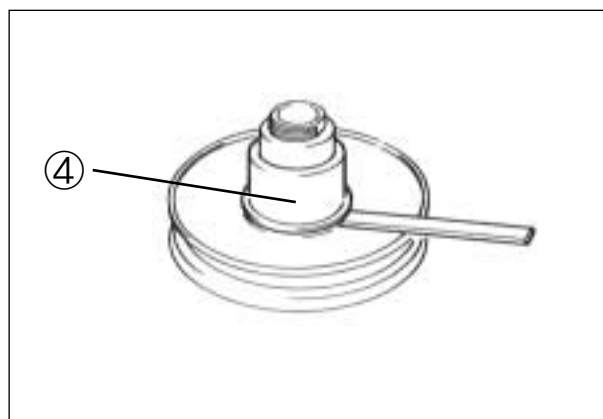

- Remove the three pins ⑤ and movable driven face ⑥ from the fixed driven face ⑦.

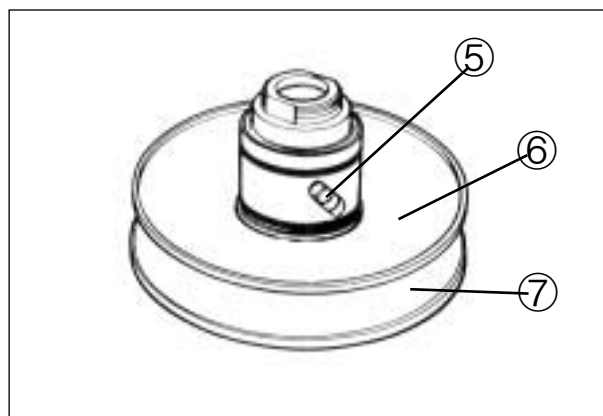

CLUTCH SHOE INSPECTION

Inspect the linings for crack, uneven wear or burning. Measure the lining thickness with a vernier calipers. If any defects are found or measurement exceeds the limit, replace the clutch shoe assembly with a new one.

Clutch shoe thickness	Service limit 1.0 mm (0.04 in)
------------------------------	--

 Vernier caliper : 09900-20101

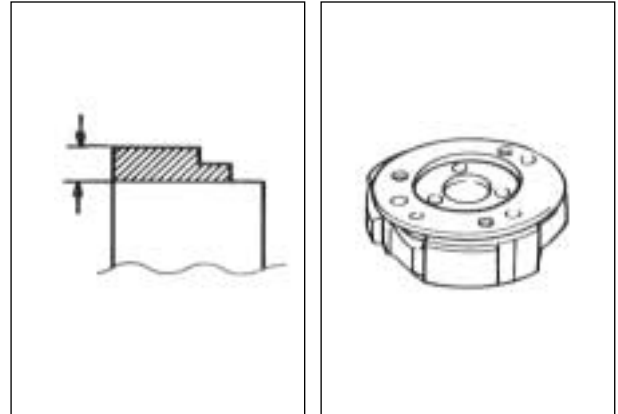

CLUTCH HOUSING INSPECTION

Inspect the inner surface of clutch housing for deep scratches or discoloration caused by burning. Measure the clutch housing inside diameter with an inside calipers. If any defects are found or measurement exceeds the limit, replace the clutch housing with a new one.

MSB 650	
Clutch housing I.D.	Service limit 134.5 mm (5.295 in)

MSB 125	
Clutch housing I.D.	Service limit 125.5 mm (4.941 in)

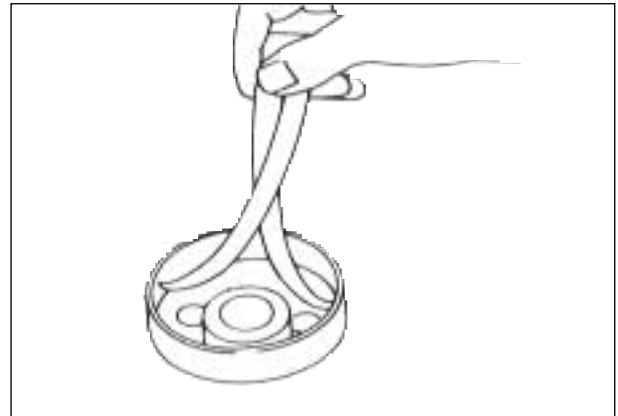

MOVABLE DRIVEN FACE SPRING INSPECTION

Measure the free length of movable driven face spring. If length is shorter than the service limit, replace the spring with a new one.

MSB 650	
Movable driven face spring free length	Service limit 124.0 mm (4.88 in)

MSB 125	
Movable driven face spring free length	Service limit 70.0 mm (2.76 in)

 Vernier caliper : 09900-20101

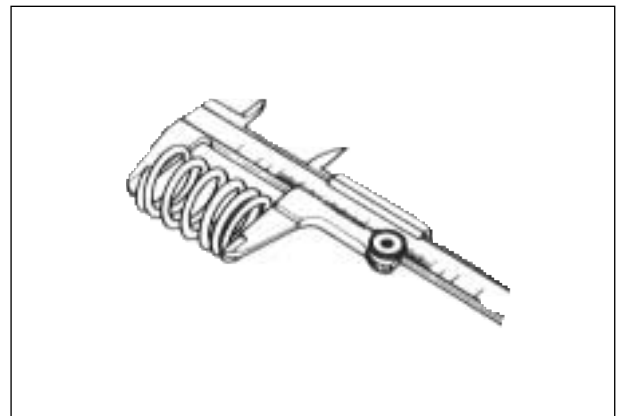

▣ DRIVE BELT INSPECTION

Inspect the drive belt for crack, separation, abnormal wear or contamination with oil.

Measure the belt width with a vernier calipers.

If any defects are found or width is less than the service limit, replace the drive belt with a new one.

Drive belt width	Service limit	
	<i>MSB 650</i>	<i>MSB 125</i>
	22.5 mm (0.89 in)	19.6 mm (0.77 in)

 Vernier caliper : 09900-20101

CAUTION

Always keep the drive belt away from any greasy matter.

If drive belt is contaminated with grease or oil, clean it with neutral detergent.

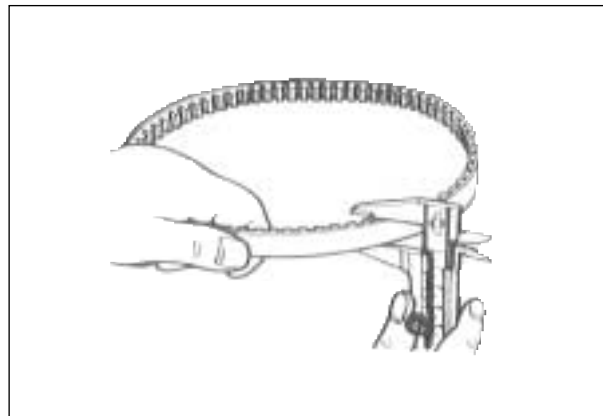





▣ REASSEMBLY

- Install the movable driven face to the fixed driven face.

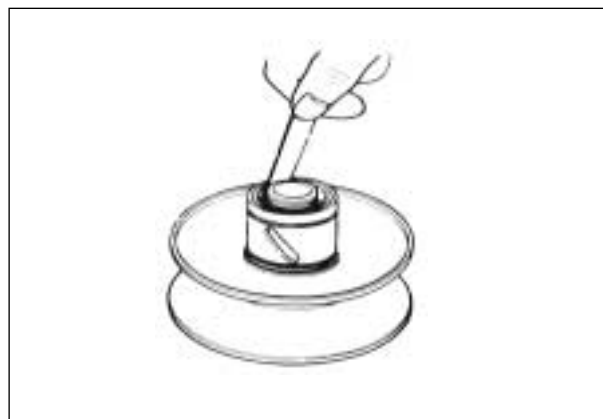
CAUTION

When installing the movable driven face, insert it while using a 0.1 mm thickness gauge as a guide to prevent the damage of the oil seal lip.



- Install the three pins  and the new O-rings .
- Apply **SUPER GREASE "A"** to the pin groove and O-rings .

 **SUPER GREASE "A"**

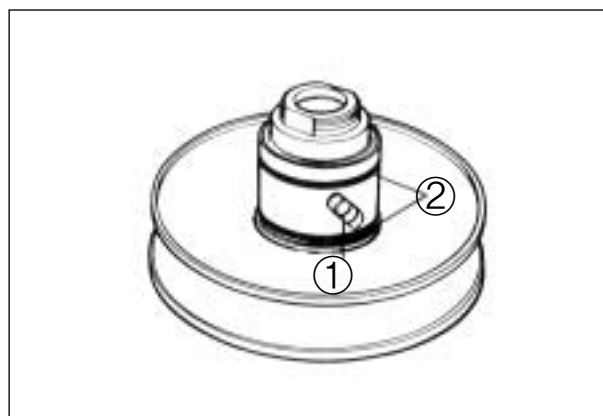

3-35 ENGINE

- Install the movable driven face seat ①.

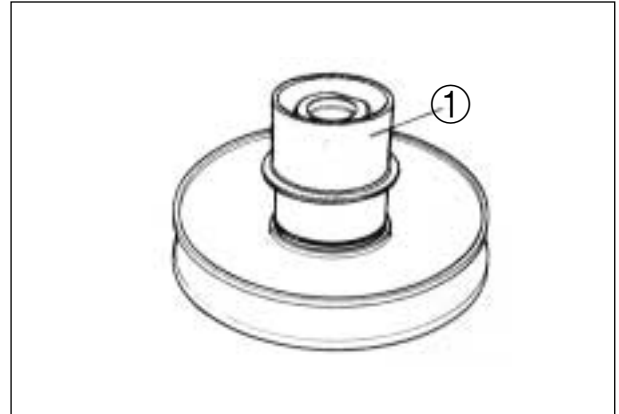

- Install the spring and clutch shoe assembly ②.
- Install the clutch shoe nut ③ while pressing down the clutch shoe assembly.

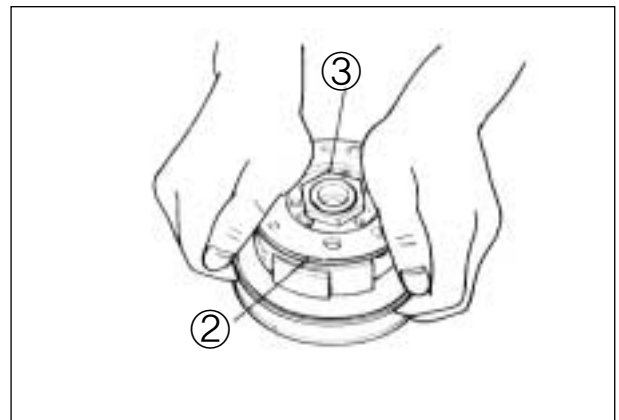

- Tighten the clutch shoe nut ④ to the specified torque with the special tool.

 **Clutch shoe nut : 50 N · m (5.0 kgf · m)**

 **Rotor holder : 09930-40113**

Refer to page 3-51 installation of the movable driven face and clutch.

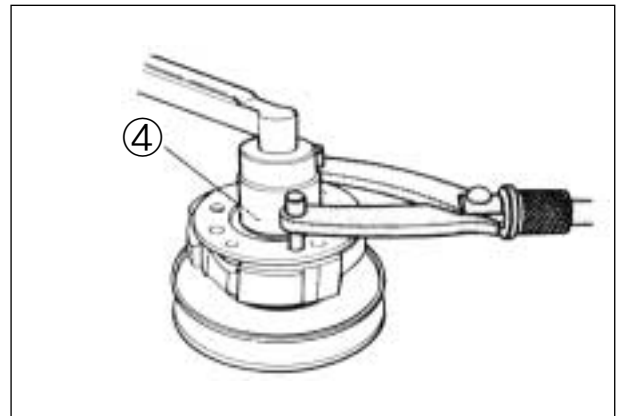

BELT ROLLER

(Only for 『MSA 250』)

Ensure that the belt roller shows no signs of irregular wear and can turn freely.

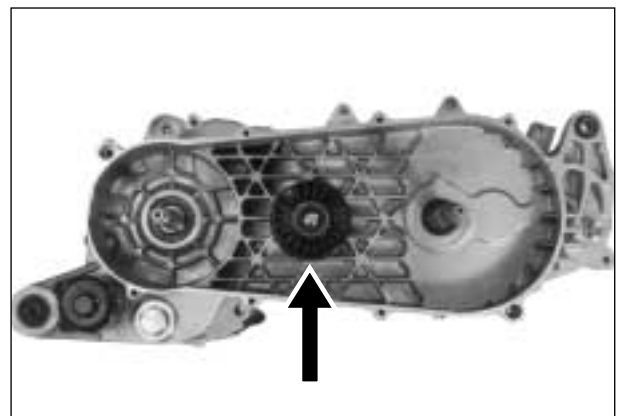

CRANKCASE OIL SEAL, BEARING AND BUSHING

▣ BEARING INSPECTION

Rotate the bearing inner race by finger to inspect for abnormal play, noise and smooth rotation while the bearings are in the crankcase.

Replace the bearing if there is anything unusual.

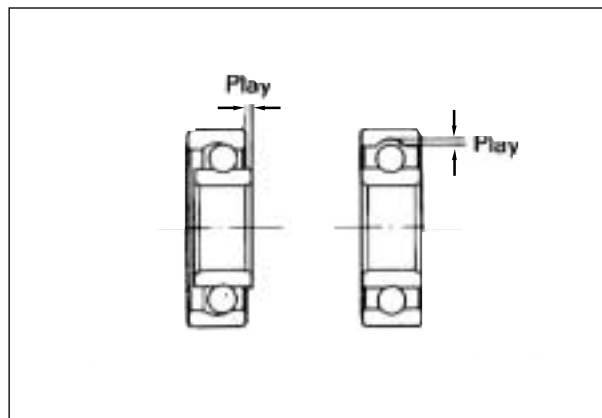

▣ OIL SEAL INSPECTION

Damage to the lip of the oil seal may result in leakage of the fuel-air mixture or oil. Inspect for damage and be sure to replace the damaged seal if found.

▣ BUSHING INSPECTION

Inspect the bushing for wear or damage.

If any defects are found, replace the bushing with a new one.



STARTER CLUTCH

▣ INSPECTION OF STARTER CLUTCH OPERATION

- Turn the starter clutch gear by hand in the direction of arrow as shown and check that rotation is smooth. Also check that the gear is locked when attempted to turn in the other direction.
- If a large resistance is felt or noise occurs when turning the gear, check the starter clutch gear sliding surface for wear or damage.
- If any abnormal condition is found, replace the starter clutch with a new one.



ENGINE REASSEMBLY

Reassemble the engine in the reverse order of disassembly.
Pay special attention to the following points :

NOTE

- ❖ *Apply engine oil to each running and sliding part before reassembling the engine.*
- ❖ *Always keep the drive belt, drive faces and driven faces away from any greasy matter.*

⊙ CRANKSHAFT

- Install the jet ①.

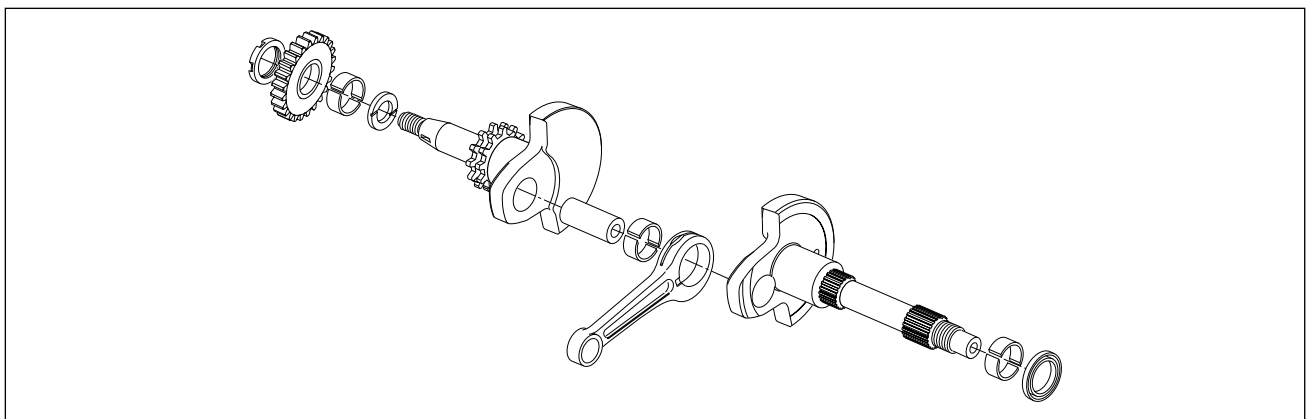
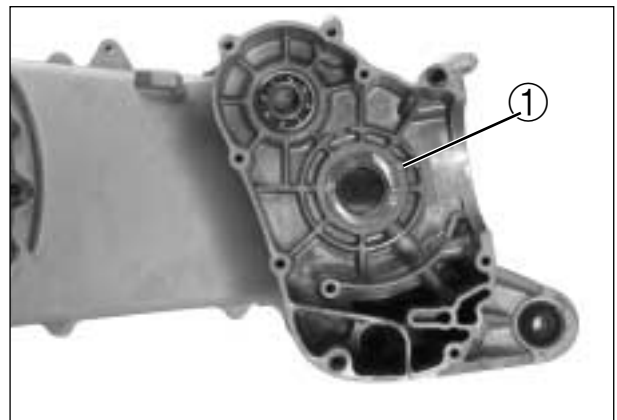

- Determine the width between the webs referring to the figure when rebuilding the crankshaft.

Width between webs	Standard
	51.0 ± 0.1 mm (2.008 ± 0.004 in)

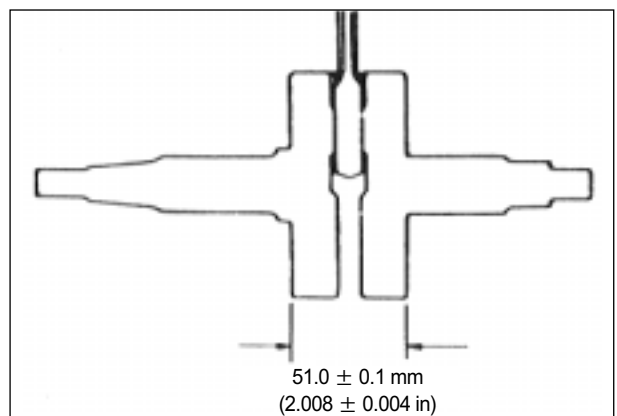

- Install the crankshaft① into the left crankcase half.

⚠ CAUTION

Never strike the crankshaft with a plastic hammer when inserting it into the crankcase.
It will be easy to install the crankshaft to left crankcase.

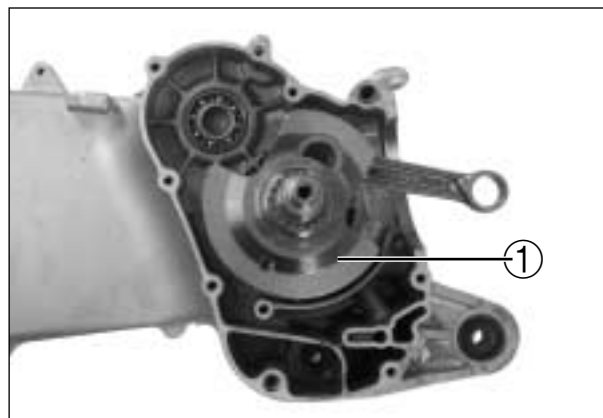

⊙ CRANKCASE

- Install the crank balancer②.
(Only for 『MSB 350』)
- Clean and degrease the crankcase mating surfaces (both surfaces) with a cleaning solvent.
- Fit the dowel pins③ into the left crankcase.
- Apply BOND “1215” to the right crankcase.

1215 BOND “1215”

⚠ CAUTION

- ❖ Coat the sealant evenly without break.
- ❖ Application of sealant must be performed within a short period of time.
- ❖ Take extreme care not to let sealant enter into the oil hole or bearing.

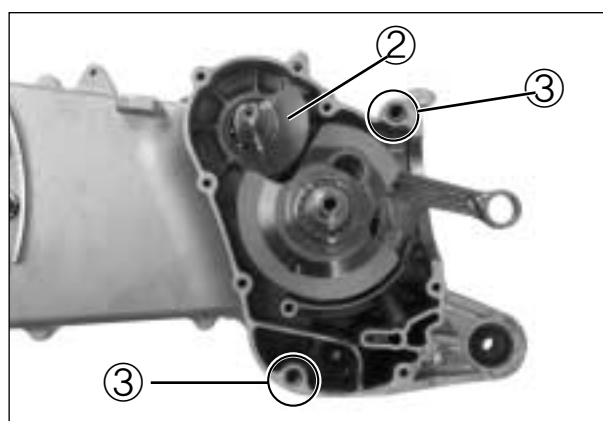

- Assemble the crankcases with in few minutes.
- Tighten the crankcase bolts diagonally and evenly.



Crankcase bolt

: 8 ~ 12 N · m (0.8 ~ 1.2 kgf · m)

NOTE

After crankcase bolts have been tightened, check it crankshaft rotate smoothly.

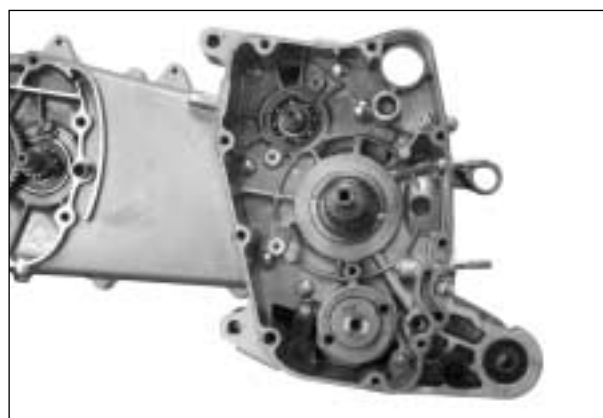

⊙ REAR AXLE SHAFT

- Install the final driven gear ① and rear axle shaft ② to the gear box cover.
- Install the circlip ③.

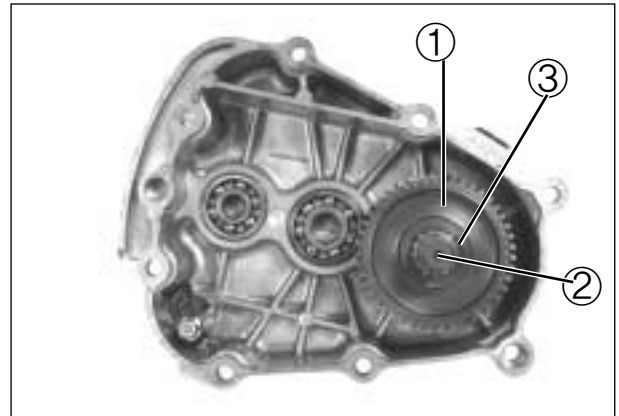

⊙ IDLE SHAFT

- Install the idle shaft ④, idle driven gear ⑤ and drive shaft ⑥.



CAUTION

Apply engine oil to each gear and shaft.

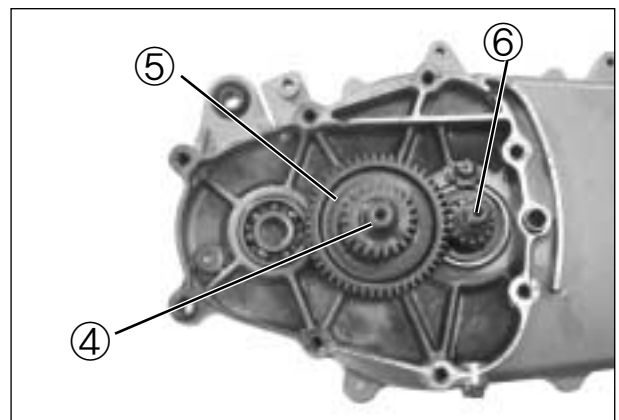

⊙ GEAR BOX COVER

- Install the dowel pins and the gasket.
- Install the gear box cover ⑦ together with the rear axle shaft ⑧.



Gear box cover bolt

: 18 N · m (1.8 kgf · m)

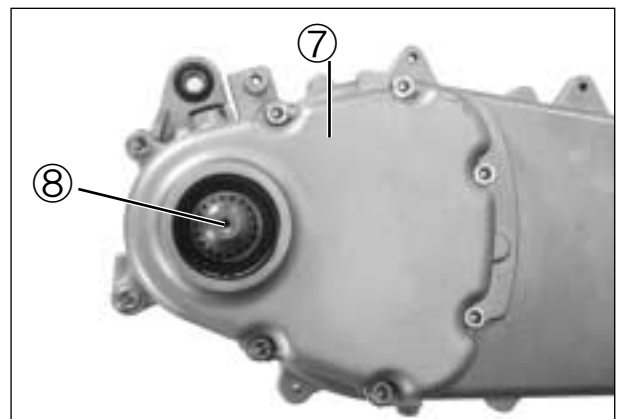

⊙ REAR WHEEL

- Install the rear wheel ⑨ and then install the rear axle spacer ⑩.

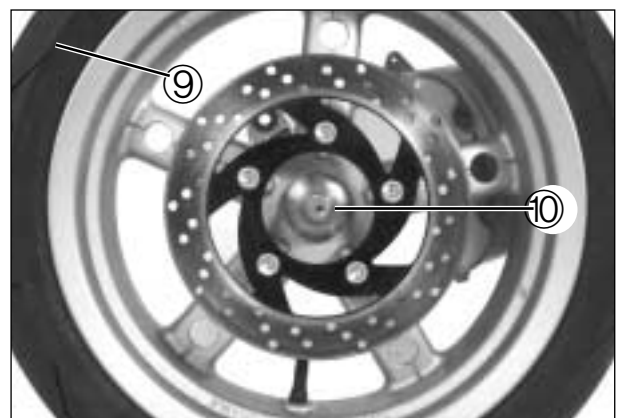

⊙ CRANK BALANCER GEAR

- When installing the crank balancer driven No.1 gear ①, align the pawl A of the crank balancer with the recess B of the crank balancer driven No.1 gear ①. (Only for 『MSB 450』)
- When installing the crank balancer drive gear ②, align the pawl C of the crankshaft with the recess D of the crank balancer drive gear ②. (Only for 『MSB 450』)

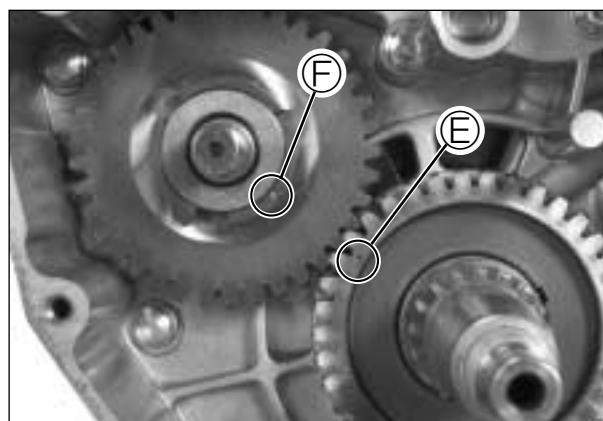
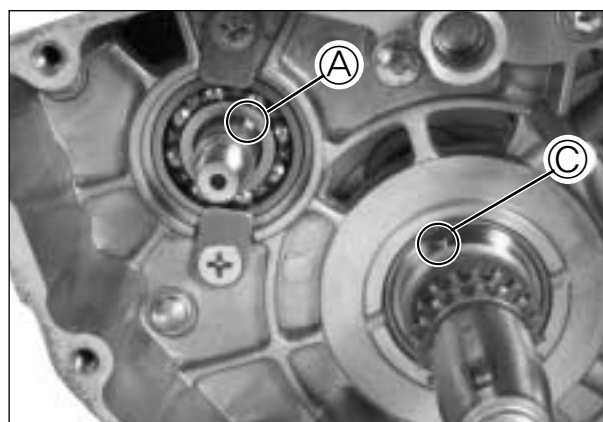
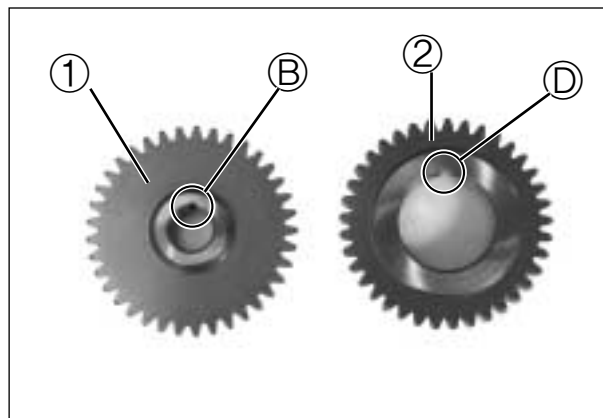

⚠ CAUTION

Make sure that the punch mark E on the balancer drive gear is aligned with the punch mark F on the balancer driven No.1 gear.
(Only for 『MSB 450』)

- Hold the crankshaft immovable using the special tool.

 **Conrod holder : 09910-20115**

- Using the special tool, tighten the balancer drive gear nut ③ to the specified torque.

 **Crank balancer socket wrench
: 09940HP7600**

 **Crank balancer drive gear nut
: 100 ~ 120 N · m (10.0 ~ 12.0 kgf · m)**

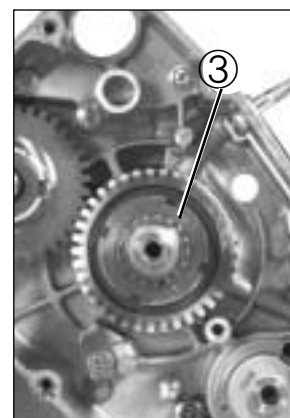

⊙ PISTON RING

- Install the oil ring first, the 2nd ring second, and the 1st ring last.

NOTE

- ❖ The 1st ① and 2nd ② piston rings differ in shape.
- ❖ The 1st and 2nd piston rings should be installed with the mark facing up.

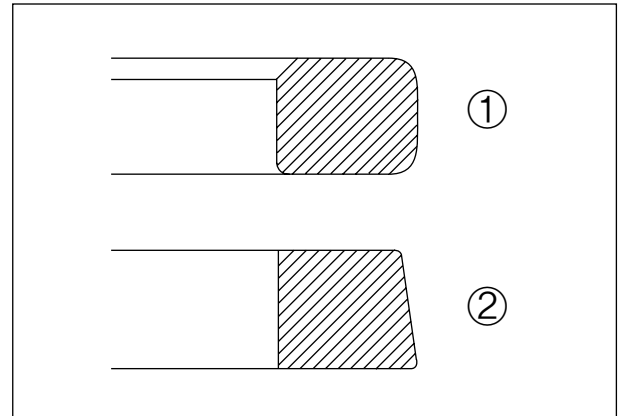

- First, install a spacer ③ into the oil ring groove, and then install the two side rails ④. The spacer and side rails do not have a designated top and bottom. They can be installed in any position.

⚠ CAUTION

When installing the spacer, be careful not to allow its two ends to overlap in the groove.

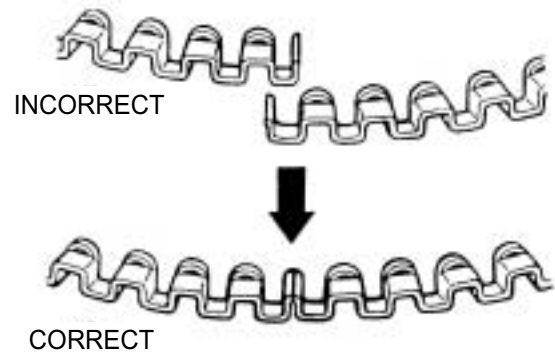
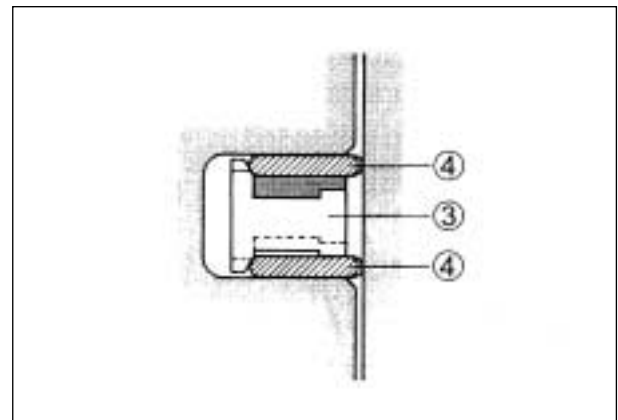

- Position the piston ring gaps as shown. Before inserting the piston into its cylinder, check that the gaps are properly positioned.

- ⑤ 2nd ring and lower side rail
- ⑥ Upper side rail
- ⑦ 1st ring and spacer

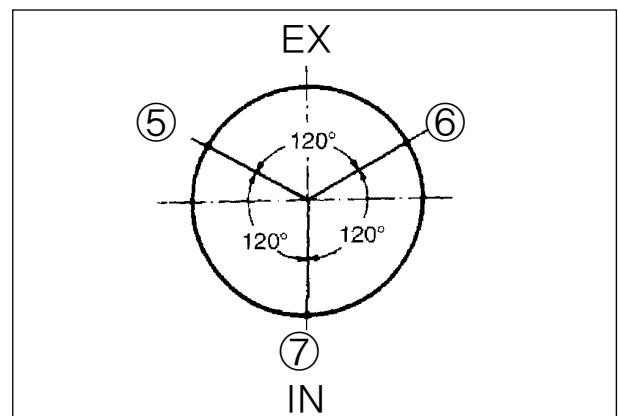

⊙ PISTON AND CYLINDER

- Apply **MOLY PASTE** on the piston pin and small end of the conrod.

 **MOLY PASTE**

NOTE

Install the piston with the punch mark ① on the piston head facing toward the exhaust side.

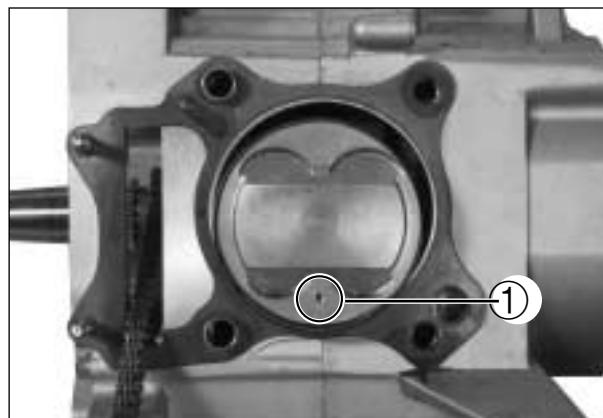

- Place a clean rag over the cylinder base to prevent the piston pin circlip from dropping into the crankcase, and then fit the piston pin circlip with long-nose pliers.

⚠ CAUTION

Use a new piston pin circlip to prevent circlip failure with a bent one.

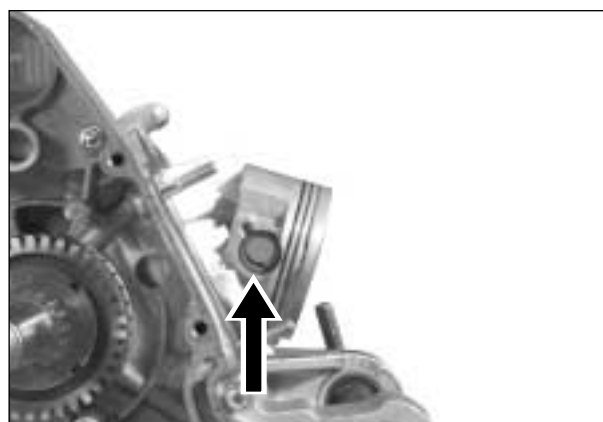

- Apply engine oil to the sliding surface of the piston and big end of the conrod.
- Install the dowel pins ② and new gasket ③ onto the crankcase.

⚠ CAUTION

Use a new gasket to prevent oil leakage.

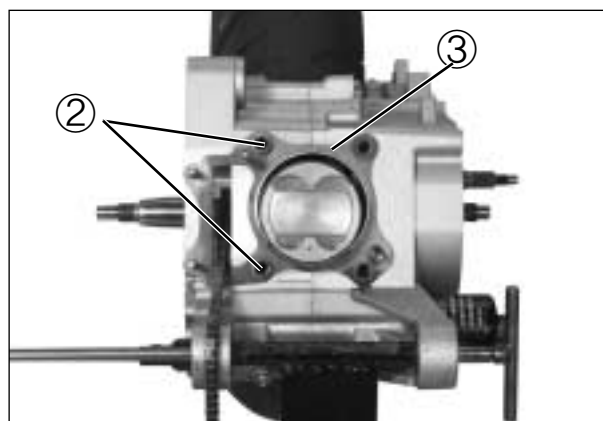

- Hold each piston ring with the piston ring sections positioned correctly and put it into the cylinder. Make sure that the piston rings are caught by the cylinder skirt.

NOTE

When mounting the cylinder, after attaching the cam chain, keep the cam chain taut. The cam chain must not be caught between the cam chain sprocket and crankcase when the crankshaft is rotated.



- Tighten the cylinder base nut ① to the specified torque.

🔧 Cylinder base nut

: 7 ~ 11 N · m (0.7 ~ 1.1 kgf · m)

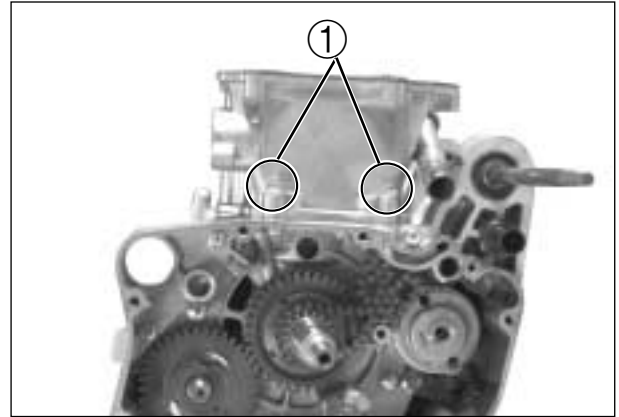

- Install the dowel pins ② and new gasket ③.

⚠ CAUTION

Use a new cylinder head gasket to prevent gas leakage.

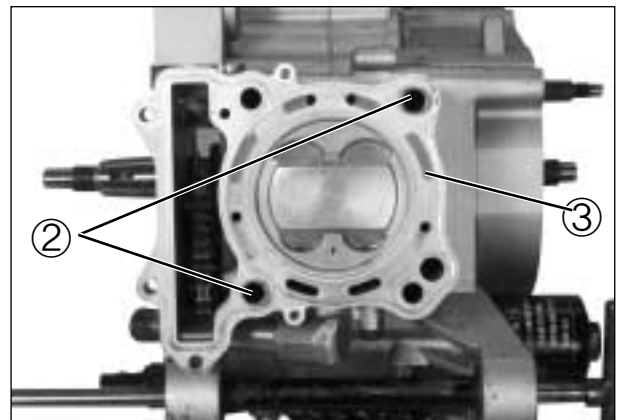

🔧 CYLINDER HEAD

- Install the cylinder head ④.
- Install the cam chain guide ⑤.

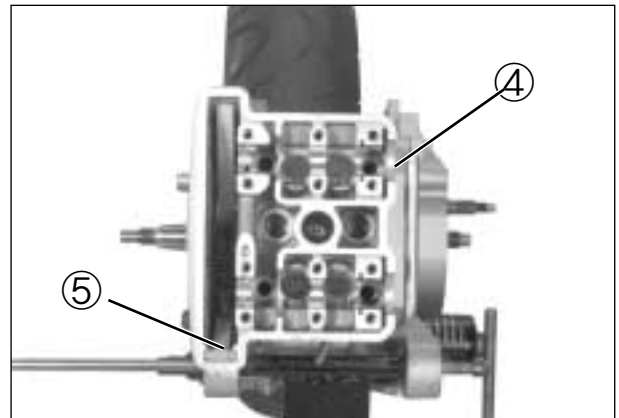

- With the head snugly seated on the cylinder, secure it by tightening the bolts in diagonal stages. Tighten the cylinder head bolts diagonally to the specified torque.

🔧 Cylinder head bolt

: 40 ~ 45 N · m (4.0 ~ 4.5 kgf · m)

NOTE

- ❖ Apply engine oil to the threaded parts of the cylinder head bolts and its washers.
- ❖ Be sure to install the washer with rounded side facing up.

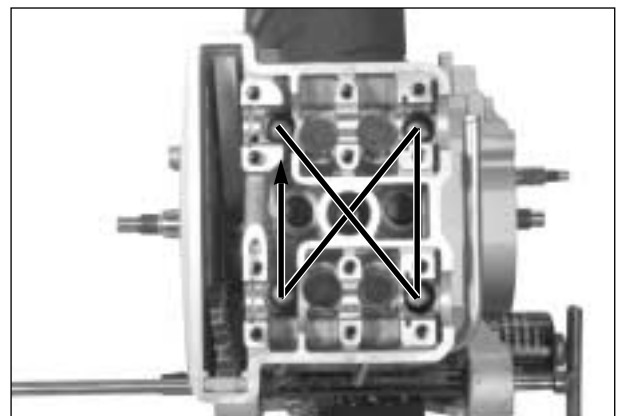

- After tightening the cylinder head bolts to the specification, tighten the cylinder head base nuts ① to the specified torque.

Cylinder head base nut

: 7 ~ 11 N · m (0.7 ~ 1.1 kgf · m)

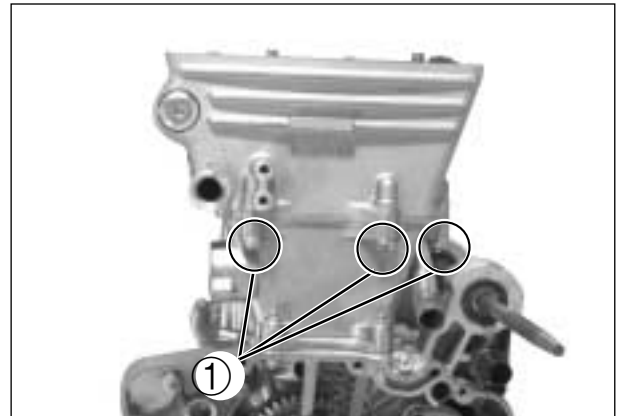

◎ CAMSHAFT ASSEMBLY

- Turn the crankshaft until the “—” line on the magneto rotor is aligned with the triangle mark on the magneto cover.

CAUTION

If the crankshaft is turned without drawing the cam chain upward, the cam chain will catch between crankcase and cam chain sprocket.



NOTE

Just before installing the camshaft into the cylinder head, apply MOLY PASTE to the camshaft journals and cam faces. Also, apply engine oil to the camshaft housing.

 MOLY PASTE

- Place each camshaft into the correct position.

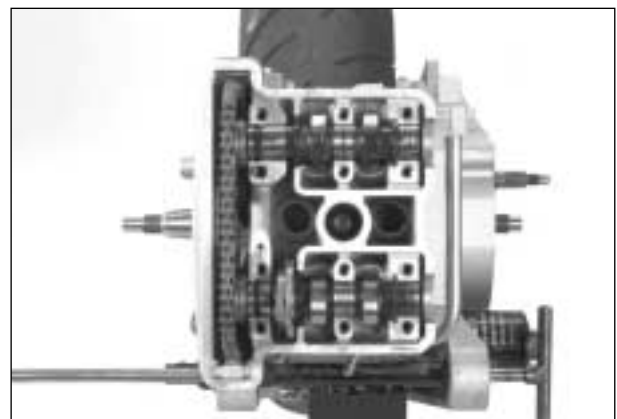

- With the “—” line on the magneto rotor is aligned with the triangle mark on the magneto cover, hold the camshaft steady and lightly pull up the cam chain to remove any slack between the cam chain sprocket and exhaust camshaft sprocket.
- The exhaust camshaft sprocket has an arrow marked “1” ①. Turn the exhaust camshaft so that the arrow is aligned with the gasket surface of the cylinder head. Engage the cam chain with the exhaust camshaft sprocket.
- The other arrow marked “2” ② should now be pointing straight up. Starting from the roller pin that is directly above the arrow marked “2” ②, count out 16 roller pins (from the exhaust camshaft side going towards the intake camshaft side). Engage the 16th roller pin on the cam chain with the arrow marked “3” ③ on the intake sprocket. Refer to the following illustrations.

NOTE

The cam chain should now be on all three sprockets. Be careful not to move the crankshaft until the camshaft housing and cam chain tensioner are secured.

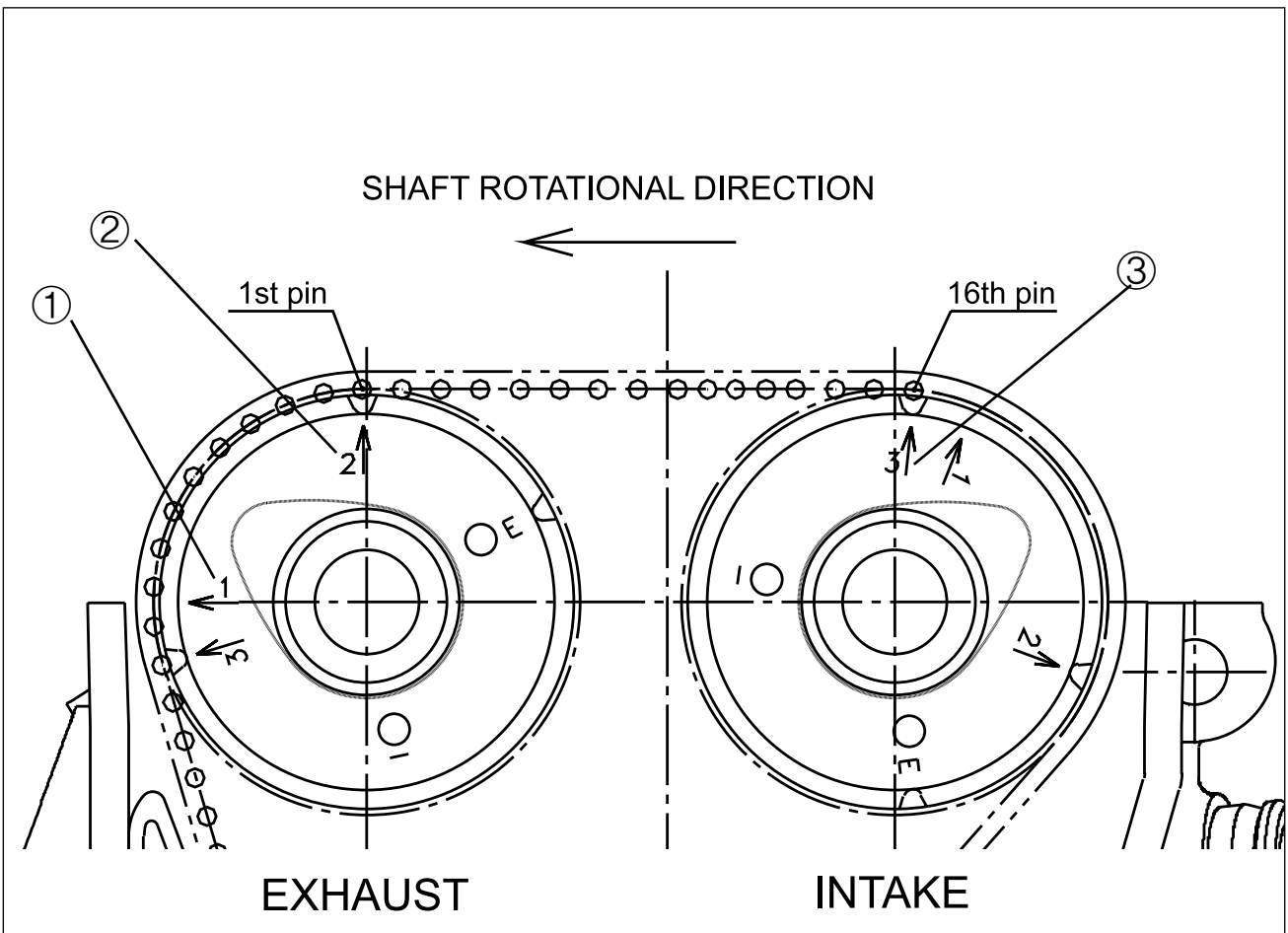
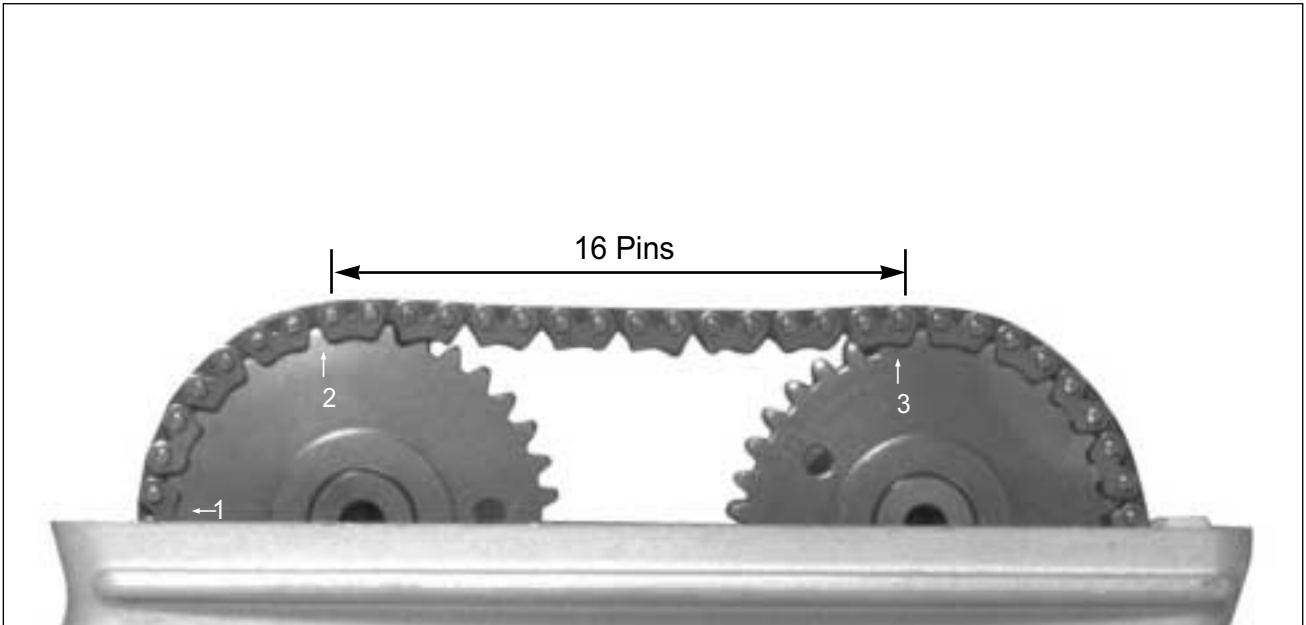

- Install the dowel pins ①.
- Place each camshaft housing and cam chain guide into the correct position.

NOTE

Camshaft housing marked "EX" are for the exhaust side and those marked "IN" are for the intake side.

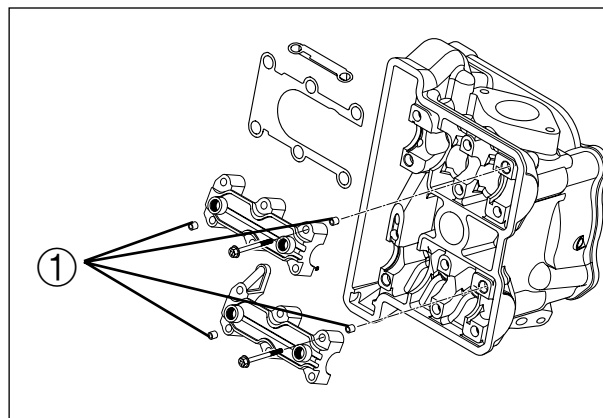

- Install the cam chain guide ② and camshaft housing ③.
- Tighten the camshaft housing bolts to the specified torque.

 **Camshaft housing bolt**
: 8 ~ 12 N · m (0.8 ~ 1.2 kgf · m)

NOTE

When tightening the camshaft housing bolts, the piston position must be at TDC on the compression stroke.

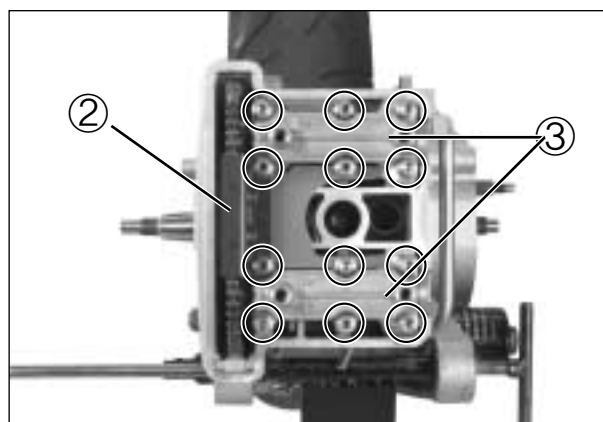
**⊙ CYLINDER HEAD COVER**

- Thoroughly wipe off oil from the fitting surfaces of the cylinder head and cover.
- Apply **BOND "1215"** to the end caps of the cylinder head cover gasket as shown.

 **BOND "1215"**

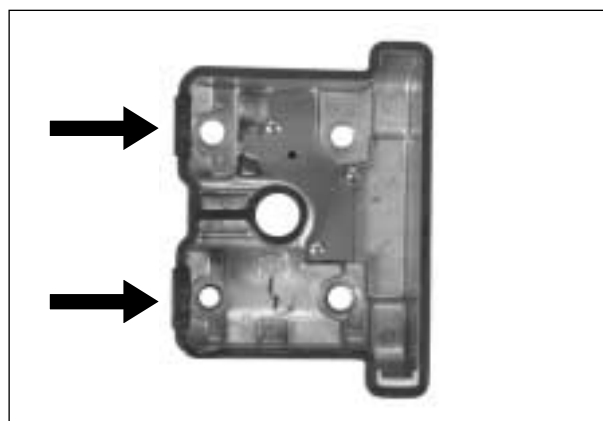

- Apply engine oil to both sides of the washer.
- Lightly tighten the cylinder head cover bolts in diagonal stages, and then tighten them to the specified torque.

 **Cylinder head cover bolt**
: 12 ~ 16 N · m (1.2 ~ 1.6 kgf · m)

⚠ CAUTION

Use a new washers.

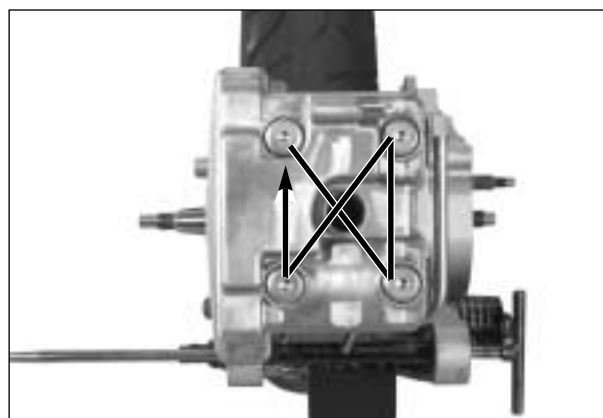

⊙ CAM CHAIN TENSION ADJUSTER

- Apply engine oil to the push rod.
- Unlock the ratchet mechanism and push the push rod ① all the way.

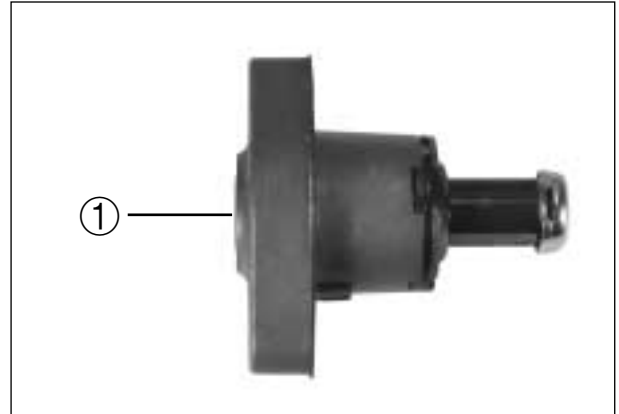

- Install the new gasket and cam chain tension adjuster to the cylinder.
- Tighten the cam chain tension adjuster mounting bolts to the specified torque.

 **Cam chain tension adjuster mounting bolt** : 8 ~ 12 N · m (0.8 ~ 1.2 kgf · m)

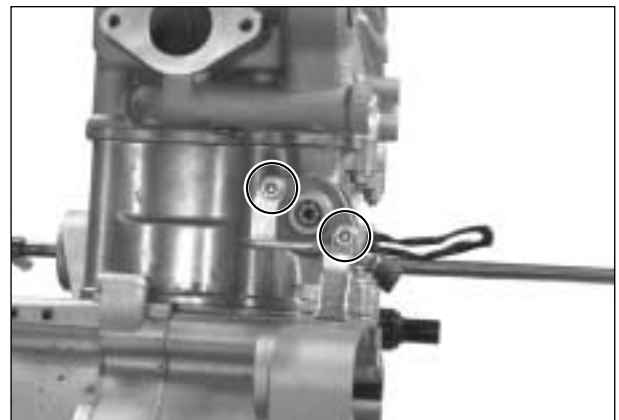

- Tighten the cam chain tension adjuster bolt ② to the specified torque.

 **Cam chain tension adjuster bolt** : 8 ~ 12 N · m (0.8 ~ 1.2 kgf · m)

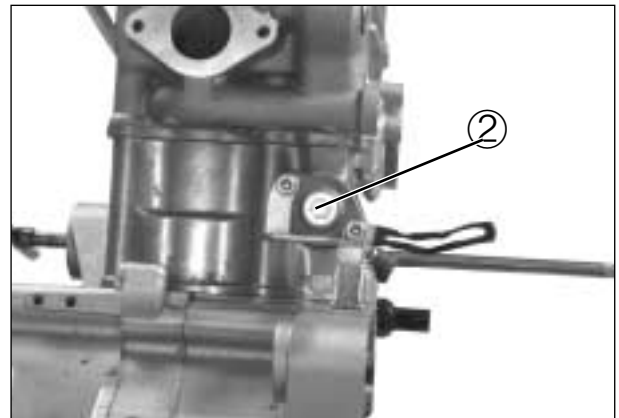

⊙ REAR SUSPENSION ARM

- Install the rear axle nut ③ .

 **Rear axle nut** : 100 ~ 140 N · m (10.0 ~ 14.0 kgf · m)

- Install the rear suspension arm ④ .

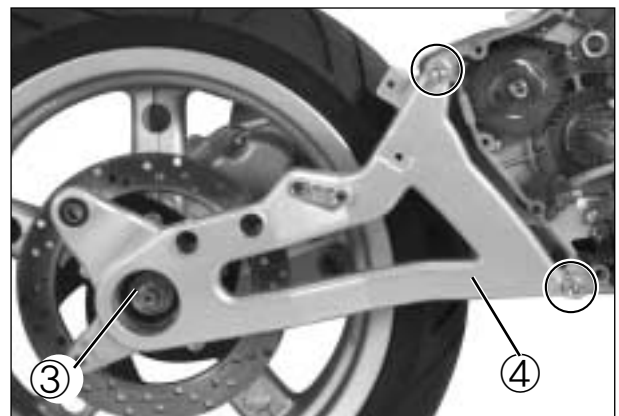

- Install the front rear fender ①, and then tighten the three front rear fender mounting bolts.

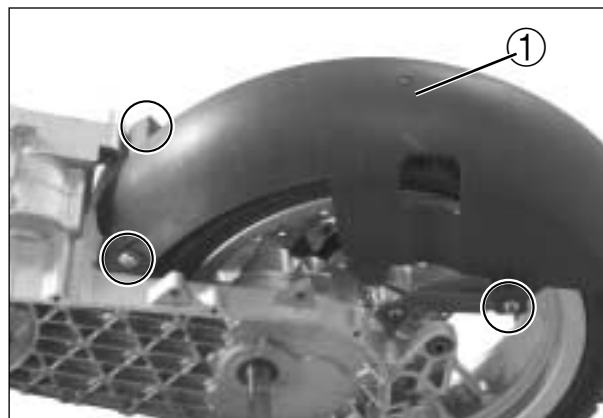

- Install the washer ② and the crank balancer driven gear nut ③. (Only for 『MSB 250』)
- Lock the crankshaft using the special tool and tighten the crank balancer driven gear nut to the specified torque. (Only for 『MSB 250』)

 **Conrod holder : 09910-20115**

 **Crank balancer driven gear nut**

(Only for 『MSB 250』)

: 40 ~ 60 N · m (4.0 ~ 6.0 kgf · m)

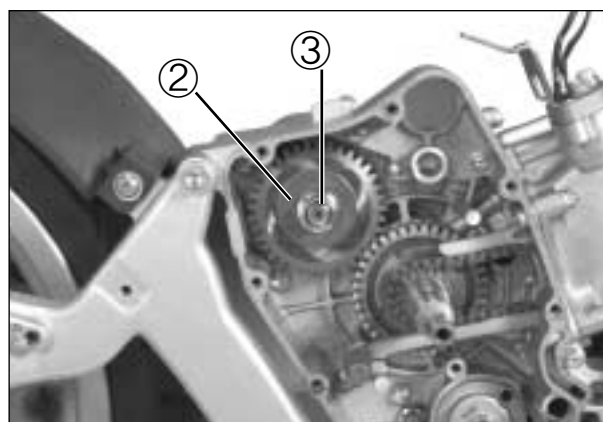

⊙ OIL PUMP

- Install the oil pump ④ and oil pump chain guide ⑤.
- Tighten the oil pump mounting bolts to the specified torque.

 **Oil pump mounting bolt**

: 8 ~ 12 N · m (0.8 ~ 1.2 kgf · m)

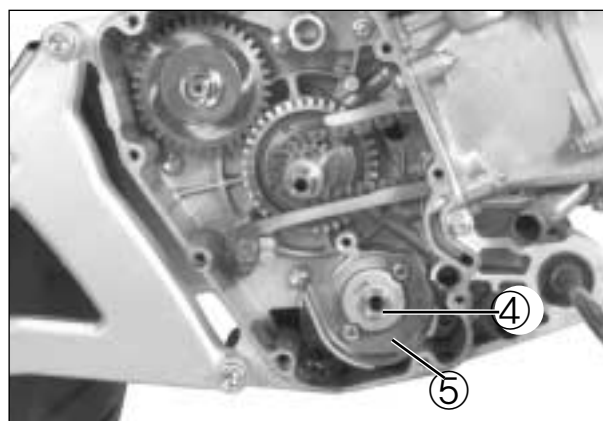

- Install the oil pump sprocket ⑥.
- Install the oil pump sprocket circlip ⑦.
- Engage the oil pump chain ⑧.
- With the other side of the oil pump chain ⑧ engaged with the crankshaft gear.

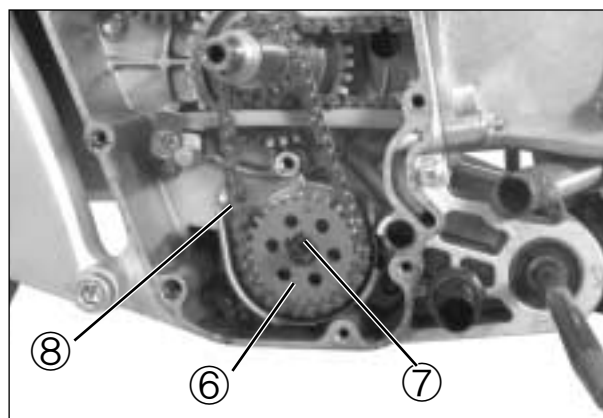

- Install the oil pump cover①.
- Tighten the oil pump cover mounting bolt to the specified torque.

 **Oil pump cover mounting bolt**
: 8 ~ 12 N · m (0.8 ~ 1.2 kgf · m)

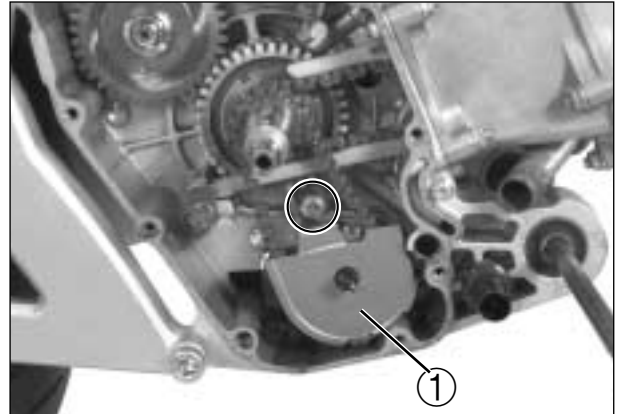

⊙ STARTER CLUTCH GEAR

- Install the starter clutch gear② and the key③.

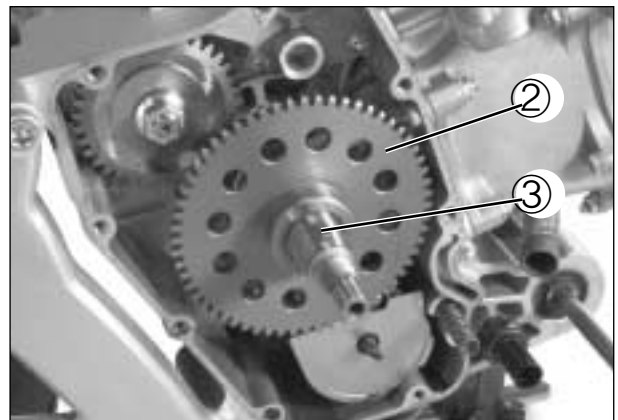

⊙ MAGNETO ROTOR

- Install the magneto rotor④.

NOTE
<i>Make sure to engage the starter clutch with the starter clutch gear.</i>

- Screw the magneto rotor nut⑤.
- Tighten the magneto rotor nut⑤ to the specified torque.

 **Magneto rotor nut**
: 40 ~ 60 N · m (4.0 ~ 6.0 kgf · m)

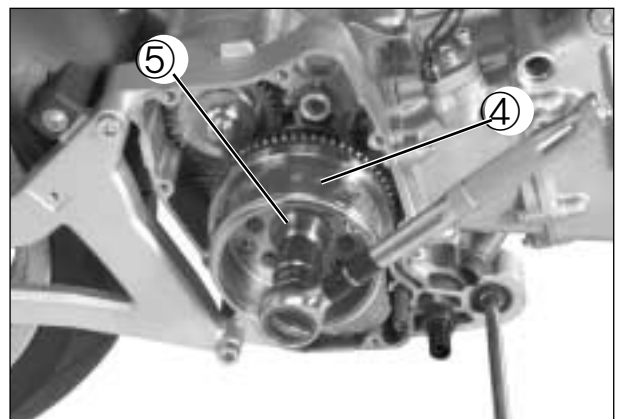

⊙ IDLE GEAR

- Install the starter idle gear shaft and the starter idle gear⑥.

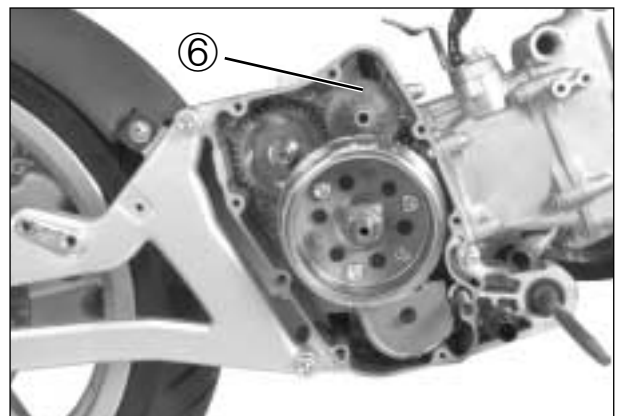

⊙ MAGNETO COVER

- Install the dowel pins and gasket.

⚠ CAUTION

Replace the gasket with a new one.

- Install the magneto cover ①.
- Tighten the magneto cover bolts to the specified torque.

🔧 Magneto cover bolt

: 8 ~ 12 N · m (0.8 ~ 1.2 kgf · m)

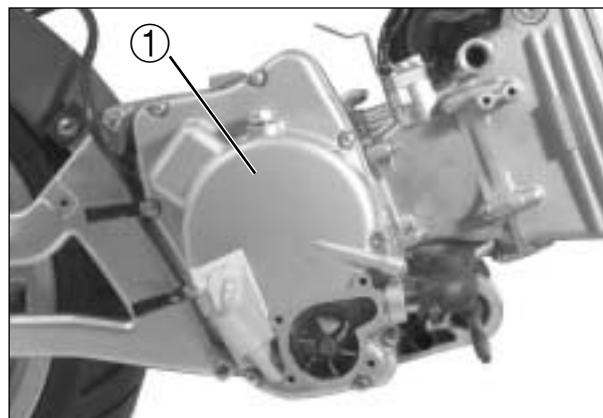

⊙ WATER PUMP

- Apply a small amount of engine oil to the O-ring.
- Install the O-ring on the water pump case.

⚠ CAUTION

Replace the O-ring with new one.

- Install the water pump case ②.
- Tighten the water pump case mounting bolts to the specified torque.

🔧 Water pump case mounting bolt

: 8 ~ 12 N · m (0.8 ~ 1.2 kgf · m)

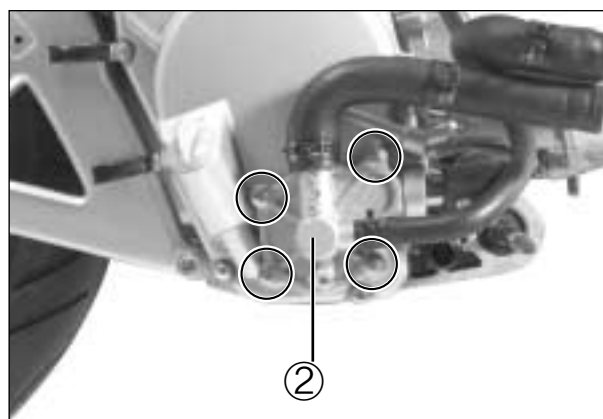

⊙ THERMOSTAT CASE

- Install the thermostat case ③.
- Tighten the thermostat case mounting bolts to the specified torque.

🔧 Thermostat case mounting bolt

: 8 ~ 12 N · m (0.8 ~ 1.2 kgf · m)

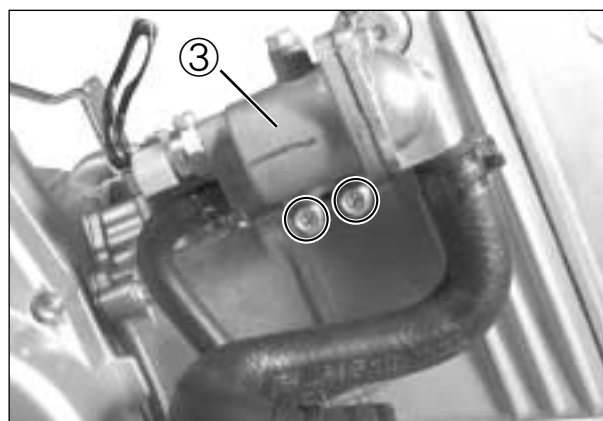

⊙ BELT ROLLER

(Only for 『MS3 250』)

- Install the belt roller ④.
- Tighten the belt roller bolt to the specified torque.

🔧 Belt roller bolt

: 8 ~ 12 N · m (0.8 ~ 1.2 kgf · m)

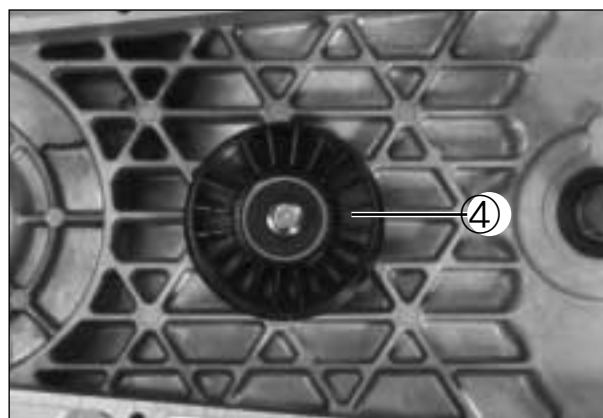

⊙ CLUTCH SHOE / MOVABLE DRIVEN FACE ASSEMBLY

- Insert the drive belt between the driven faces as deep inside as possible while pulling the movable driven face all the way outside to provide the maximum belt clearance.

⚠ CAUTION

- ❖ Position the drive belt so that the arrow **A** points the engine rotating direction.
- ❖ Degrease the drive belt contact surface (pulley face).



- Install the clutch shoe / movable driven face assembly ①.

⚠ CAUTION

Pull the center area of upper and lower belt lines to be close to each other to prevent the belt from expanding.

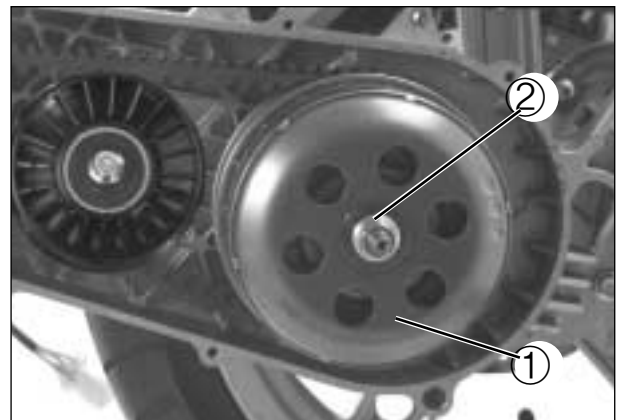

- Tighten the clutch housing nut ② to the specified torque.

⚠ CAUTION

Degrease the inner surface of the clutch housing.

🔧 Clutch housing nut
: 60 N · m (6.0 kgf · m)

⊙ MOVABLE DRIVE FACE ASSEMBLY

- Check that no roller inside the movable drive face is out of position from the slot.
- Install the movable drive face assembly ③.

⚠ CAUTION

- ❖ The assembly work should be carefully performed so as not to allow the roller to dislocate.
- ❖ Degrease the drive belt contact surface (pulley face).

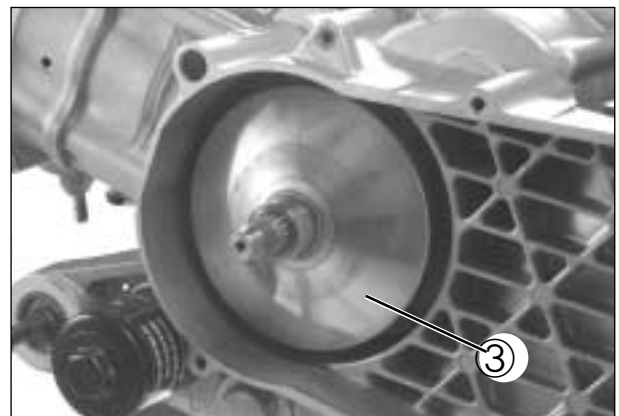

- Install the fixed drive face ① .
- Install the washer ② and fixed drive face nut ③ .

⚠ CAUTION

Check that the fixed drive face is not fouled with grease or other substance and if found, clean and degrease completely.
Check that the parts are properly engaged with the spline.

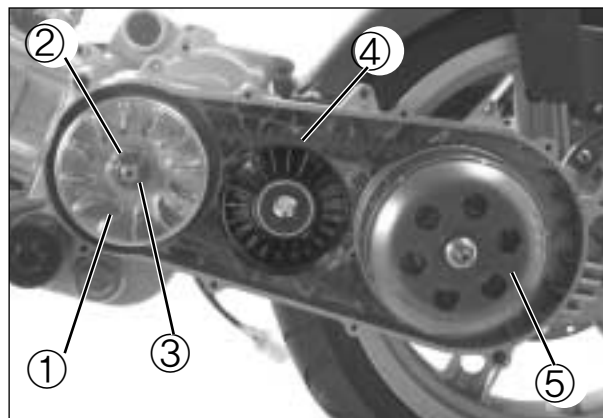

- Tighten the fixed drive face nut ③ to the specified torque.

🔧 Fixed drive face nut

: 50 N · m (5.0 kgf · m)

- To obtain proper contact of the drive V-belt ④ , turn the fixed drive face ① until the fixed drive face and the movable driven face ⑤ can rotate synchronously.

🔧 CLUTCH COVER

- Install the dowel pins and gasket.
- Install the clutch cover ⑥ .
- Tighten the clutch cover bolts to the specified torque.

🔧 Clutch cover bolt

: 8 ~ 12 N · m (0.8 ~ 1.2 kgf · m)

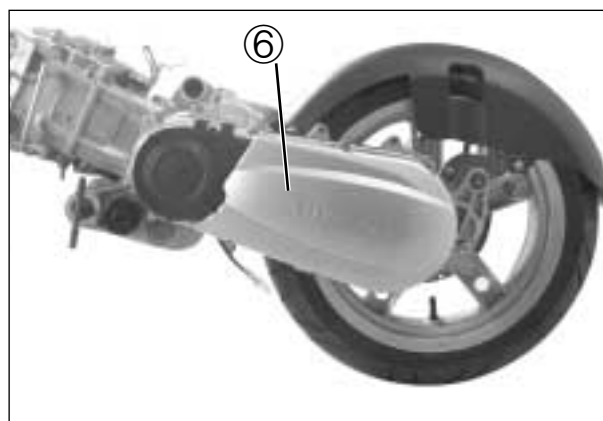

🔧 STARTER MOTOR

- Install the starter motor ⑦ and the oil return tank ⑧ .

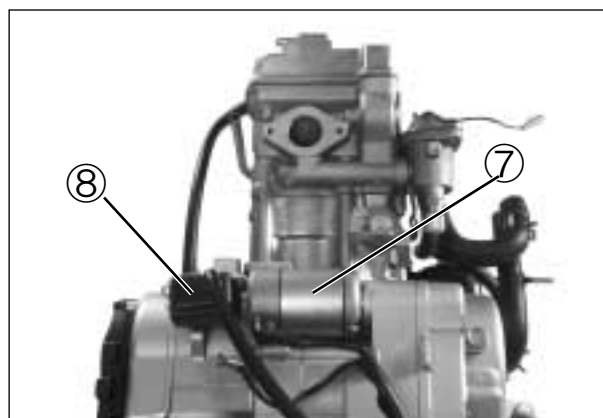

◎ THROTTLE BODY

- Install the insulator① and O-ring.

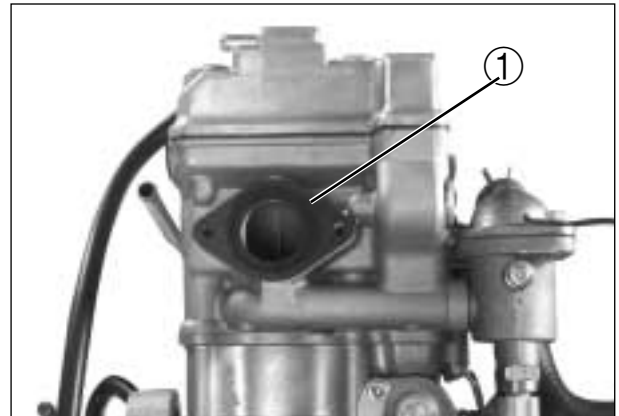

- Install the intake pipe② together with the throttle body③.
- Tighten the intake pipe bolts to the specified torque.

 **Intake pipe bolt**
: 8 ~ 12 N · m (0.8 ~ 1.2 kgf · m)

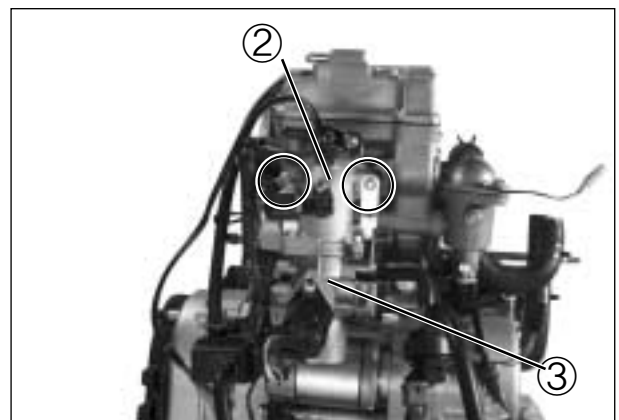

FI SYSTEM DIAGNOSIS

CONTENTS

PRECAUTIONS IN SERVICING	4- 1
FI SYSTEM TECHNICAL FEATURES	4- 5
SELF-DIAGNOSIS FUNCTION	4- 9
FI SYSTEM TROUBLESHOOTING	4-12
CUSTOMER COMPLAINT ANALYSIS	4-12
SELF-DIAGNOSTIC PROCEDURES	4-14
SELF-DIAGNOSIS RESET PROCEDURE	4-14
MALFUNCTION CODE AND DEFECTIVE CONDITION	4-15
"C14" TP SENSOR CIRCUIT MALFUNCTION	4-17
"C15" WT SENSOR CIRCUIT MALFUNCTION	4-20
"C17" IAP SENSOR CIRCUIT MALFUNCTION	4-22
"C21" IAT SENSOR CIRCUIT MALFUNCTION	4-24
"C22" OXYGEN SENSOR CIRCUIT MALFUNCTION	4-26
"C23" TO SENSOR CIRCUIT MALFUNCTION	4-27
"C24" IGNITION COIL MALFUNCTION	4-27
"C27" ISC SOLENOID RANGE ABNORMAL	4-28
"C32" FUEL INJECTOR CIRCUIT MALFUNCTION	4-29
"C37" SAV SOLENOID MALFUNCTION	4-31
"C41" FUEL PUMP RELAY CIRCUIT MALFUNCTION	4-32
"C43" OXYGEN SENSOR HEATER CIRCUIT MALFUNCTION	4-33
SENSORS	4-34

PRECAUTIONS IN SERVICING

When handling the component parts or servicing the FI system, observe the following points for the safety of the system.

⊙ ELECTRICAL PARTS

▣ CONNECTOR / COUPLER

- When connecting a connector, be sure to push it in until a click is felt.
- With a lock type coupler, be sure to release the lock when disconnecting, and push it in fully till the works when connecting it.
- When disconnecting the coupler, be sure to hold the coupler body and do not pull the lead wires.
- Inspect each terminal on the connector / coupler for looseness or bending.
- Inspect each terminal for corrosion and contamination.
The terminals must be clean and free of any foreign material which could impede proper terminal contact.
- Inspect each lead wire circuit for poor connection by shaking it by hand lightly. If any abnormal condition is found, repair or replace.
- When taking measurements at electrical connectors using a tester probe, be sure to insert the probe from the wire harness side (backside) of the connector / coupler.

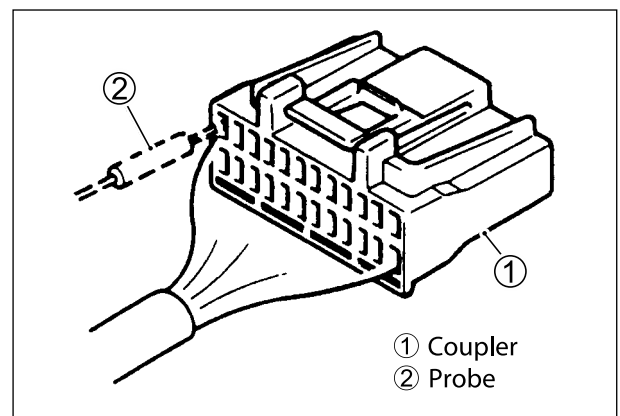
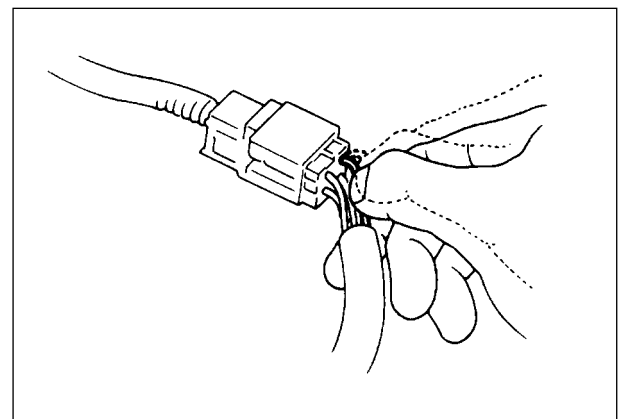
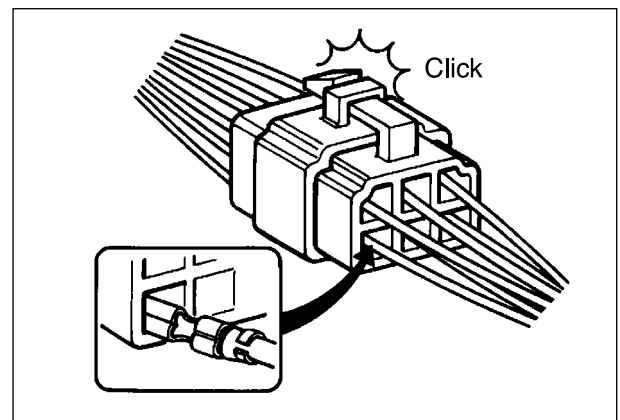
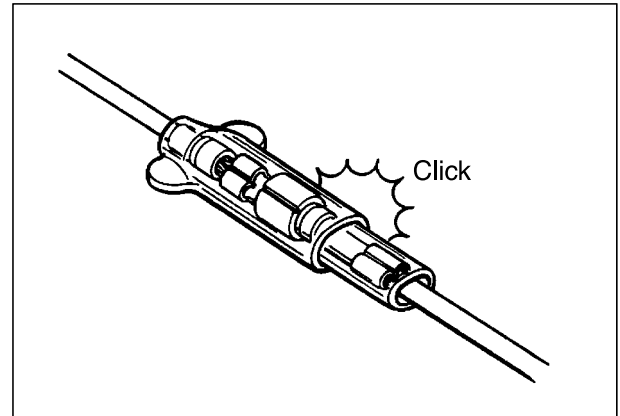

- When connecting meter probe from the terminal side of the coupler (connection from harness side not being possible), use extra care not to force and cause the male terminal to bend or the female terminal to open.

Connect the probe as shown to avoid opening of female terminal.

Never push in the probe where male terminal is supposed to fit.

- Check the male connector for bend and female connector for excessive opening. Also check the coupler for locking (looseness), corrosion, dust, etc.

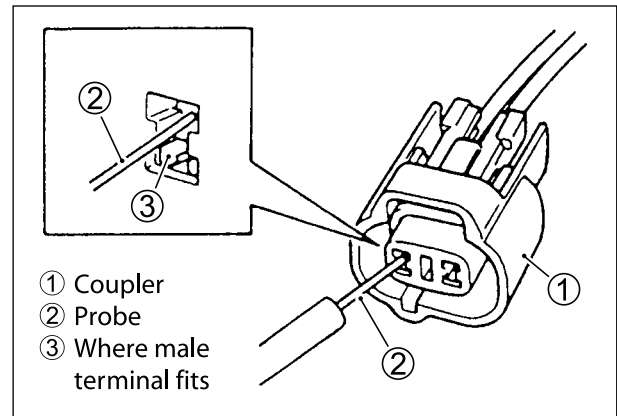

⦿ FUSE

- When a fuse blows, always investigate the cause to correct it and then replace the fuse.
- Do not use a fuse of a different capacity.
- Do not use wire or any other substitute for the fuse.

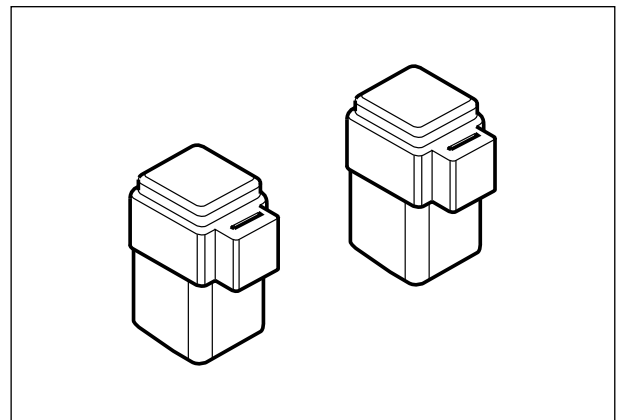

⦿ ECU / VARIOUS SENSORS

- Since each component is a high-precision part, great care should be taken not to apply any sharp impacts during removal and installation.

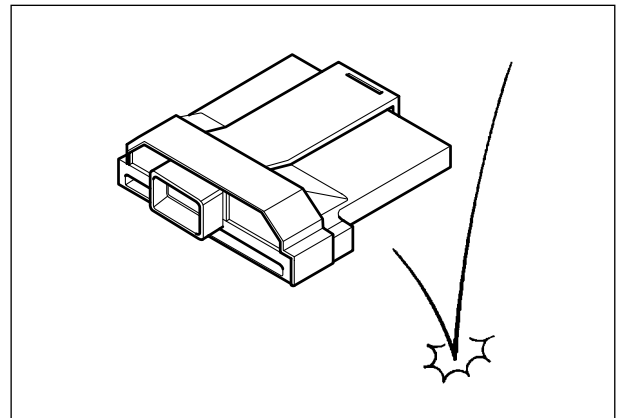

- Be careful not to touch the electrical terminals of the ECU.
The static electricity from your body may damage this part.

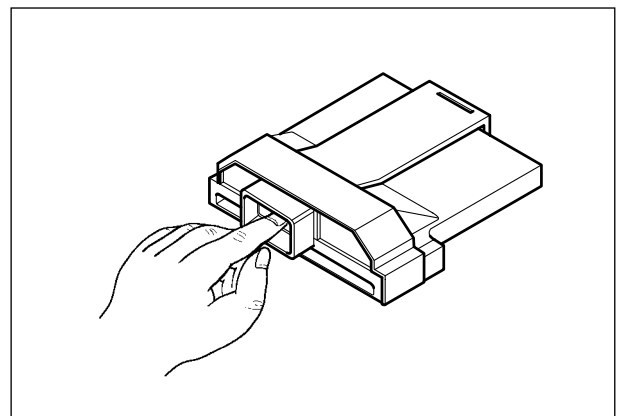

4-3 FI SYSTEM DIAGNOSIS

- When disconnecting and connecting the ECU, make sure to turn "⊗"(OFF) the ignition switch, or electronic parts may get damaged.

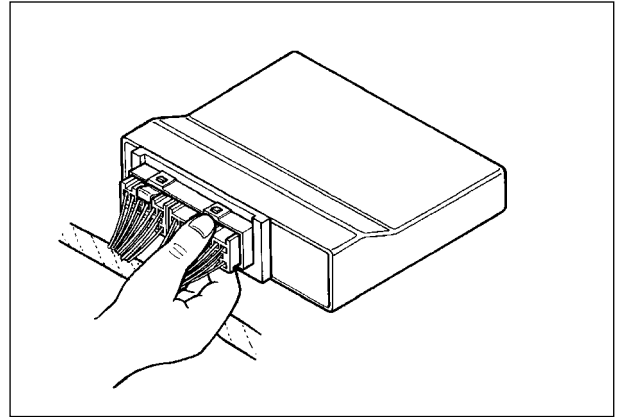

- Battery connection in reverse polarity is strictly prohibited. Such a wrong connection will damage the components of the FI system instantly when reverse power is applied.

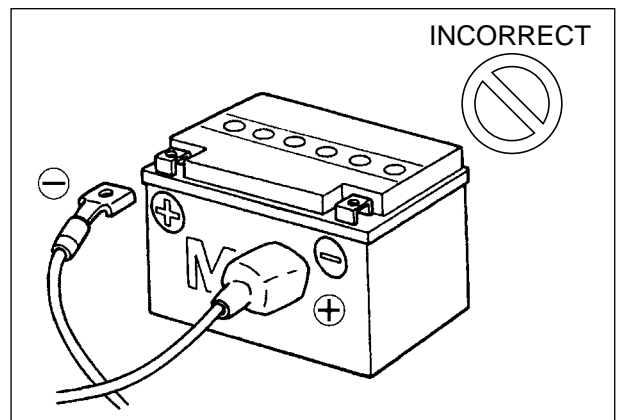

- Removing any battery terminal of a running engine is strictly prohibited. The moment such removal is made, damaging counter electromotive force will be applied to the ECU which may result in serious damage.

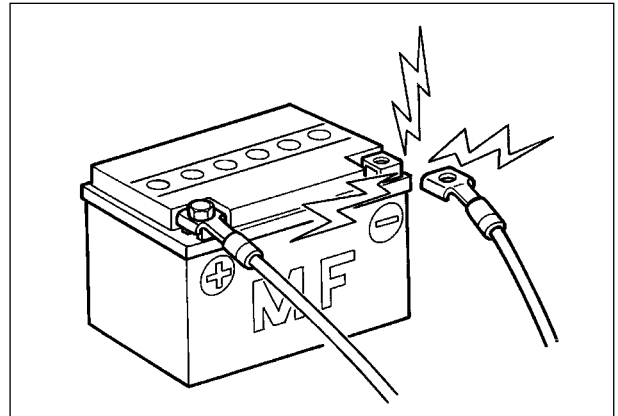

- Before measuring voltage at each terminal, check to make sure that battery voltage is 11V or higher. Terminal voltage check at low battery voltage will lead to erroneous diagnosis.

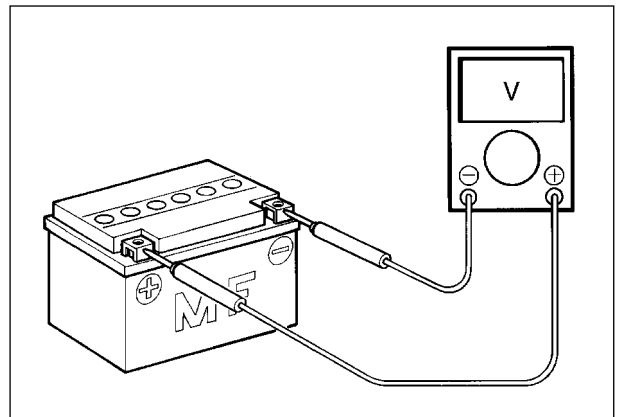

- Never connect any tester (voltmeter, ohmmeter, or whatever) to the ECU when its coupler is disconnected.
Otherwise, damage to ECU may result.
- Never connect an ohmmeter to the ECU with its coupler connected. If attempted, damage to ECU or sensors may result.
- Be sure to use a specified voltmeter / ohmmeter.
Otherwise, accurate measurements may not be obtained and personal injury may result.

⊙ USING TESTERS

- Use well-charged batteries in the tester.
- Be sure to set the tester to the correct testing range.

▣ USING THE TESTER

- Incorrectly connecting the ⊕ and ⊖ probes may cause the inside of the tester to burnout.
- If the voltage and current are not known, make measurements using the highest range.
- Check that no voltage is applied before making the measurement. If voltage is applied the tester may be damaged.
- After using the tester, turn the power off.

FI SYSTEM TECHNICAL FEATURES

◎ INJECTION TIME (INJECTION VOLUME)

The factors to determine the injection time include the basic fuel injection time, which is calculated on the basis of intake air pressure, engine speed and throttle opening angle, and various compensations.

These compensations are determined according to the signals from various sensors that detect the engine and driving conditions.

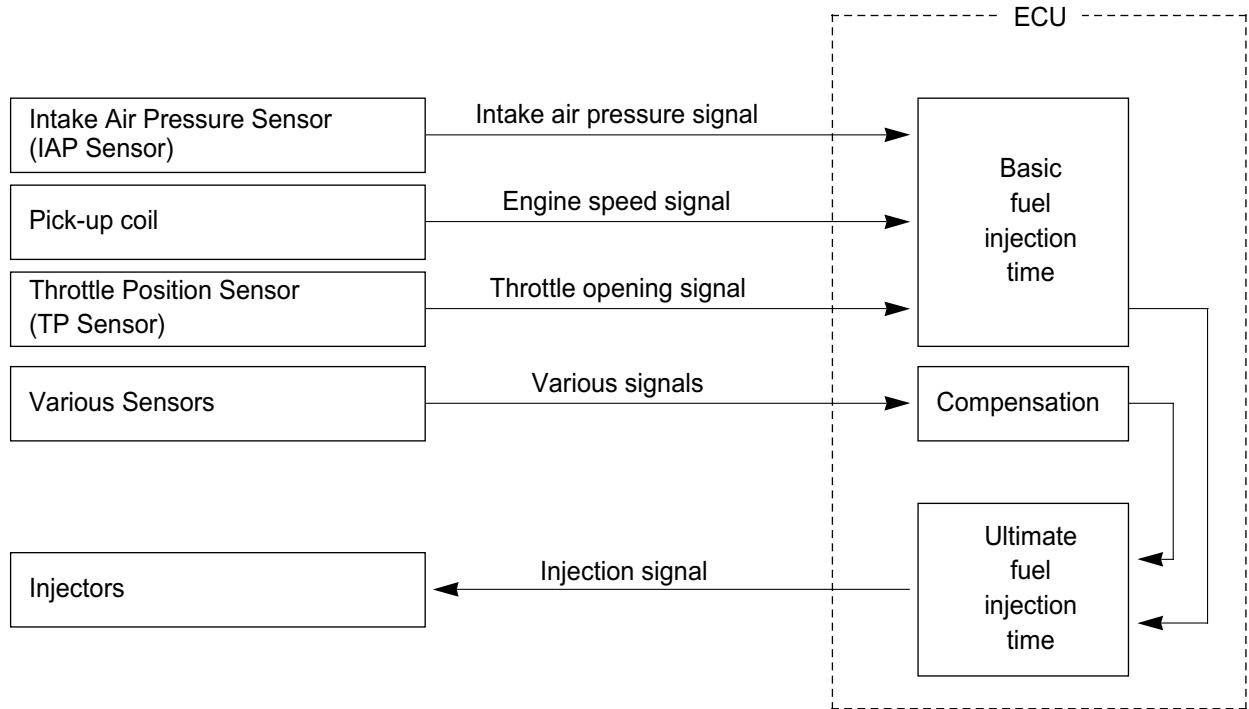

◎ COMPENSATION OF INJECTION TIME (VOLUME)

The following different signals are output from the respective sensors for compensation of the fuel injection time (volume).

SIGNAL	DESCRIPTION
WATER COOLANT TEMPERATURE SENSOR SIGNAL	When engine coolant temperature is low, injection time (volume) is increased.
INTAKE AIR TEMPERATURE SENSOR SIGNAL	When intake air temperature is low, injection time (volume) is increased.
BATTERY VOLTAGE SIGNAL	ECU operates on the battery voltage and at the same time, it monitors the voltage signal for compensation of the fuel injection time (volume). A longer injection time is needed to adjust injection volume in the case of low voltage.
ENGINE RPM SIGNAL	At high speed, the injection time (volume) is increased.
STARTING SIGNAL	When starting engine, additional fuel is injected during cranking engine.
ACCELERATION SIGNAL / DECELERATION SIGNAL	During acceleration, the fuel injection time (volume) is increased in accordance with the throttle opening speed and engine rpm. During deceleration, the fuel injection time (volume) is decreased.

◎ INJECTION STOP CONTROL

SIGNAL	DESCRIPTION
TIP OVER SENSOR SIGNAL (FUEL CUT-OFF)	When the motorcycle tips over, the tip over sensor sends a signal to the ECU. Then, this signal cuts OFF current supplied to the fuel pump, fuel injector and ignition coil.
OVER-REV. LIMITER SIGNAL	The fuel injectors stop operation when engine rpm reaches rev. limit rpm.

◎ FI SYSTEM PARTS LOCATION

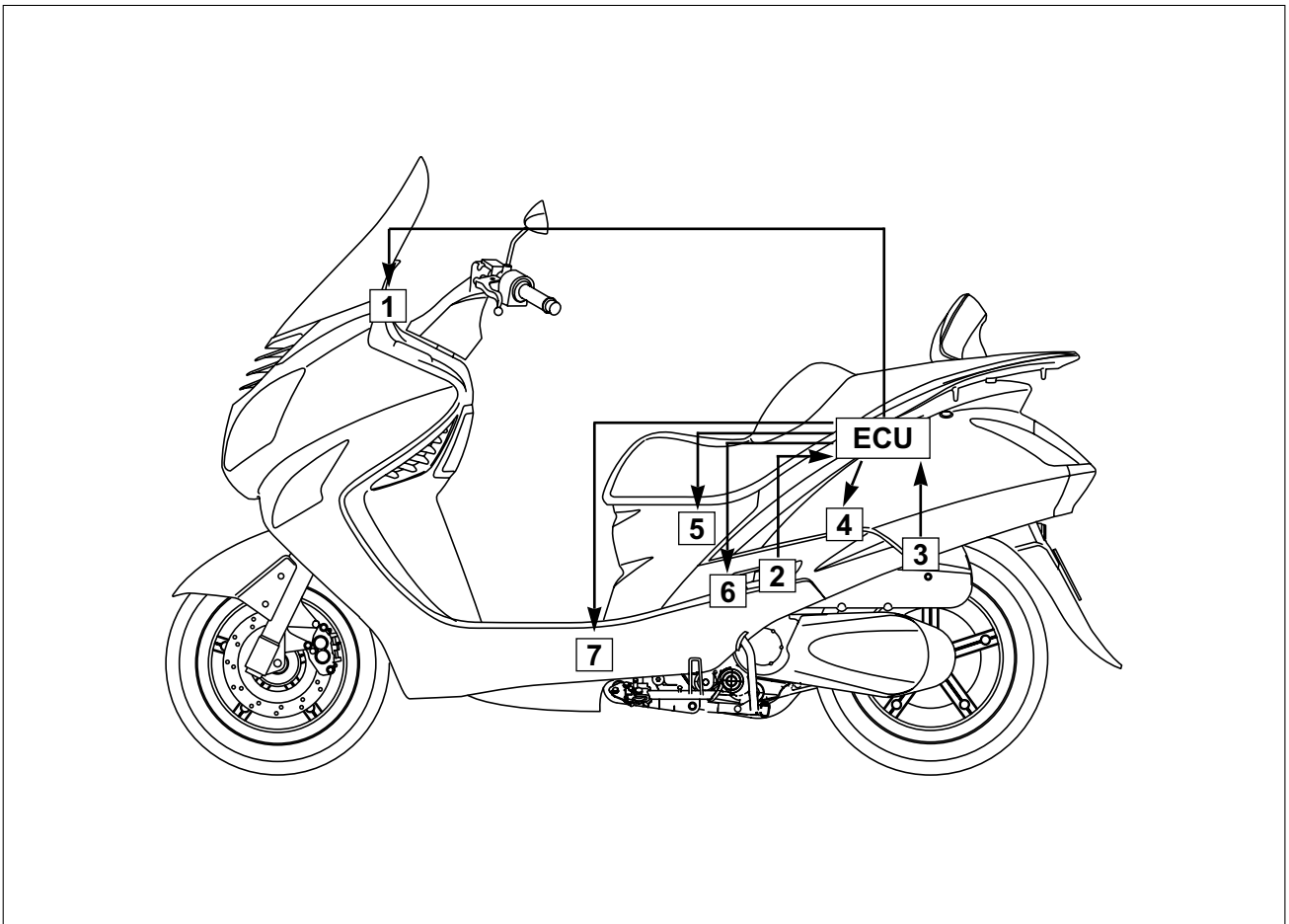

① Speedometer

② TP sensor

③ IAT sensor

④ ISC solenoid

⑤ Fuel injector

⑥ Ignition coil

⑦ Fuel pump relay

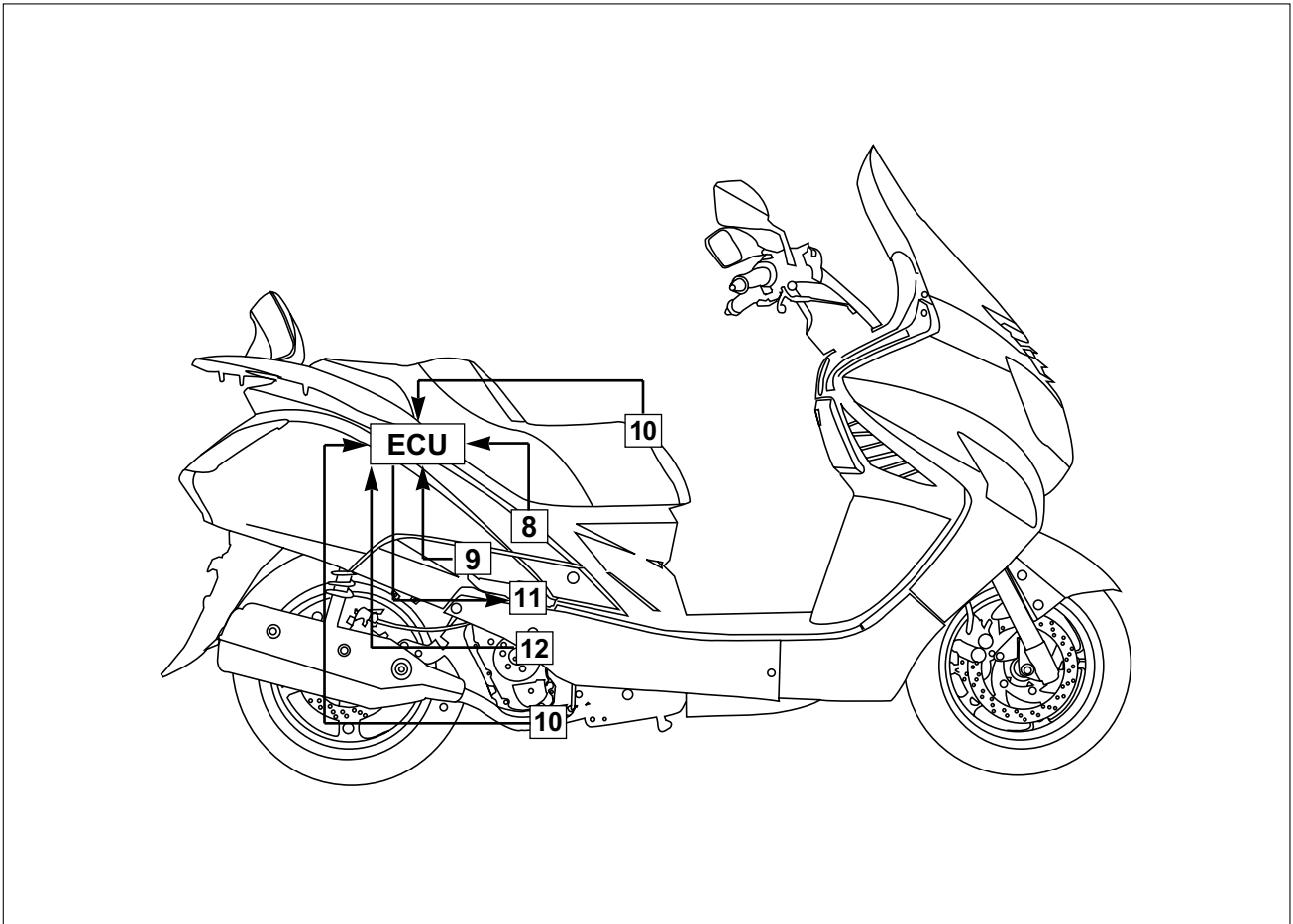

- ⑧ IAP sensor
- ⑨ WT sensor
- ⑩ TO sensor

- ⑪ SAV solenoid
- ⑫ Pick-up coil
- ⑬ Oxygen sensor

SELF-DIAGNOSIS FUNCTION

The self-diagnosis function is incorporated in the ECU. The function has two modes, "USER MODE" and "DEALER MODE". The user can only be notified by the "FI" check lamp "FI" ①. To check the function of the individual FI system devices, the dealer mode is prepared. In this check, the special tool is necessary to read the code of the malfunction items.

⊙ USER MODE

The "FI" check lamp "FI" ① comes on for about three seconds whenever the ignition switch is set to "ON" position with the engine stopped as a test of the injection system operation. The check lamp must go off after three seconds.

If the check lamp comes on during normal engine operation, it means that the fuel injection system is not operating correctly.

When this is the case, inspect the fuel injection system to refer to "Dealer mode".

MSB 250

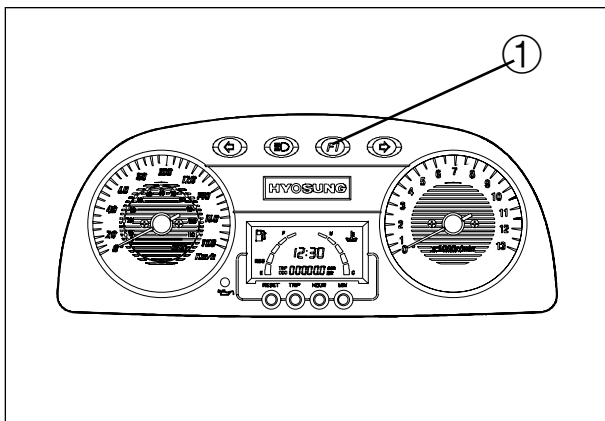

MSB 125

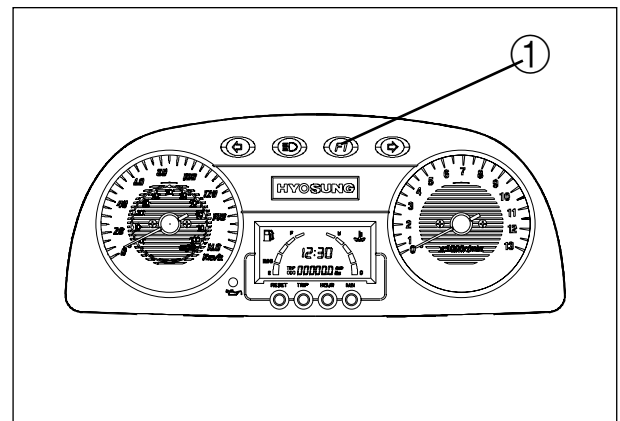

⊙ DEALER MODE

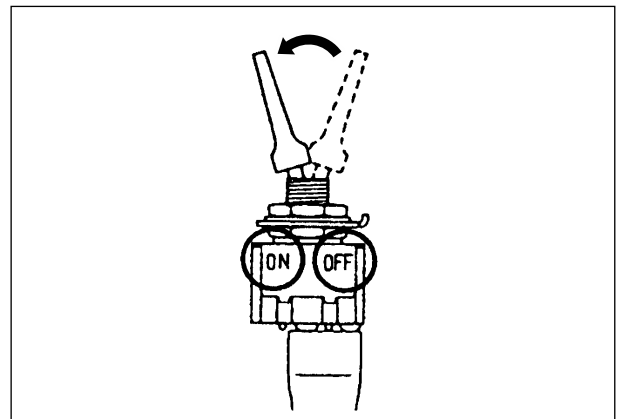
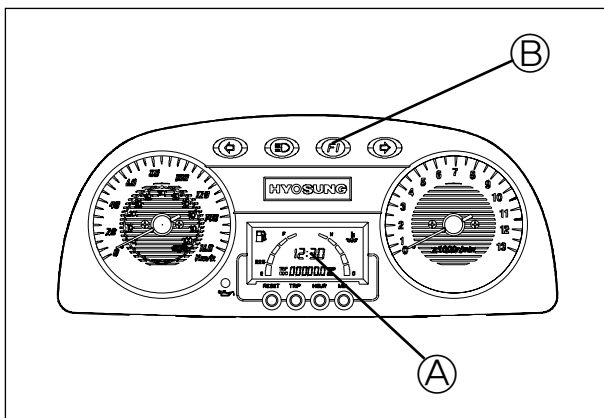
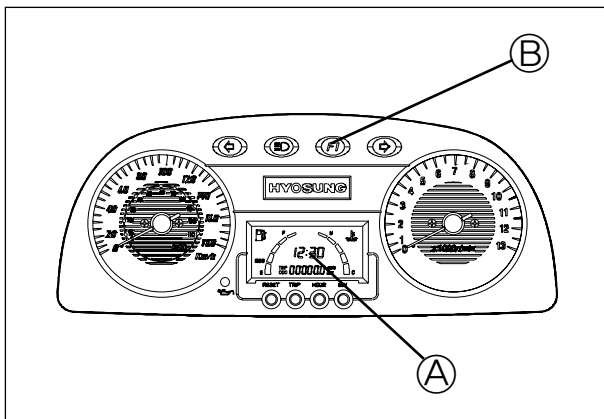

The defective function is memorized in the computer. Use the special tool's coupler to connect to the dealer mode coupler. (Refer to page 4-14) The memorized malfunction code is displayed on LCD (DISPLAY) panel. Malfunction means that the ECU does not receive signal from the devices. These affected devices are indicated in the code form.

 Mode select switch : 09900-27000



CAUTION

- ❖ Do not disconnect the ECU lead wire couplers, before checking the malfunction code, or the malfunction code memory is erased and the malfunction code can not be checked.
- ❖ Confirm the malfunction code after turn the ignition switch “⊙”(ON) position or cranking the engine for few seconds.

MALFUNCTION	LCD (DISPLAY) INDICATION 	INDICATION MODE 
“NO”	Clock	“FI” check lamp goes off.
“YES”	C**code is indicated from small numeral to large one.	“FI” check lamp comes on continually.

4-11 FI SYSTEM DIAGNOSIS

CODE	MALFUNCTION PART	REMARKS
C14	Throttle position sensor (TPS)	
C15	Water temperature sensor (WTS)	
C17	Intake air pressure sensor (IAPS)	
C21	Intake air temperature sensor (IATS)	
C22	Oxygen sensor (O ₂ S)	
C23	Tip over sensor (TOS)	
C24	IG coil	
C27	Idle speed control solenoid (ISC solenoid)	
C32	Fuel injector	
C37	Secondary air valve solenoid (SAV solenoid)	
C41	Fuel pump relay	
C43	Oxygen sensor heater (O ₂ S heater)	

In the LCD (DISPLAY) panel, the malfunction code is indicated from small code to large code.

FI SYSTEM TROUBLESHOOTING

CUSTOMER COMPLAINT ANALYSIS

Record details of the problem (failure, complaint) and how it occurred as described by the customer. For this purpose, use of such an inspection form will facilitate collecting information to the point required for proper analysis and diagnosis.

EXAMPLE : CUSTOMER PROBLEM INSPECTION FORM

User name :	Model :	VIN :	
Date of issue :	Date Reg.	Date of problem :	Mileage :

"FI" Check lamp	<input type="checkbox"/> Always ON <input type="checkbox"/> Sometimes ON <input type="checkbox"/> Always OFF <input type="checkbox"/> Good condition
Malfunction display / code (LCD)	<input type="checkbox"/> No code <input type="checkbox"/> Malfunction code ()

PROBLEM SYMPTOMS

<input type="checkbox"/> Difficult Starting <input type="checkbox"/> No cranking <input type="checkbox"/> No initial combustion <input type="checkbox"/> No combustion <input type="checkbox"/> Poor starting at (<input type="checkbox"/> cold <input type="checkbox"/> warm <input type="checkbox"/> always) <input type="checkbox"/> Other _____	<input type="checkbox"/> Poor Driveability <input type="checkbox"/> Hesitation on acceleration <input type="checkbox"/> Back fire / <input type="checkbox"/> After fire <input type="checkbox"/> Lack of power <input type="checkbox"/> Surging <input type="checkbox"/> Abnormal knocking <input type="checkbox"/> Engine rpm jumps briefly <input type="checkbox"/> Other _____
<input type="checkbox"/> Poor Idling <input type="checkbox"/> Poor fast idle <input type="checkbox"/> Abnormal idling speed (<input type="checkbox"/> High <input type="checkbox"/> Low) (rpm) <input type="checkbox"/> Unstable <input type="checkbox"/> Hunting (rpm. to rpm) <input type="checkbox"/> Other _____	<input type="checkbox"/> Engine Stall when <input type="checkbox"/> Immediately after start <input type="checkbox"/> Throttle valve is opened <input type="checkbox"/> Throttle valve is closed <input type="checkbox"/> Load is applied <input type="checkbox"/> Other _____
<input type="checkbox"/> OTHERS :	

4-13 FI SYSTEM DIAGNOSIS

MOTORCYCLE / ENVIRONMENTAL CONDITION WHEN PROBLEM OCCURS	
Environmental condition	
Weather	<input type="checkbox"/> Fair <input type="checkbox"/> Cloudy <input type="checkbox"/> Rain <input type="checkbox"/> Snow <input type="checkbox"/> Always <input type="checkbox"/> Other
Temperature	<input type="checkbox"/> Hot <input type="checkbox"/> Warm <input type="checkbox"/> Cool <input type="checkbox"/> Cold (°F / °C) <input type="checkbox"/> Always
Frequency	<input type="checkbox"/> Always <input type="checkbox"/> Sometimes (times / day, month) <input type="checkbox"/> Only once
	<input type="checkbox"/> Under certain condition
Road	<input type="checkbox"/> Urban <input type="checkbox"/> Suburb <input type="checkbox"/> Highway <input type="checkbox"/> Mountainous (<input type="checkbox"/> Uphill <input type="checkbox"/> Downhill)
	<input type="checkbox"/> Tarmacadam <input type="checkbox"/> Gravel <input type="checkbox"/> Other
Motorcycle condition	
Engine condition	<input type="checkbox"/> Cold <input type="checkbox"/> Warming up phase <input type="checkbox"/> Warmed up <input type="checkbox"/> Always <input type="checkbox"/> Other at starting
	<input type="checkbox"/> Immediately after start <input type="checkbox"/> Racing without load <input type="checkbox"/> Engine speed (rpm)
Motorcycle condition	During driving : <input type="checkbox"/> Constant speed <input type="checkbox"/> Accelerating <input type="checkbox"/> Decelerating
	<input type="checkbox"/> Right hand corner <input type="checkbox"/> Left hand corner <input type="checkbox"/> At stop
	<input type="checkbox"/> Motorcycle speed when problem occurs (km/h, Mile/h)
	<input type="checkbox"/> Other _____

NOTE

The above form is a standard sample. It should be modified according to conditions characteristic of each market.

SELF-DIAGNOSTIC PROCEDURES

Don't disconnect couplers from ECU, battery cable from battery, ECU ground wire harness from engine or main fuse before confirming malfunction code (self-diagnostic trouble code) stored in memory. Such disconnection will erase memorized information in ECU memory.

Malfunction code stored in ECU memory can be checked by the special tool.

To check malfunction code, read SELF-DIAGNOSIS FUNCTION "DEALER MODE" (Refer to page 4-10,11) carefully to have good understanding as to what functions are available and how to use it.

Be sure to read "PRECAUTIONS for Electrical Circuit Service" (Refer to page 4-1) before inspection and observe what is written there.

- Lift and support the side cover with the side cover stay. (Refer to page 2-2)
- Connect the special tool to the dealer mode coupler at the wiring harness, and the ignition switch is set to "⊙" (ON) position.
- Turn the special tool's switch "ON" position and check the malfunction code to determine the malfunction part.

 **Mode select switch : 09900-27000**

NOTE

The dealer mode coupler is located under the seat.

SELF-DIAGNOSIS RESET PROCEDURE

- After repairing the trouble, turn the ignition switch "⊗" (OFF) position and turn "⊙" (ON) position again.
- If clock ① indicates, the malfunction codes are cleared.
- Disconnect the special tool from the dealer mode coupler.

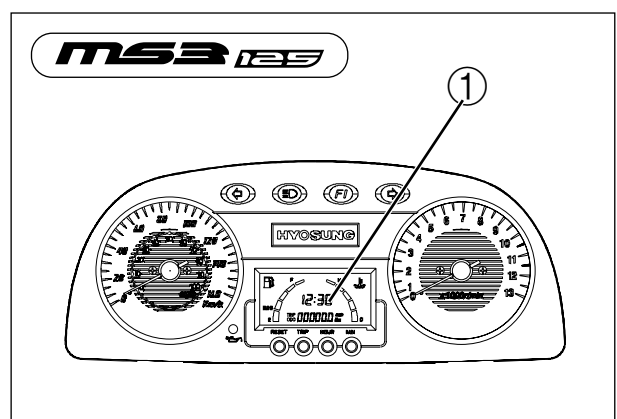
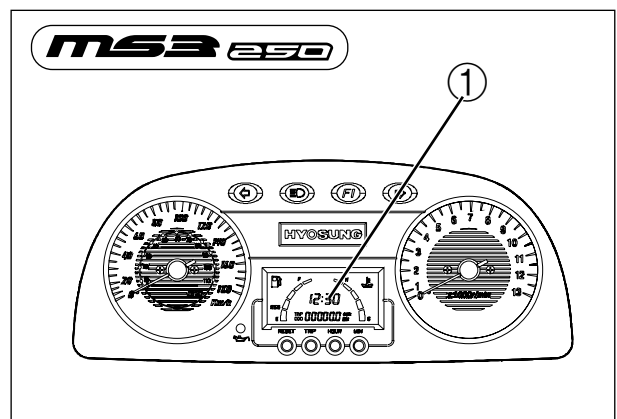
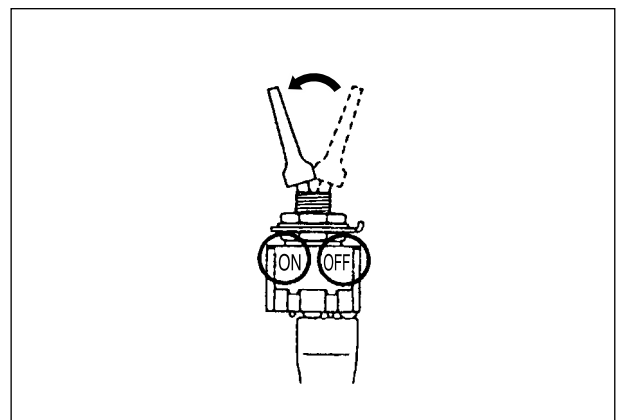

MALFUNCTION CODE AND DEFECTIVE CONDITION

MALFUNCTION CODE	DETECTED ITEM	DETECTED FAILURE CONDITION
		CHECK FOR
C14	Throttle position sensor (TPS)	The sensor should produce following voltage. $0.1 \text{ V} \leq \text{sensor voltage} < 4.8 \text{ V}$ Without the above range for 4 sec. and more, C14 is indicated.
		Throttle position sensor, lead wire / coupler connection.
C15	Water temperature sensor (WTS)	The sensor voltage should be the following. $0.1 \text{ V} \leq \text{sensor voltage} < 4.6 \text{ V}$ Without the above range for 4 sec. and more, C15 is indicated.
		Water temperature sensor, lead wire / coupler connection.
C17	Intake air pressure sensor (IAPS)	The sensor should produce following voltage. $0.1 \text{ V} \leq \text{sensor voltage} \leq 4.8 \text{ V}$ Without the above range for 4 sec. and more, C17 is indicated.
		Intake air pressure sensor, lead wire / coupler connection.
C21	Intake air temperature sensor (IATS)	The sensor voltage should be the following. $0.1 \text{ V} \leq \text{sensor voltage} < 4.6 \text{ V}$ Without the above range for 4 sec. and more, C21 is indicated.
		Intake air temperature sensor, lead wire / coupler connection.
C22	Oxygen sensor (O ₂ S)	The oxygen sensor signal is input in ECU since then 120 sec after the engine run. When this is the case, ECU not receive the signal, C22 is indicated.
		Oxygen sensor, lead wire / coupler connection.
C23	Tip over sensor (TOS)	The sensor voltage should be the following for more than 2 sec. after ignition switch turns "ⓘ" (ON) position. $4.5 \text{ V} \leq \text{sensor voltage} \leq 5.5 \text{ V}$ Without the above value for 2 sec. and more, C23 is indicated.
		Tip over sensor, lead wire / coupler connection.

MALFUNCTION CODE	DETECTED ITEM	DETECTED FAILURE CONDITION
		CHECK FOR
C24	Ignition coil (IG coil)	When the IC of the ECU electric current gets 6A and more, C24 is indicated.
		Ignition coil, wiring / coupler connection, power supply from the battery.
C27	Idle speed control solenoid (ISC solenoid)	The idle speed control solenoid step should be the following. O step \leq solenoid step \leq 100 step Without the above range, C27 is indicated.
		Idle speed control solenoid, lead wire / coupler connection.
C32	Fuel injector	The fuel injector not comes in voltage from the battery, C32 is indicated.
		Injector, wiring / coupler connection, power supply to the injector.
C37	Secondary air valve solenoid (SAV solenoid)	When the secondary air valve solenoid voltage is not input in ECU, C37 is indicated.
		Secondary air valve solenoid, lead wire / coupler connection.
C41	Fuel pump relay	No voltage is applied to the injector for 3 sec. after the contact of fuel pump relay is turned "ON" position. Or voltage is applied to the injector, when the contact of fuel pump is "OFF" position.
		Fuel pump relay, connecting lead wire, power source to fuel pump relay, fuel injector.
C43	Oxygen sensor heater (O ₂ S heater)	The oxygen sensor heater signal is not input in ECU.
		Oxygen sensor heater, lead wire / coupler connection.

“C14” TP SENSOR CIRCUIT MALFUNCTION

DETECTED CONDITION	POSSIBLE CAUSE
Output voltage is out of the specified range. $0.1\text{ V} \leq \text{Sensor voltage} < 4.8\text{ V}$	<ul style="list-style-type: none"> ● TP sensor circuit open or short. ● TP sensor malfunction. ● ECU malfunction.

▣ INSPECTION

◆ Step 1

- 1) Turn the ignition switch “⊗” (OFF) position.
- 2) Check the TP sensor coupler for loose or poor contacts.
 If OK, then measure the TP sensor input voltage.
- 3) Disconnect the TP sensor coupler ①.

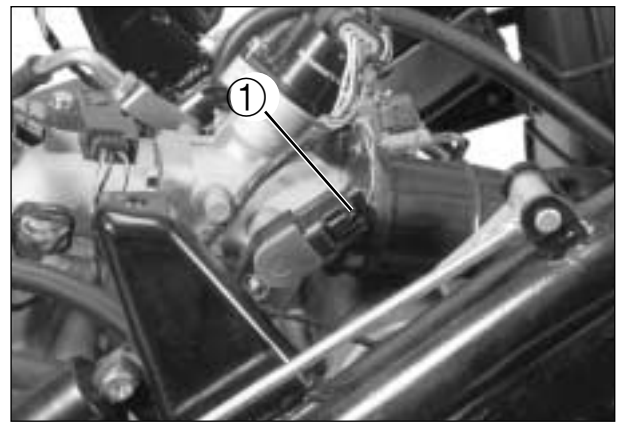

- 4) Turn the ignition switch “⊙” (ON) position.
- 5) Measure the voltage at the OB wire and ground.
- 6) If OK, then measure the voltage at the OB wire and BW wire.

TP sensor input voltage	4.5 ~ 5.5 V (⊕ OB — ⊖ Ground) (⊕ OB — ⊖ BW)
--------------------------------	---

Tester knob indication : Voltage (---)

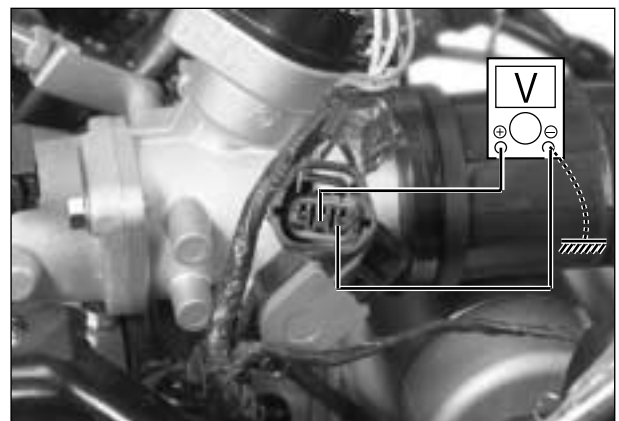

Is the voltage OK?

YES	Go to Step 2.
NO	<ul style="list-style-type: none"> ● Loose or poor contacts on the ECU coupler. ● Open or short circuit in the OB wire or BW wire.



◆ Step 2

- 1) Lift and support the side cover with the side cover stay. (Refer to page 2-2)
- 2) Turn the ignition switch “” (OFF) position.
- 3) Disconnect the TP sensor coupler.
- 4) Check the continuity between (A) and ground.

TP sensor continuity	$\infty \Omega$ (Infinity) (A - Ground)
-----------------------------	--

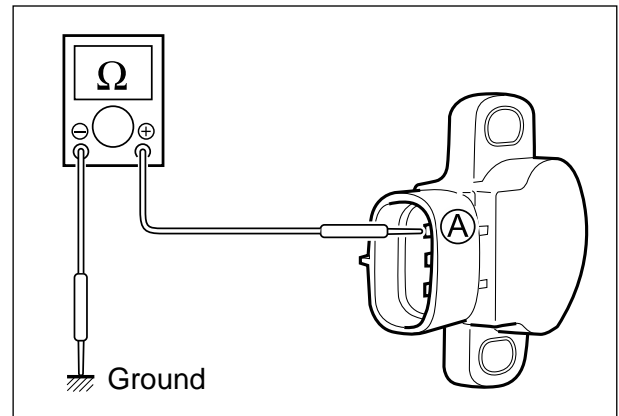

- 5) If OK, then measure the TP sensor resistance (between (A) and (B)).
- 6) Turn the throttle grip and measure the resistance.

TP sensor resistance	
Throttle valve is closed	Approx. 1.81 K Ω
Throttle valve is opened	Approx. 4.75 K Ω

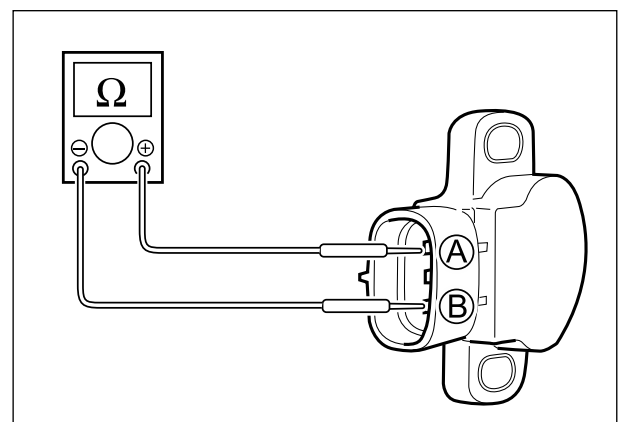

 **Tester knob indication : Resistance (Ω)**

Are the resistance and continuity OK?

YES	Go to Step 3.
NO	<ul style="list-style-type: none"> ● Reset the TP sensor position correctly. ● Replace the TP sensor with a new one.

4-19 FI SYSTEM DIAGNOSIS

◆ Step 3

- 1) Connect the TP sensor coupler.
- 2) Insert the needle pointed probes to the lead wire coupler.
- 3) Turn the ignition switch "ⓐ" (ON) position.
Measure the TP sensor output voltage at the coupler (between ⊕ LY and ⊖ BW) by turning the throttle grip.

TP sensor output voltage	
Throttle valve is closed	Approx. 1.12 V
Throttle valve is opened	Approx. 4.18 V

 **Tester knob indication : Voltage (---)**

Is the voltage OK?

YES	<ul style="list-style-type: none"> ● OB, LY or BW wire open or shorted to ground, or poor ⑰, ⑥, or ⑤ connection. ● If wire and connection are OK, intermittent trouble or faulty ECU. ● Recheck each terminal and wire harness for open circuit and poor connection.
NO	If check result is not satisfactory, replace TP sensor with a new one.

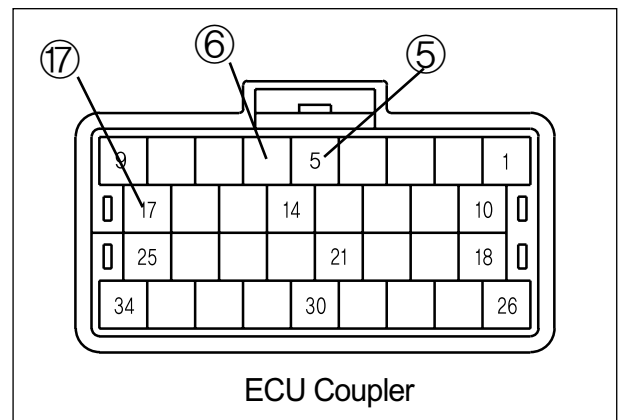
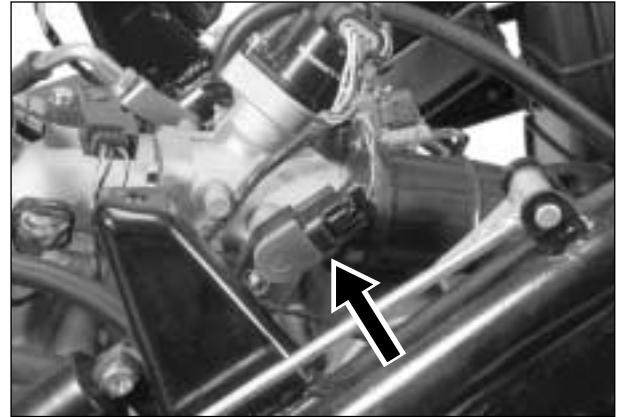

“C15” WT SENSOR CIRCUIT MALFUNCTION

DETECTED CONDITION	POSSIBLE CAUSE
Output voltage is out of the specified range. 0.1 V ≤ Sensor voltage < 4.6 V	<ul style="list-style-type: none"> ● WT sensor circuit open or short. ● WT sensor malfunction. ● ECU malfunction.

INSPECTION

◆ Step 1

- 1) Turn the ignition switch “” (OFF) position.
- 2) Check the WT sensor coupler for loose or poor contacts.

If OK, then measure the WT sensor voltage at the wire side coupler.

- 3) Disconnect the coupler and turn the ignition switch “” (ON) position.

- 4) Measure the voltage between G wire terminal and ground.

- 5) If OK, then measure the voltage between G wire terminal and BW wire terminal.

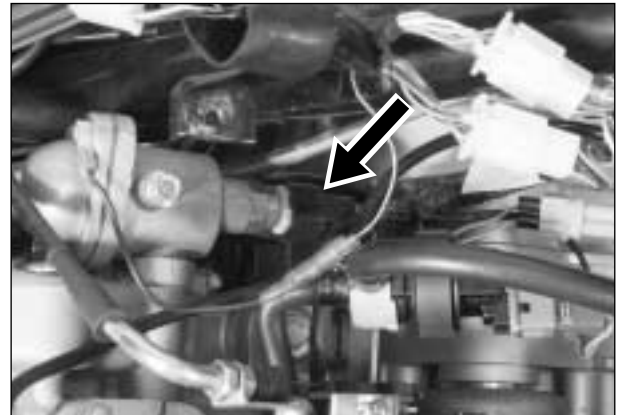

WT sensor voltage

4.5 ~ 5.5 V
 (⊕ G — ⊖ Ground)
 (⊕ G — ⊖ BW)

 Tester knob indication : Voltage (—)

Is the voltage OK?

YES	Go to Step 2.
NO	<ul style="list-style-type: none"> ● Loose or poor contacts on the ECU coupler. ● Open or short circuit in the G wire or BW wire.

4-21 FI SYSTEM DIAGNOSIS

◆ Step 2

- 1) Turn the ignition switch "⊗" (OFF) position.
- 2) Measure the WT sensor resistance. (Refer to page 6-8 for details.)

WT sensor resistance	
Engine Coolant Temp.	Resistance (To ECU)
0 °C (32 °F)	Approx. 5.790 kΩ
20 °C (68 °F)	Approx. 2.450 kΩ
40 °C (104 °F)	Approx. 1.148 kΩ
60 °C (140 °F)	Approx. 0.586 kΩ
80 °C (176 °F)	Approx. 0.322 kΩ

🔧 Tester knob indication : Resistance (kΩ)

Is the voltage OK?

YES	<ul style="list-style-type: none"> ● G or BW wire open or shorted to ground, or poor⑧ or⑤ connection. ● If wire and connection are OK, intermittent trouble or faulty ECU. ● Recheck each terminal and wire harness for open circuit and poor connection.
NO	Replace the WT sensor with a new one.

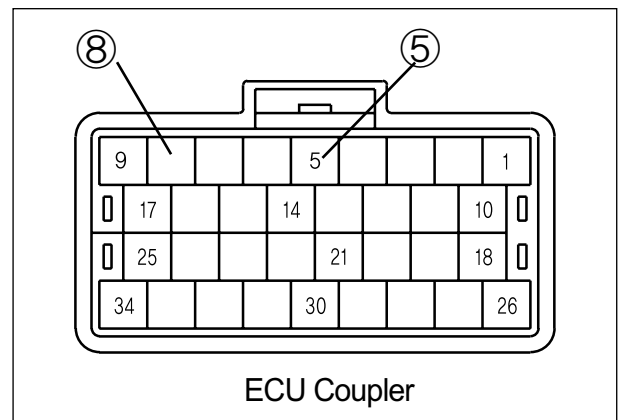

“C17” IAP SENSOR CIRCUIT MALFUNCTION

DETECTED CONDITION	POSSIBLE CAUSE
<p>IAP sensor voltage is out of the specified range. $0.1\text{ V} \leq \text{Sensor voltage} \leq 4.8\text{ V}$ NOTE : <i>Note that atmospheric pressure varies depending on weather conditions as well as altitude. Take that into consideration when inspecting voltage.</i></p>	<ul style="list-style-type: none"> ● Clogged vacuum passage between throttle body and IAP sensor. ● Air being drawn from vacuum passage between throttle body and IAP sensor. ● IAP sensor circuit open or shorted to ground. ● IAP sensor malfunction. ● ECU malfunction.

▣ INSPECTION

◆ Step 1

- 1) Lift and support the side cover with the side cover stay. (Refer to page 2-2)
- 2) Turn the ignition switch “” (OFF) position.
- 3) Check the IAP sensor coupler for loose or poor contacts. If OK, then measure the IAP sensor input voltage.

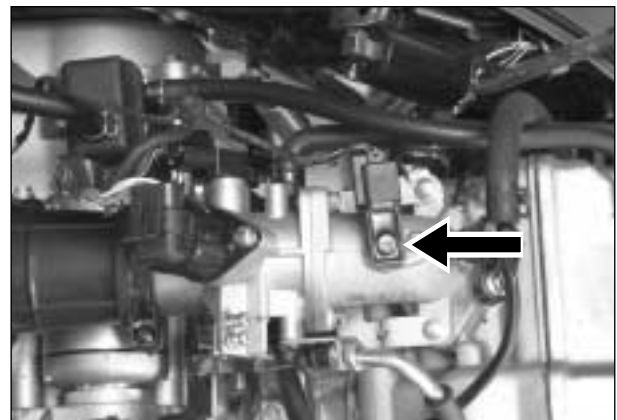

- 4) Disconnect the IAP sensor coupler.
- 5) Turn the ignition switch “” (ON) position.
- 6) Measure the voltage at the OB wire and ground. If OK, then measure the voltage at the OB wire and BW wire.



IAP sensor input voltage	$4.5 \sim 5.5\text{ V}$ (⊕ OB — ⊖ Ground) (⊕ OB — ⊖ BW)
---------------------------------	---

 **Tester knob indication : Voltage (---)**

Is the voltage OK?

YES	Go to Step 2.
NO	<ul style="list-style-type: none"> ● Loose or poor contacts on the ECU coupler. ● Open or short circuit in the OB wire or BW wire.

4-23 FI SYSTEM DIAGNOSIS

◆ Step 2

- 1) Connect the IAP sensor coupler.
- 2) Insert the needle pointed probes to the lead wire coupler.
- 3) Start the engine at idle speed.
- 4) Measure the IAP sensor output voltage at the wire side coupler (between BL and BW wires).

IAP sensor output voltage

Approx. 4.0 ~ 4.2 V
when ignition switch "ⓘ" (ON)
(⊕ BL — ⊖ BW)

 Tester knob indication : Voltage (—)

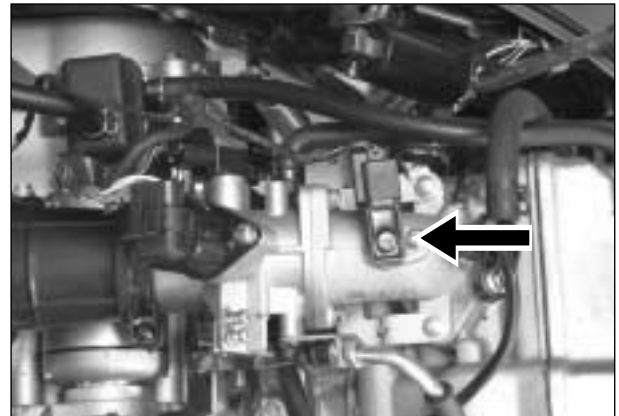

Is the voltage OK?

YES	<ul style="list-style-type: none"> ● OB, BL or BW wire open or shorted to ground, or poor ⑰, ⑳ or ⑤ connection. ● If wire and connection are OK, intermittent trouble or faulty ECU. ● Recheck each terminal and wire harness for open circuit and poor connection.
NO	If check result is not satisfactory, replace IAP sensor with a new one.

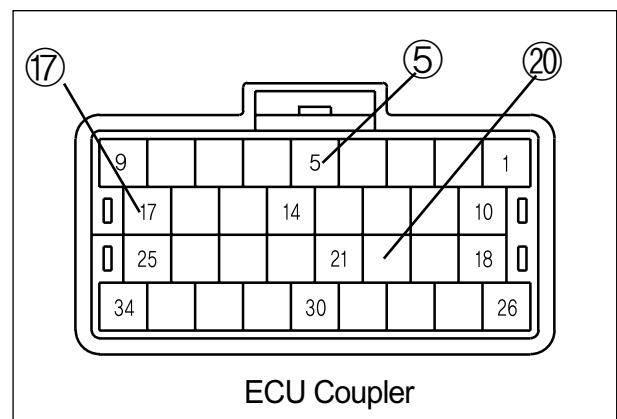

Output voltage (Input voltage 5 V, ambient temp. 25 °C, 77 °F)

ALTITUDE (Reference)		ATMOSPHERIC PRESSURE		OUTPUT VOLTAGE
(ft)	(m)	(mmHg)	kPa	(V)
0	0	760	100	Approx. 4.0 ~ 4.3
2 000	610	707	94	
2 001	611	707	94	Approx. 3.6 ~ 4.0
5 000	1 524	634	85	
5 001	1 525	634	85	Approx. 3.3 ~ 3.6
8 000	2 438	567	76	
8 001	2 439	567	76	Approx. 3.0 ~ 3.3
10 000	3 048	526	70	

“C21” IAT SENSOR CIRCUIT MALFUNCTION

DETECTED CONDITION	POSSIBLE CAUSE
Output voltage is out of the specified range. 0.1 V ≤ Sensor voltage < 4.6 V	<ul style="list-style-type: none"> ● IAT sensor circuit open or short. ● IAT sensor malfunction. ● ECU malfunction.

▣ INSPECTION

◆ Step 1

- 1) Lift and support the side cover with the side cover stay. (Refer to page 2-2)
- 2) Turn the ignition switch “⊗” (OFF) position.
- 3) Check the IAT sensor coupler for loose or poor contacts.
If OK, then measure the IAT sensor voltage at the wire side coupler.
- 4) Disconnect the coupler and turn the ignition switch “⊙” (ON) position.

- 5) Measure the voltage between Lg wire terminal and ground.
- 6) If OK, then measure the voltage between Lg wire terminal and BW wire terminal.

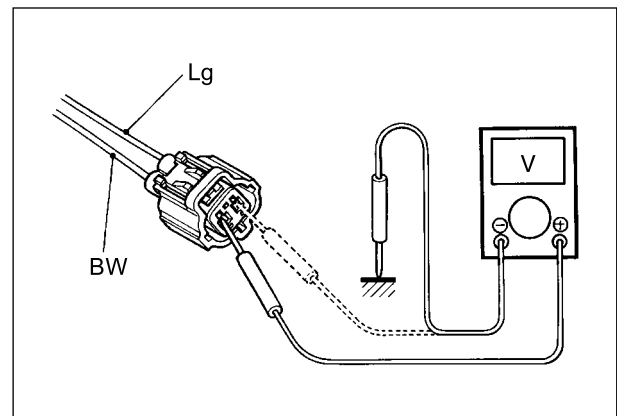
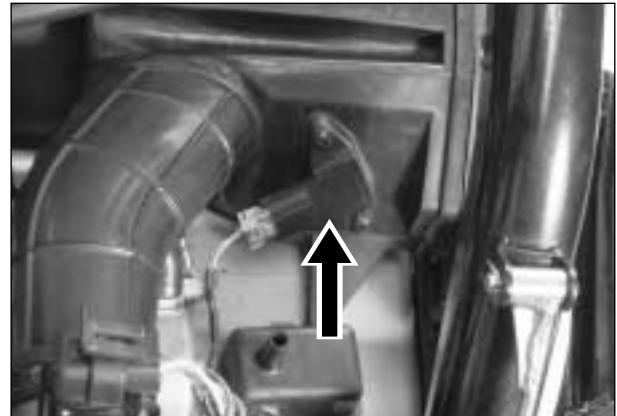

IAT sensor voltage	4.5 ~ 5.5 V (⊕ Lg — ⊖ Ground) (⊕ Lg — ⊖ BW)
---------------------------	---

Tester knob indication : Voltage (---)

Is the voltage OK?

YES	Go to Step 2.
NO	<ul style="list-style-type: none"> ● Loose or poor contacts on the ECU coupler. ● Open or short circuit in the Lg wire or BW wire.



4-25 FI SYSTEM DIAGNOSIS

◆ Step 2

- 1) Turn the ignition switch “” (OFF) position.
- 2) Measure the IAT sensor resistance.

IAT sensor resistance	
Intake Air Temp.	Resistance
-10 °C (14 °F)	Approx. 53.30 KΩ
0 °C (32 °F)	Approx. 31.52 KΩ
20 °C (68 °F)	Approx. 12.33 KΩ
40 °C (104 °F)	Approx. 5.19 KΩ
60 °C (140 °F)	Approx. 2.42 KΩ

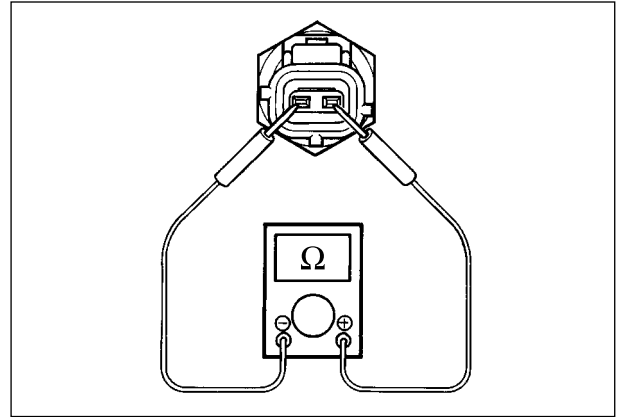

Tester knob indication : Resistance (KΩ)

Is the voltage OK?

YES	<ul style="list-style-type: none"> ● Lg or BW wire open or shorted to ground, or poor ② or ⑤ connection. ● If wire and connection are OK, intermittent trouble or faulty ECU. ● Recheck each terminal and wire harness for open circuit and poor connection.
NO	Replace the IAT sensor with a new one.

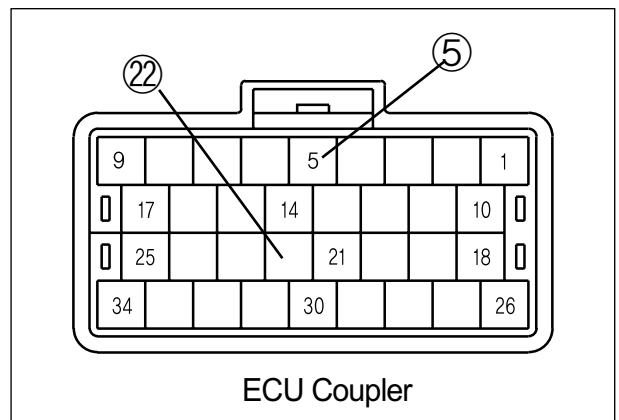

NOTE

IAT sensor resistance measurement method is the same way as that of the WT sensor. Refer to page 6-8 for details.

“C22” OXYGEN SENSOR CIRCUIT MALFUNCTION

DETECTED CONDITION	POSSIBLE CAUSE
Oxygen sensor signal is not input in ECU since then more than 120 sec after the engine run.	<ul style="list-style-type: none"> ● Oxygen sensor, Oxygen sensor heater circuit open or short. ● Oxygen sensor, Oxygen sensor heater malfunction. ● ECU malfunction.

▣ INSPECTION

- 1) Remove the right side front lower cover.
- 2) Turn the ignition switch “” (OFF) position.
- 3) Check the Oxygen sensor coupler for loose or poor contacts.

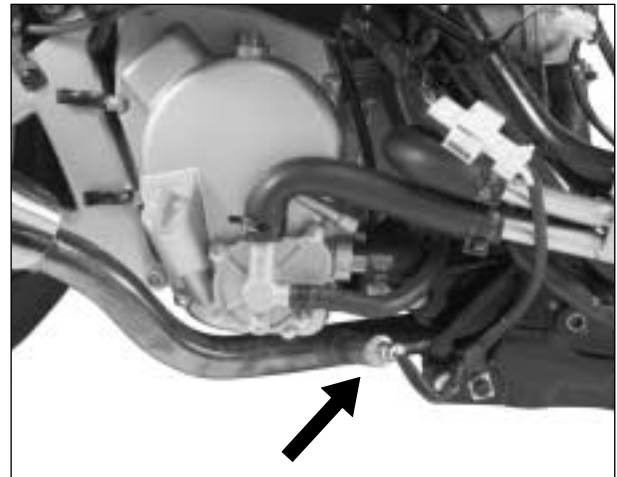

Is OK?

YES	<ul style="list-style-type: none"> ● BR or BW wire open or shorted to ground, or poor ③① or ⑤ connection. ● If wire and connection are OK, intermittent trouble or faulty ECU. ● Recheck each terminal and wire harness for open circuit and poor connection.
NO	Replace the Oxygen sensor.

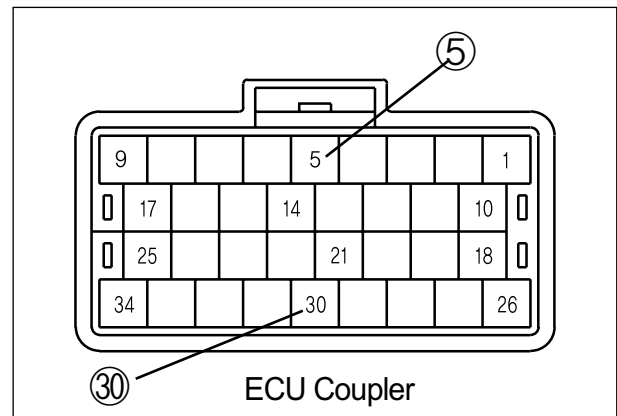

“C23” TO SENSOR CIRCUIT MALFUNCTION

DETECTED CONDITION	POSSIBLE CAUSE
Output voltage is out of the specified range. 4.5 V ≤ Sensor voltage ≤ 5.5 V	<ul style="list-style-type: none"> ● TO sensor circuit short or leaned more than 60°. ● TO sensor malfunction. ● ECU malfunction.

▣ INSPECTION

- 1) Lift and support the side cover with the side cover stay. (Refer to page 2-2)
- 2) Turn the ignition switch “⊗” (OFF) position.
- 3) Check the TO sensor coupler for loose or poor contacts.
- 4) Remove the TO sensor.



Is OK?

YES	<ul style="list-style-type: none"> ● YL or BW wire open or shorted to ground, or poor ⑮ or ⑤ connection. ● If wire and connection are OK, intermittent trouble or faulty ECU. ● Recheck each terminal and wire harness for open circuit and poor connection.
NO	Replace the TO sensor with a new one.

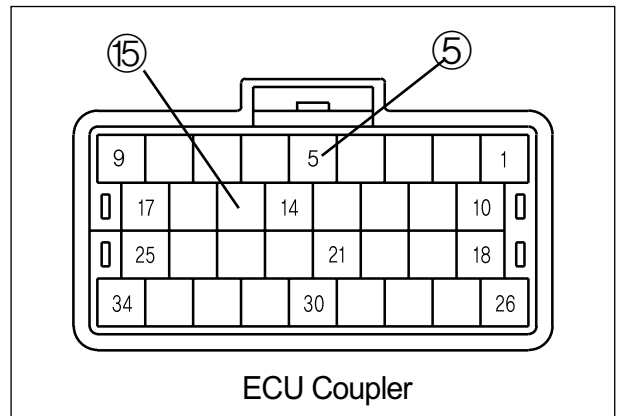

“C24” IGNITION COIL MALFUNCTION

☞ Refer to the IGNITION COIL for details. (Refer to page 7-3)

“C27” ISC SOLENOID RANGE ABNORMAL

DETECTED CONDITION	POSSIBLE CAUSE
ISC solenoid's step is out of the specified range. ○ step \leq solenoid step \leq 100 step	<ul style="list-style-type: none"> ● ISC solenoid ● ISC solenoid's step is out of the specific range. ● ECU malfunction.

▣ INSPECTION

- 1) Lift and support the side cover with the side cover stay. (Refer to page 2-2)
- 2) Turn the ignition switch “⊗” (OFF) position.
- 3) Check the ISC solenoid coupler for loose or poor contacts.
- 4) Turn the ignition switch “○” (ON) position to check the ISC solenoid operation.

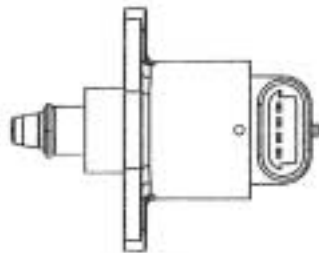

[When Ignition switch “⊗” (OFF)]

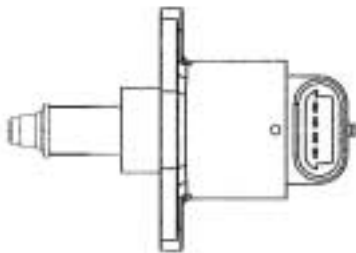

[When Ignition switch “○” (ON)]

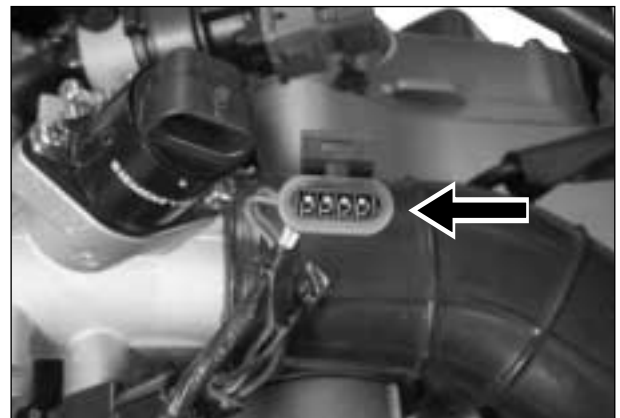
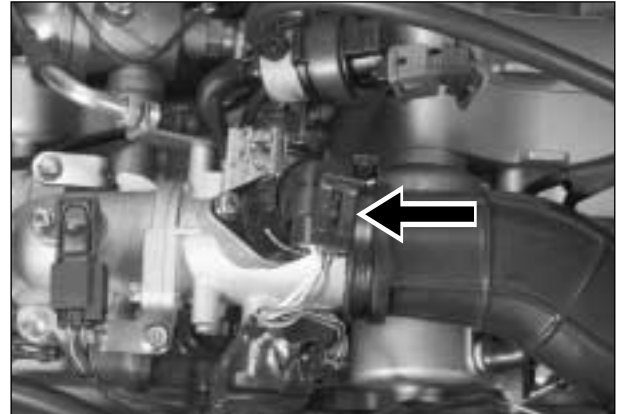

Is OK?

YES	<ul style="list-style-type: none"> ● Gr, GR, Y or W wire loose or poor contacts on the ISC solenoid coupler, or poor ③④, ③②, ③③ or ②⑤ connection. ● If wire and connection are OK, intermittent trouble or faulty ECU. Recheck each terminal and wire harness for open circuit and poor connection.
NO	Replace the ISC solenoid with a new one.

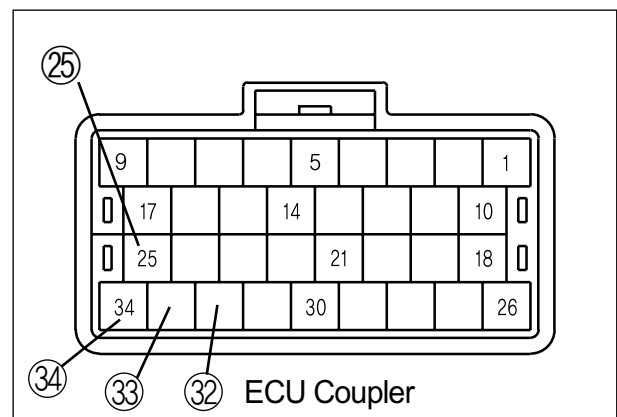

“C32” FUEL INJECTOR CIRCUIT MALFUNCTION

DETECTED CONDITION	POSSIBLE CAUSE
Fuel injector not comes in voltage from battery.	<ul style="list-style-type: none"> ● Injector circuit open or short. ● Injector malfunction. ● ECU malfunction.

▣ INSPECTION

◆ Step 1

- 1) Lift and support the side cover with the side cover stay. (Refer to page 2-2)
- 2) Turn the ignition switch “” (OFF) position.
- 3) Check the injector couplers for loose or poor contacts.
If OK, then measure the injector resistance.



- 4) Disconnect the injector couplers and measure the resistance between terminals.

Injector resistance	11.5 ~ 13.5 Ω at 20 °C (68°F) (1 - 2)
----------------------------	--

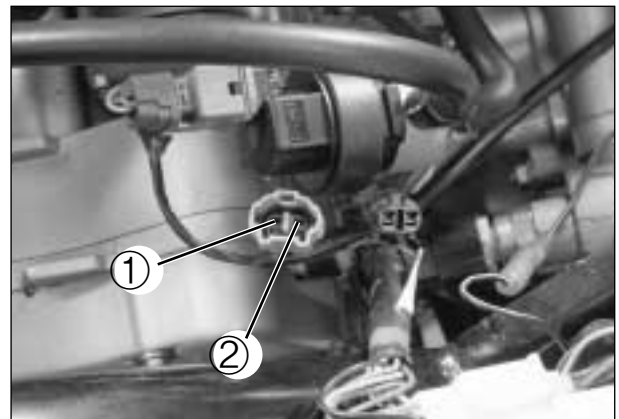

- 5) If OK, then check the continuity between injector terminals and ground.

Injector continuity	∞ Ω (Infinity) (1 - Ground)
----------------------------	--------------------------------

Tester knob indication : Resistance (Ω)

Is the resistance OK?

YES	Go to Step 2
NO	Replace the Injector with a new one. (Refer to page 5-12)

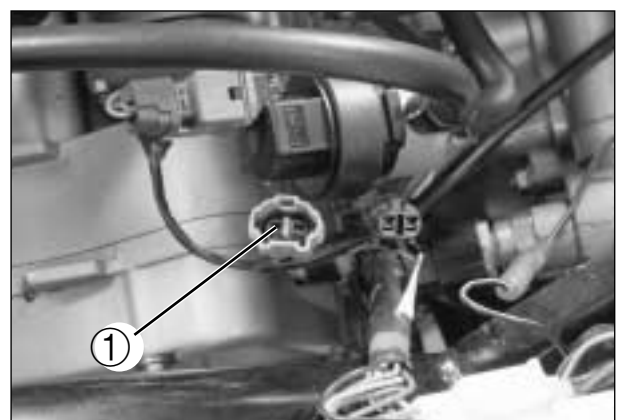

◆ Step 2

- 1) Turn the ignition switch “Ⓞ” (ON) position.
- 2) Measure the injector voltage between YG wire and ground.

Injector voltage	Battery voltage (⊕ YG – ⊖ Ground)
-------------------------	--------------------------------------

 **Tester knob indication : Voltage (---)**

NOTE

Injector voltage can be detected only 3 seconds after ignition switch is turned “Ⓞ” (ON) position.



Is the voltage OK?

YES	<ul style="list-style-type: none"> ● YG wire open or shorted to ground, or poor[Ⓢ] connection. ● If wire and connection are OK, intermittent trouble or faulty ECU. ● Recheck each terminal and wire harness for open circuit and poor connection.
NO	<ul style="list-style-type: none"> ● Inspect the fuel pump or fuel pump relay. (Refer to page 5-4)

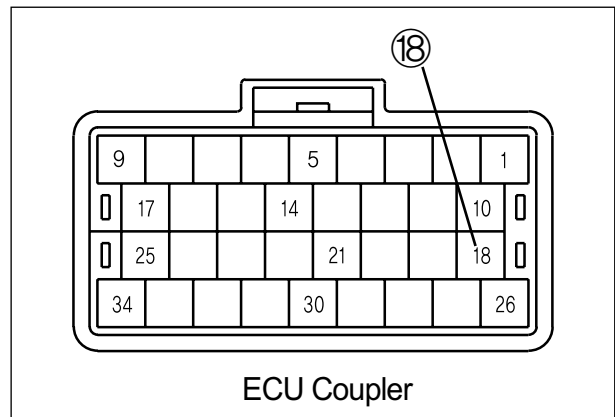

“C37” SAV SOLENOID MALFUNCTION

DETECTED CONDITION	POSSIBLE CAUSE
SAV solenoid voltage is not input in ECU.	<ul style="list-style-type: none"> ● SAV solenoid circuit open or short. ● SAV solenoid malfunction. ● ECU malfunction.

▣ INSPECTION

- 1) Lift and support the side cover with the side cover stay. (Refer to page 2-2)
- 2) Turn the ignition switch “⊗” (OFF) position.
- 3) Check the SAV solenoid coupler for loose or poor contacts.
- 4) Connect the SAV solenoid coupler.
- 5) Turn the ignition switch “⊙” (ON) position.
- 6) Measure the voltage at the wire side coupler between GL wire and ground.

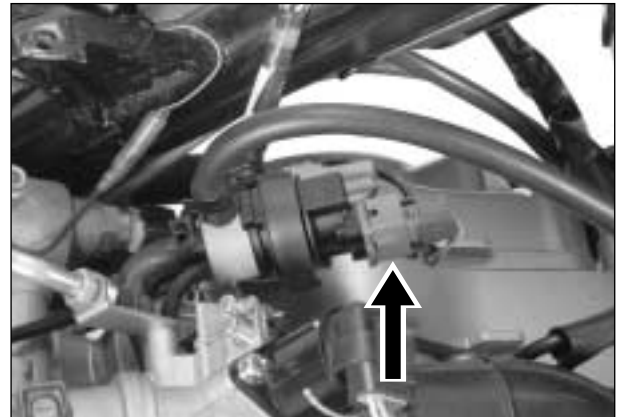

SAV solenoid voltage	Battery voltage (⊕ GL – ⊖ Ground)
-----------------------------	--------------------------------------

- Pocket tester : 09900-25002**
- Tester knob indication : Voltage (---)**



Is the voltage OK?

YES	<ul style="list-style-type: none"> ● GL wire open or shorted to ground, or connection. ● If wire and connection are OK, intermittent trouble or faulty ECU. ● Recheck each terminal and wire harness for open circuit and poor connection.
NO	Replace the SAV solenoid with a new one.

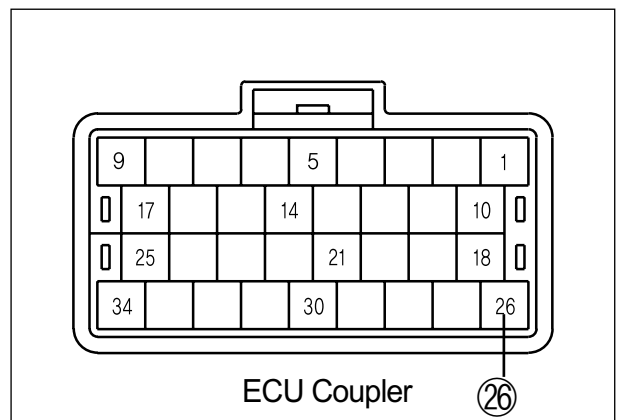

“C41” FUEL PUMP RELAY CIRCUIT MALFUNCTION

DETECTED CONDITION	POSSIBLE CAUSE
No voltage is applied to the both injectors for 3 sec. after the contact of fuel pump relay is turned “ON” position. Or voltage is applied to the both injectors, when the contact of fuel pump is “OFF” position.	<ul style="list-style-type: none"> ● Fuel pump relay circuit open or short. ● Fuel pump relay malfunction. ● ECU malfunction.

▣ INSPECTION

◆ Step 1

- 1) Remove the left lower leg rear shield.
(Refer to page 8-7)
- 2) Turn the ignition switch “” (OFF) position.
- 3) Check the fuel pump relay coupler for loose or poor contacts.
If OK, then check the insulation and continuity.
Refer to page 5-4 for details.

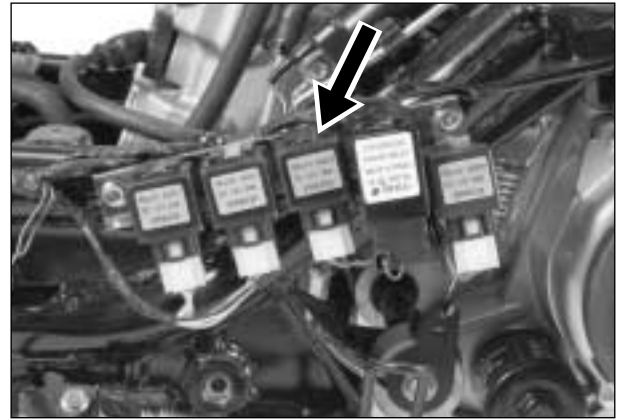

Is the Fuel pump relay OK?

YES	<ul style="list-style-type: none"> ● GW wire open or shorted to ground, or poor② connection. ● If wire and connection are OK, intermittent trouble or faulty ECU. ● Recheck each terminal and wire harness for open circuit and poor connection. ● Inspect the fuel injectors. (Refer to page 4-29)
NO	Replace the fuel pump relay with a new one.

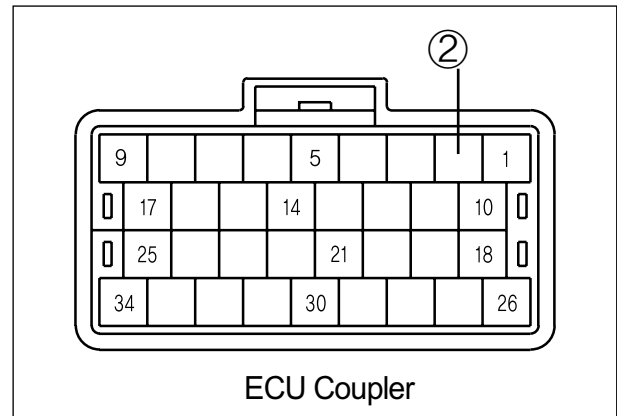

“C43” OXYGEN SENSOR HEATER CIRCUIT MALFUNCTION

DETECTED CONDITION	POSSIBLE CAUSE
Oxygen sensor heater signal is not input in ECU.	<ul style="list-style-type: none"> ● Oxygen sensor, Oxygen sensor heater circuit open or short. ● Oxygen sensor, Oxygen sensor heater malfunction. ● ECU malfunction.

▣ INSPECTION

- 1) Remove the right side front lower cover.
- 2) Turn the ignition switch “” (OFF) position.
- 3) Check the Oxygen sensor heater coupler for loose or poor contacts.
If OK, then measure the Oxygen sensor heater voltage.
- 4) Disconnect the coupler and then the ignition switch “” (ON) position.
- 5) Measure the voltage between OB wire terminal and B (or ground) wire terminal.

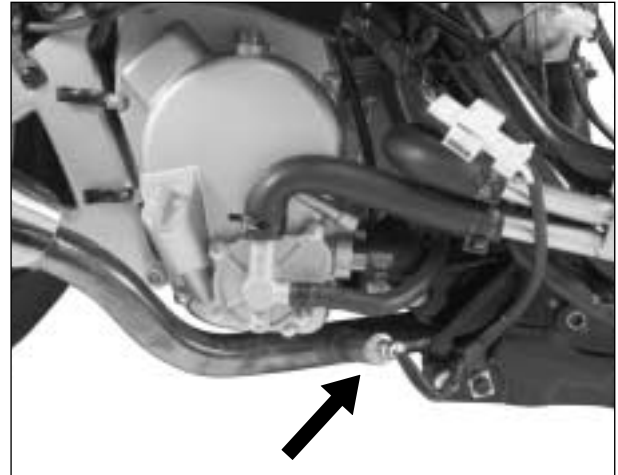

Oxygen sensor heater voltage	Battery voltage (⊕ OB – ⊖ B) (⊕ OB – ⊖ Ground)
-------------------------------------	--

Tester knob indication : Voltage (---)

Is the voltage OK?

YES	<ul style="list-style-type: none"> ● OB or B wire open or shorted to ground, or poor ¹⁷ or ²⁷ connection. ● If wire and connection are OK, intermittent trouble or faulty ECU. ● Recheck each terminal and wire harness for open circuit and poor connection.
NO	Replace the Oxygen sensor.

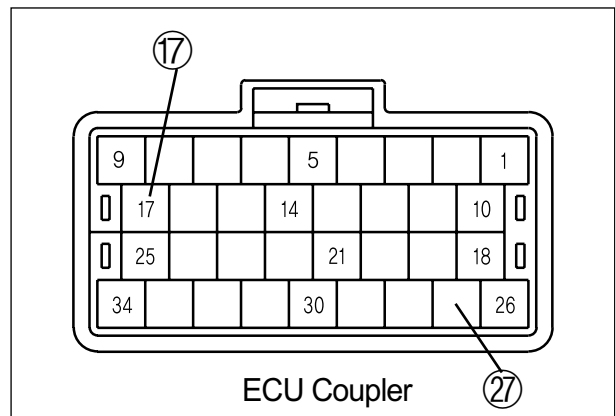

SENSORS

⊙ PICK-UP COIL INSPECTION

The pick-up coil ① is installed in the magneto cover.
(Refer to page 7-6)

⊙ PICK-UP COIL REMOVAL AND INSTALLATION

- Remove the magneto cover. (Refer to page 3-7)
- Install the magneto cover in the reverse order of removal.

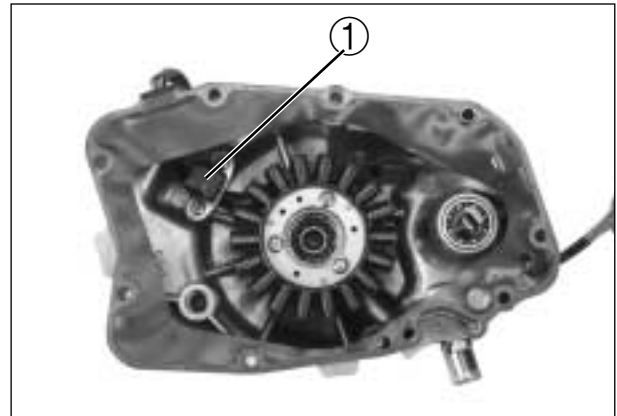

⊙ IAP SENSOR INSPECTION

The intake air pressure (IAP) sensor ② is installed at the upside of the intake pipe. (Refer to page 4-22)

⊙ IAP SENSOR REMOVAL AND INSTALLATION

- Lift and support the side cover with the side cover stay. (Refer to page 2-2)
- Remove the IAP sensor from the intake pipe.
- Install the IAP sensor in the reverse order of removal.



⊙ TP SENSOR INSPECTION

The throttle position (TP) sensor ③ is installed at the left side of the throttle body. (Refer to page 4-17)

⊙ TP SENSOR REMOVAL AND INSTALLATION

 CAUTION
Never remove the TP sensor.

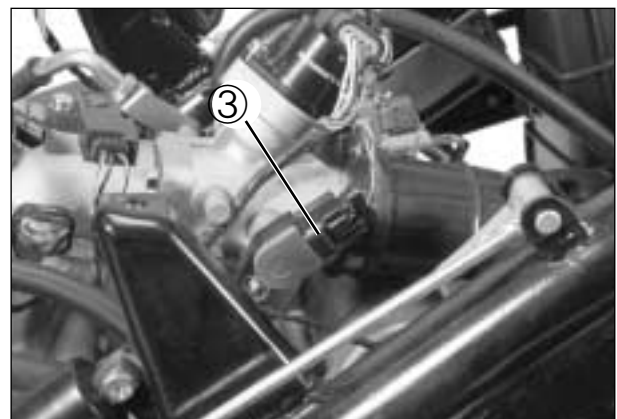

⊙ WT SENSOR INSPECTION

The water temperature (WT) sensor ④ is installed at the rear side of the thermostat case. (Refer to page 4-20)

⊙ WT SENSOR REMOVAL AND INSTALLATION

- Remove the WT sensor. (Refer to page 6-8)
- Install the WT sensor in the reverse order of removal.

 WT sensor : 18 N · m (1.8 kgf · m)

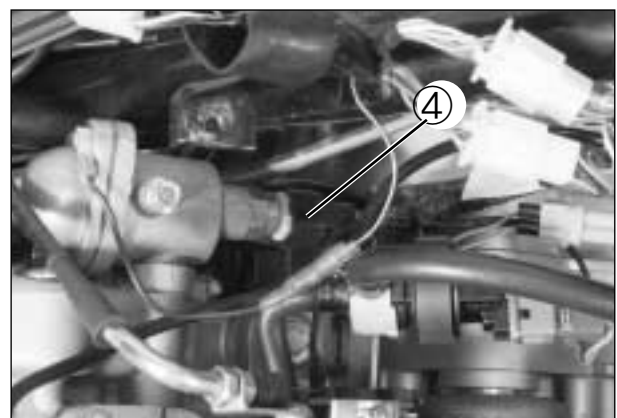

⊙ IAT SENSOR INSPECTION

The intake air temperature (IAT) sensor ① is installed at the left side of the air cleaner case. (Refer to page 4-24)

⊙ IAT SENSOR REMOVAL AND INSTALLATION

- Lift and support the side cover with the side cover stay. (Refer to page 2-2)
- Remove the IAT sensor from the air cleaner case.
- Install the IAT sensor in the reverse order of removal.

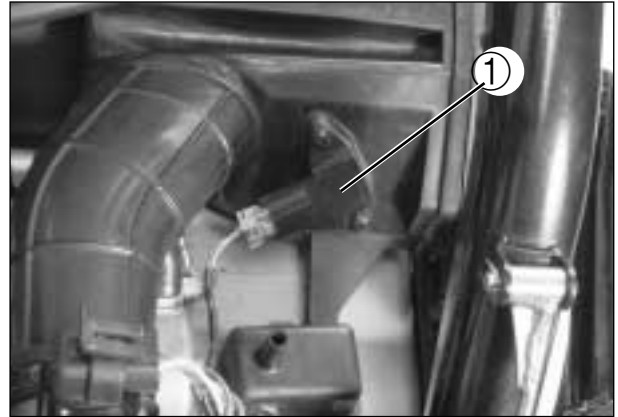

⊙ TO SENSOR INSPECTION, REMOVAL AND INSTALLATION

The tip over (TO) sensor ② is located in the side front cover. (Refer to page 4-27)

- Lift and support the side cover with the side cover stay. (Refer to page 2-2)
- Remove the TO sensor from the side front cover.
- Install the TO sensor in the reverse order of removal.



FUEL SYSTEM AND THROTTLE BODY

CONTENTS

FUEL SYSTEM	5- 1
REMOVAL AND DISASSEMBLY	5- 2
REASSEMBLY AND INSTALLATION	5- 3
FUEL PRESSURE INSPECTION	5- 4
FUEL PUMP RELAY INSPECTION	5- 4
FUEL MESH FILTER INSPECTION AND CLEANING	5- 5
FUEL LEVEL GAUGE INSPECTION	5- 5
THROTTLE BODY	5- 6
REMOVAL	5- 7
DISASSEMBLY	5- 8
CLEANING	5-10
INSPECTION	5-10
REASSEMBLY	5-11
INSTALLATION	5-12
THROTTLE CABLE ADJUSTMENT	5-12
FUEL INJECTOR REMOVAL	5-12
FUEL INJECTOR INSPECTION	5-12
FUEL INJECTOR INSTALLATION	5-12

FUEL SYSTEM

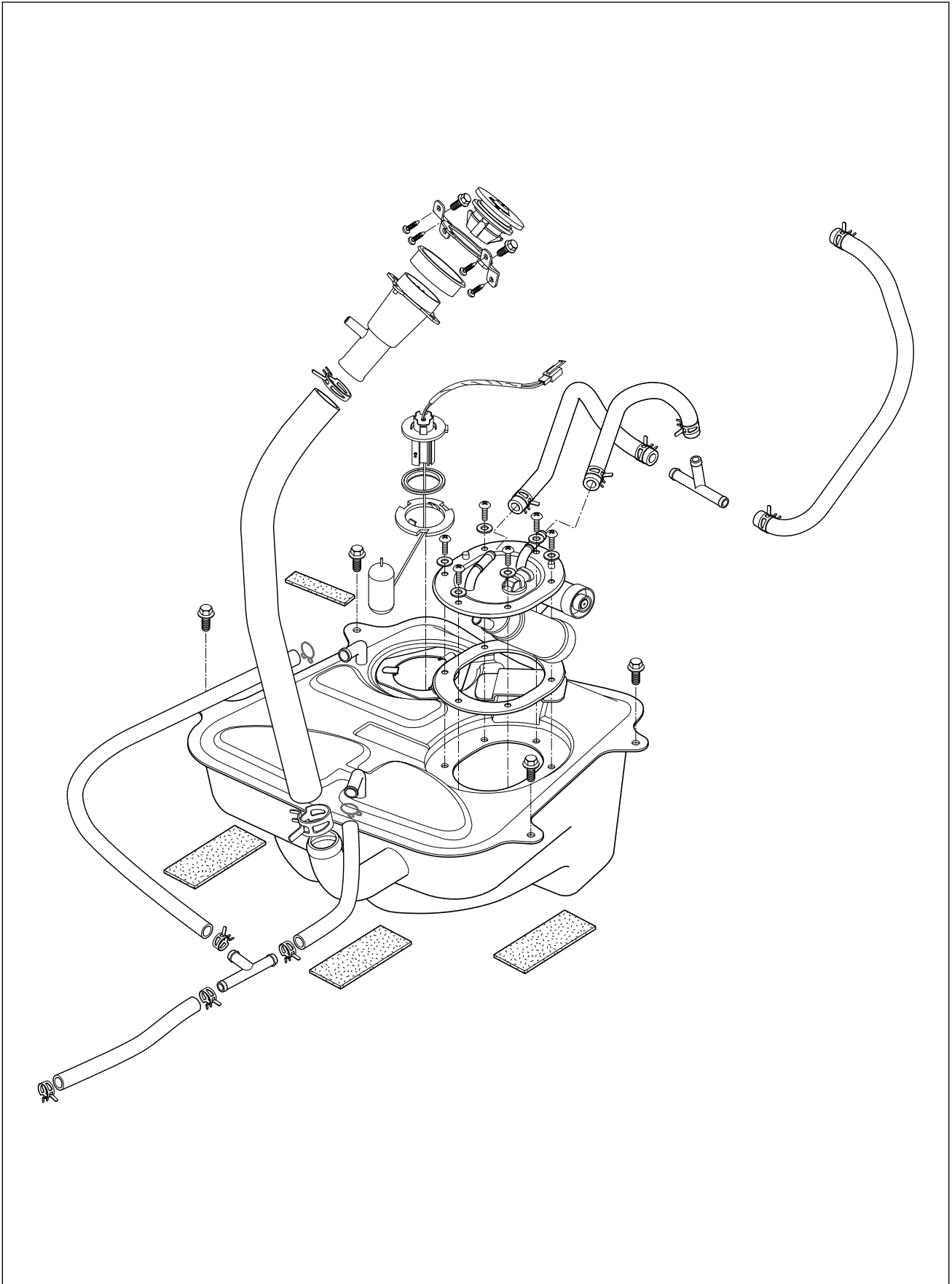

REMOVAL AND DISASSEMBLY

- Remove the rear leg shield.(Refer to page 8-7)
- Remove the lower leg rear shield. (Refer to page 8-7)
- Remove the 『Seat, side cover & rear fender assembly』. (Refer to page 8-7)

- Disconnect the fuel level gauge coupler① .

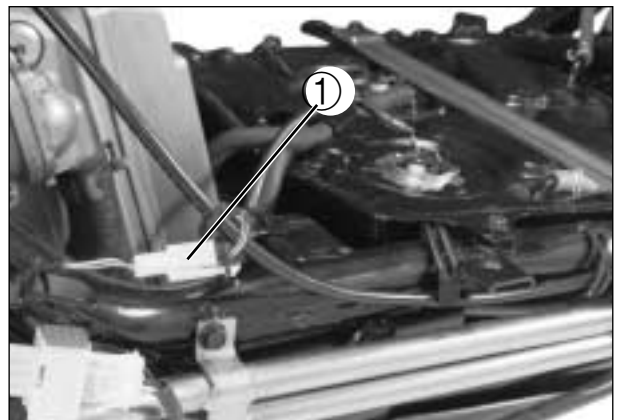

- Remove the fuel tank guide② .
- Remove the fuel tank mounting bolts.

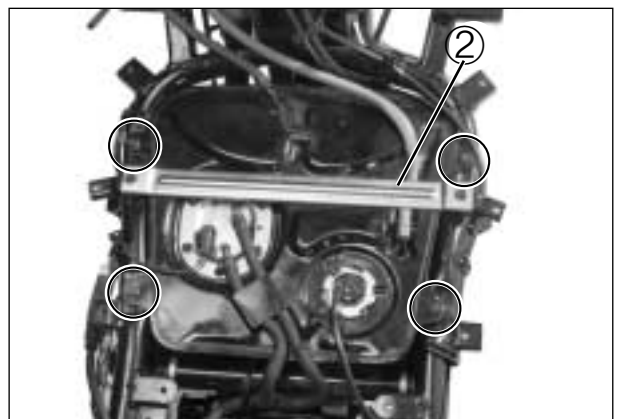

- Remove the fuel pump coupler③ .
- Remove the fuel injector hose ④ , return hose ⑤ and breather hose⑥ .

⚠ CAUTION

After disconnecting the fuel injector hose ④ , insert a blind plug into the end to stop fuel leakage.

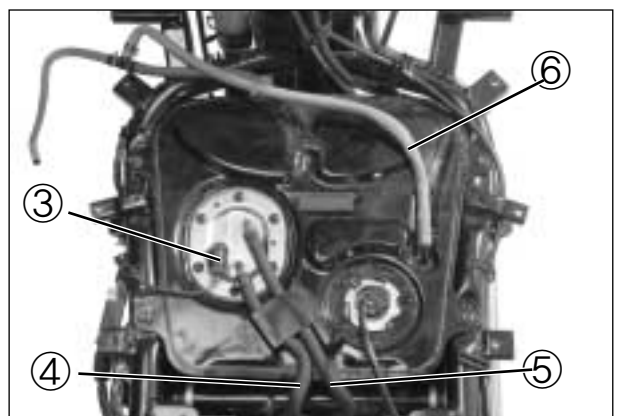

5-3 FUEL SYSTEM AND THROTTLE BODY

- Remove the fuel tank forward.

 **CAUTION**

As gasoline leakage may occur in this operation, keep away from fire and sparks.

- Remove the fuel pump assembly ① by removing its mounting bolts diagonally.

 **WARNING**

- ❖ Gasoline is highly flammable and explosive.
- ❖ Keep heat, spark and flame away.

- Remove the fuel gauge ② .



REASSEMBLY AND INSTALLATION

Reassembly and installation the fuel tank in the reverse order of removal and disassembly.

- When installing the fuel pump assembly, first tighten all the fuel pump assembly mounting bolts lightly in diagonal stages, and then tighten them in the above tightening order.

NOTE

Apply a small quantity of the **THREAD LOCK "1324"** to the thread portion of the fuel pump mounting bolt.

 **THREAD LOCK "1324"**

- Tighten the fuel tank mounting bolts to the specified torque.

 **Fuel tank mounting bolt**
: 8 ~ 12 N · m (0.8 ~ 1.2 kgf · m)

- Tighten the fuel tank guide bolts.

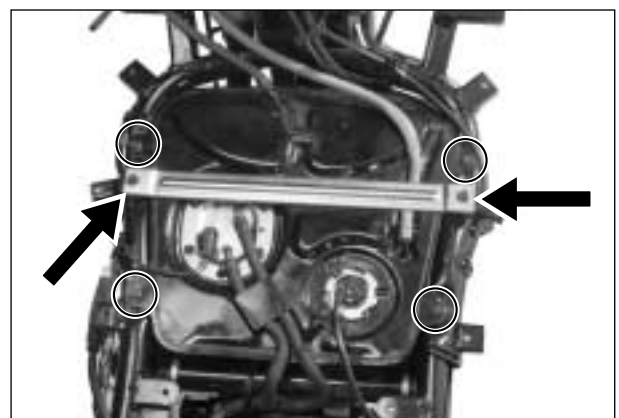

FUEL PRESSURE INSPECTION

- Lift and support the side cover with the side cover stay. (Refer to page 2-2)
- Place a rag under the fuel injector hose.
- Disconnect the fuel injector hose from the fuel delivery pipe.
- Install the special tool between the fuel tank and fuel delivery pipe.

 **Fuel pump pressure gauge**
: 09915-54510

Turn the ignition switch “” (ON) position and check the fuel pressure.

Fuel pressure

Approx. 3.4 ~ 3.7 kgf/cm²
(333 ~ 363 kPa, 48.4 ~ 52.6 psi)

If the fuel pressure is lower than the specification, inspect the following items :

- * Fuel hose leakage
- * Clogged fuel filter
- * Pressure regulator
- * Fuel pump

If the fuel pressure is higher than the specification, inspect the following items :

- * Fuel pump check valve
- * Pressure regulator

WARNING

- Before removing the special tool, turn the ignition switch to “” (OFF) position and release the fuel pressure slowly.
- Gasoline is highly flammable and explosive. Keep heat, sparks and flame away.

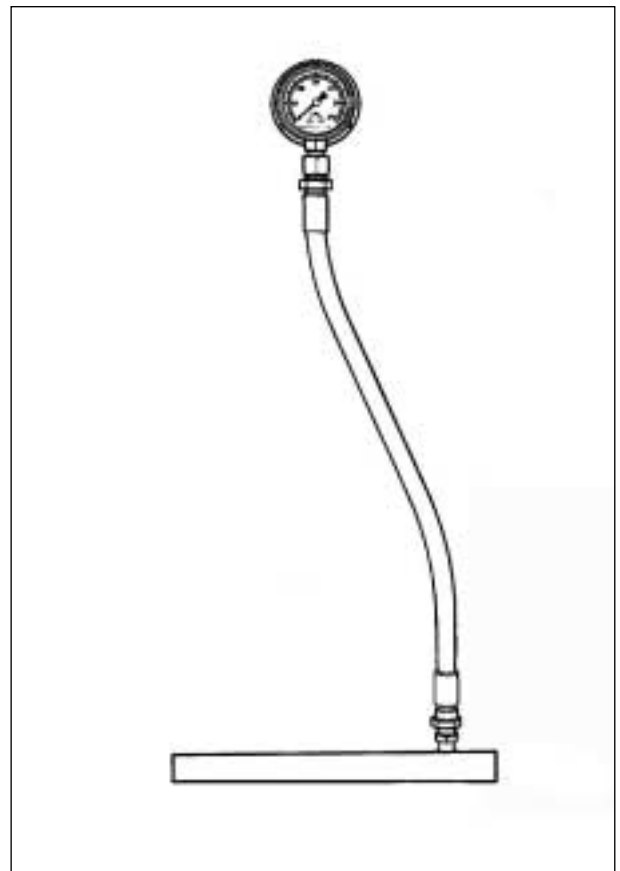

FUEL PUMP RELAY INSPECTION

Fuel pump relay is located upside the center stand.

- Remove the left lower leg rear shield. (Refer to page 8-7)
- Remove the fuel pump relay .

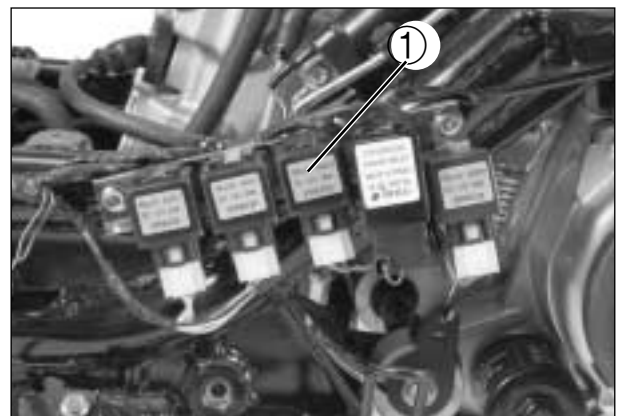

5-5 FUEL SYSTEM AND THROTTLE BODY

First, check the insulation between ① and ② terminals with pocket tester. Then apply 12 volts to ③ and ④ terminals, ⊕ to ③ and ⊖ to ④, and check the continuity between ① and ②.

If there is no continuity, replace it with a new one.

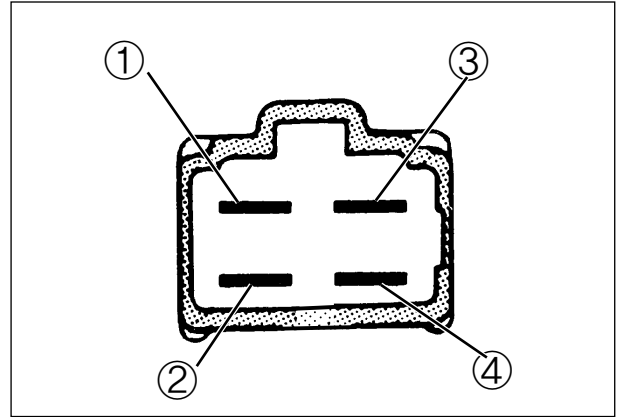

FUEL MESH FILTER INSPECTION AND CLEANING

- If the fuel mesh filter is clogged with sediment or rust, fuel will not flow smoothly and loss in engine power may result.
- Blow the fuel mesh filter with compressed air.

NOTE

If the fuel mesh filter is clogged with many sediment or rust, replace the fuel filter cartridge with a new one.



FUEL LEVEL GAUGE INSPECTION

- Measure resistance between the terminals when float is at the position instead below.

Fuel float position	Resistance between terminals
F	Approx. 4 ~ 10 Ω
1/2	Approx. 35 ~ 45 Ω
E	Approx. 95 ~ 105 Ω

- If the resistance measured is out of the specification, replace the gauge with a new one.
- Fuel level meter inspection. (Refer to page 7-14)

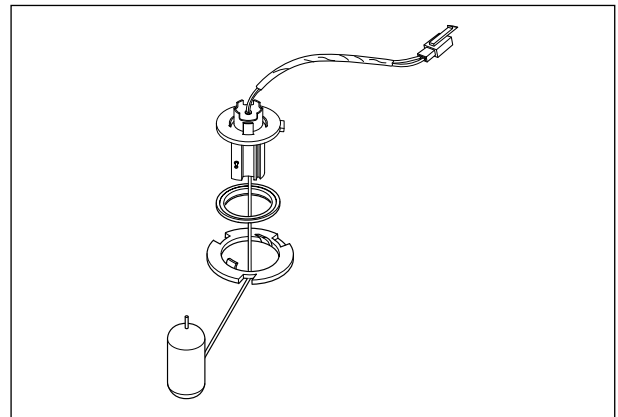

REMOVAL

- Lift and support the side cover with the side cover stay. (Refer to page 2-2)
- Remove the all coupler to related the throttle body.
- Loosen the clamp screw①.

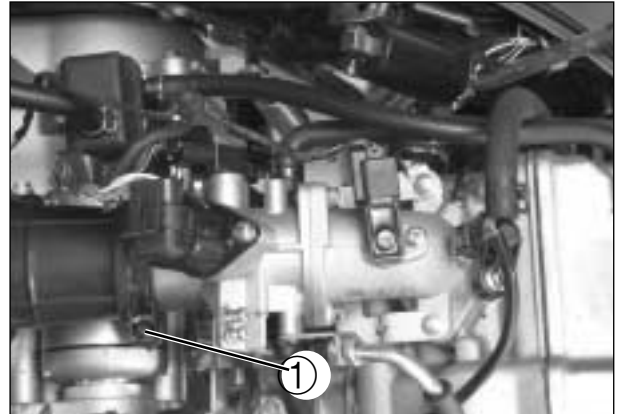

- Disconnect the throttle cable②.

⚠ CAUTION

After disconnecting the throttle cable, do not snap the throttle valve from full open to full close. If may cause damage to the throttle valve and throttle body.



- Disconnect the fuel injector hose③ and breather hose④.

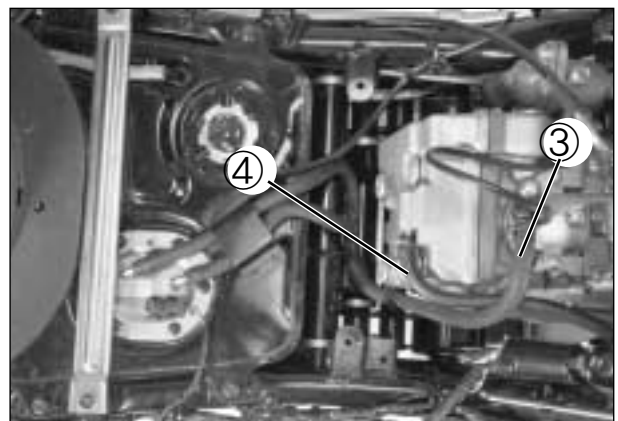

- Loosen the intake pipe bolt⑤.
- Remove the throttle body assembly⑥.
- Remove the insulator⑦ and O-ring.

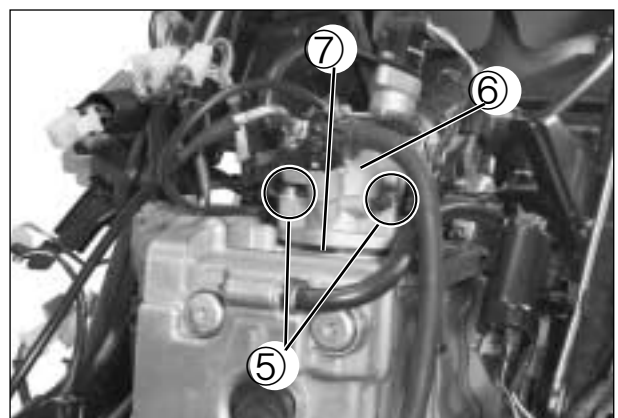

DISASSEMBLY

⚠ CAUTION

The throttle body is assembled precisely in factory. Do not disassemble it other than shown in this manual.



- Remove the ISC solenoid ①.

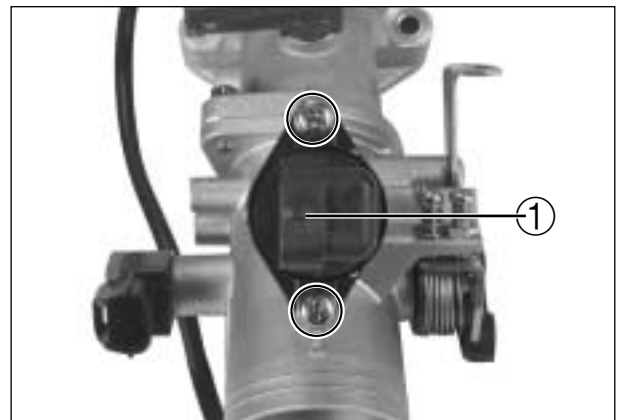

- Remove the IAP sensor ②.
- Remove the fuel injector ③.

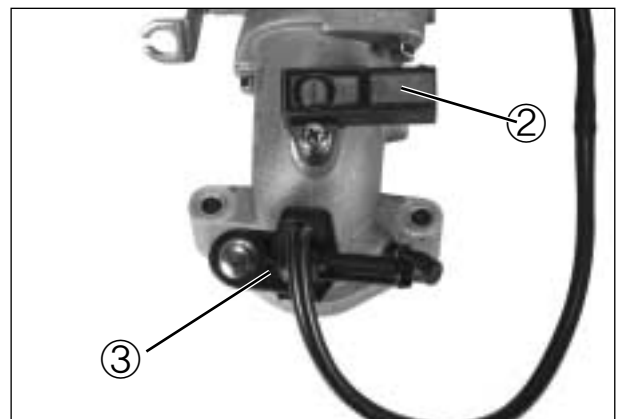

- Remove the intake pipe ④ and O-ring from the intake pipe and throttle body ⑤.



5-9 FUEL SYSTEM AND THROTTLE BODY

⚠ CAUTION

Never remove the idle screw①.

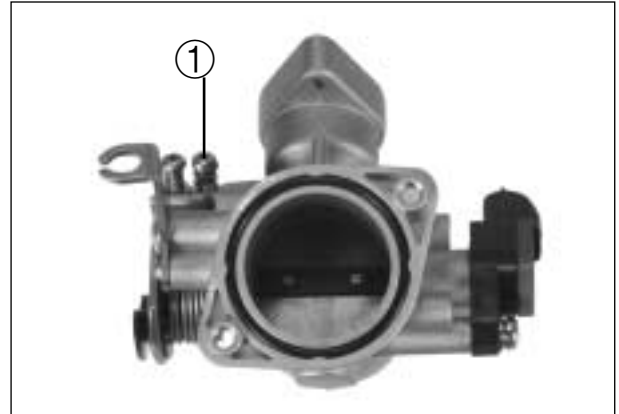

⚠ CAUTION

Never remove the TP sensor②.

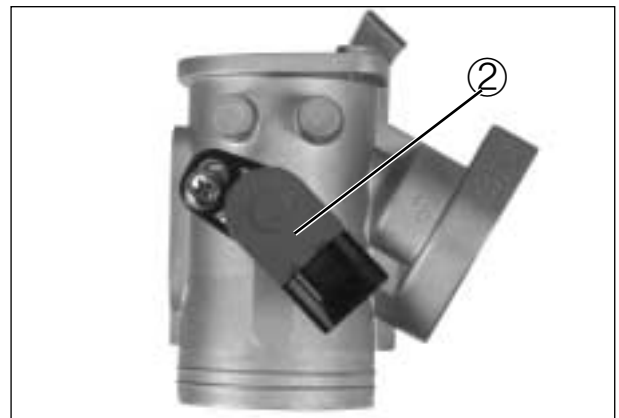

⚠ CAUTION

Never remove the throttle valve③.

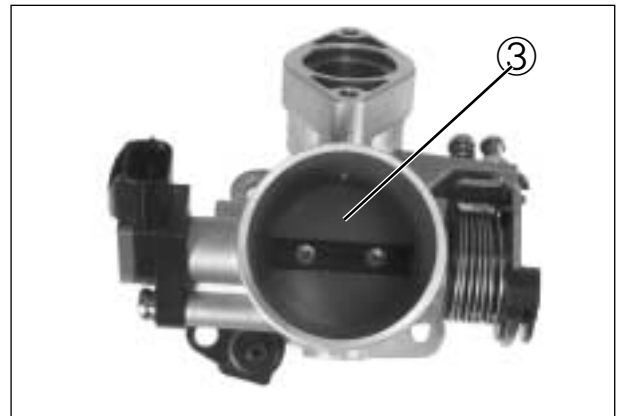

⚠ CAUTION

Never remove the throttle lever stopper screw④.

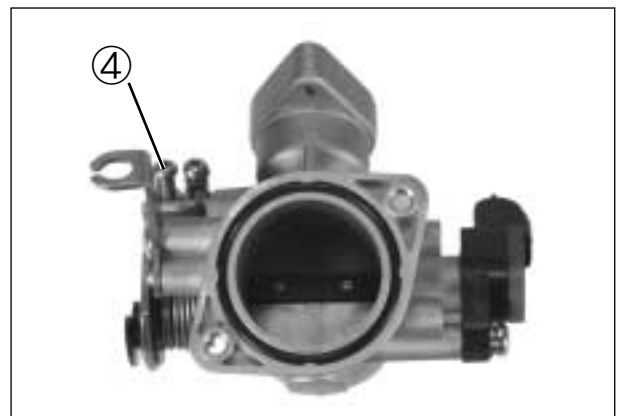

CLEANING

- Clean all passageways with a spray-type throttle body cleaner and blow dry with compressed air.

WARNING

Some throttle body cleaning chemicals, especially dip-type soaking solutions, are very corrosive and must be handled carefully. Always follow the chemical manufacturer's instructions on proper use, handling and storage.

- Check following items any damage or clogging.

* Throttle shaft bushing and seal	* Fuel injector
* Throttle valve	* O-ring
* Idle adjust screw	* Throttle body
* Vacuum hose	* Intake pipe
* Injector seal	

CAUTION

Do not use wire to clean passageways. Wire can damage passageways. If the components cannot be cleaned with a spray cleaner it may be necessary to use a dip-type cleaning solution and allow them to soak. Always follow the chemical manufacturer's body components. Do not apply throttle body cleaning chemicals to the rubber and plastic materials.

INSPECTION

- The ISC solenoid, IAP sensor and TP sensor can be checked without removing it from the throttle body.
- Inspect the ISC solenoid ① . (Refer to page 4-28)
- Inspect the IAP sensor ② . (Refer to page 4-22)
- Inspect the TP sensor ③ . (Refer to page 4-17)

CAUTION

Never remove the TP sensor ③ .

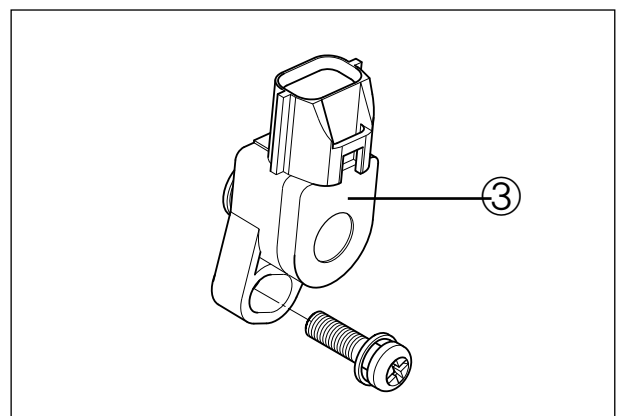
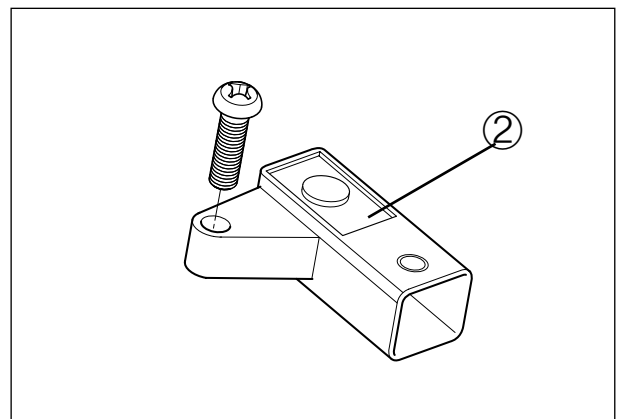
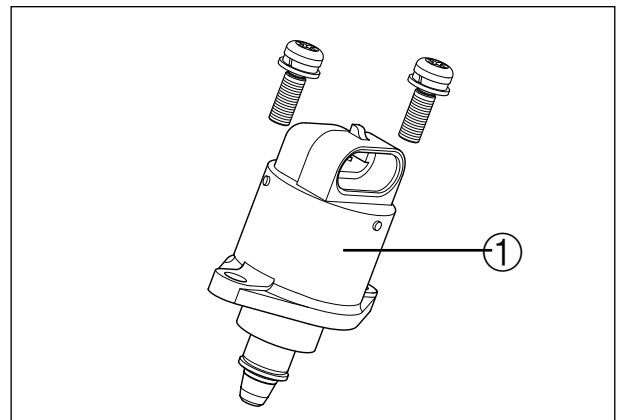

REASSEMBLY

Reassemble the throttle body in the reverse order of disassembly.

Pay attention to the following points :

⚠ CAUTION

Never operate the idle screw ① and throttle lever stopper screw ② to avoid variations of the carburetion setting.

- Apply thin coat of the engine oil to the new O-rings.
- Install the O-rings ③ to the throttle body and intake pipe.

⚠ CAUTION

Replace the O-ring with a new ones.

- Install the O-ring ④ to fuel injector.
- Apply thin coat of the engine oil to the new O-ring.
- Install the fuel injector by pushing them straight to throttle body.

⚠ CAUTION

Replace the O-ring with the new one. Never turn the injector while pushing it.

- Tighten the fuel injector bolt ⑤ to the specified torque.

🔧 Fuel injector bolt

: 6 ~ 8 N · m (0.6 ~ 0.8 kgf · m)

- Tighten the IAP sensor bolt ⑥ to the specified torque.

🔧 IAP sensor bolt

: 6 ~ 8 N · m (0.6 ~ 0.8 kgf · m)

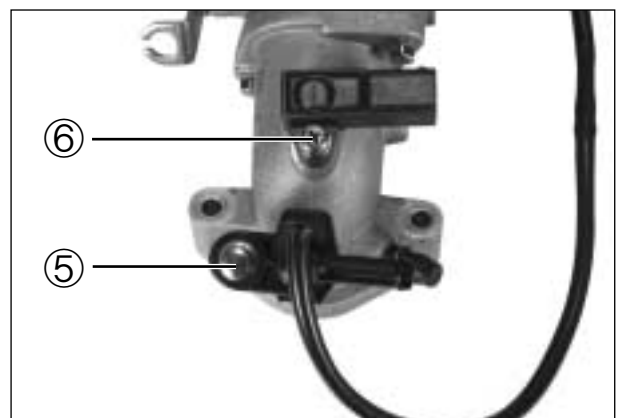
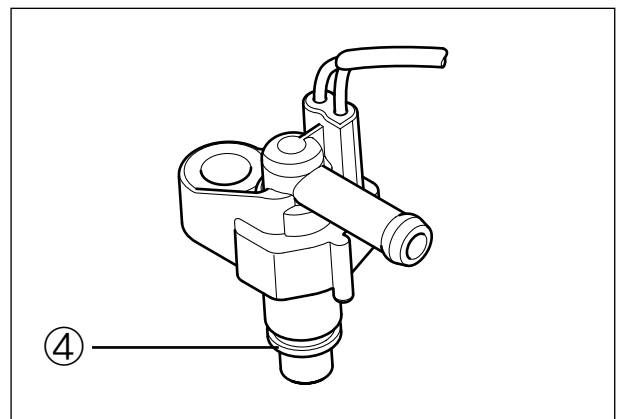
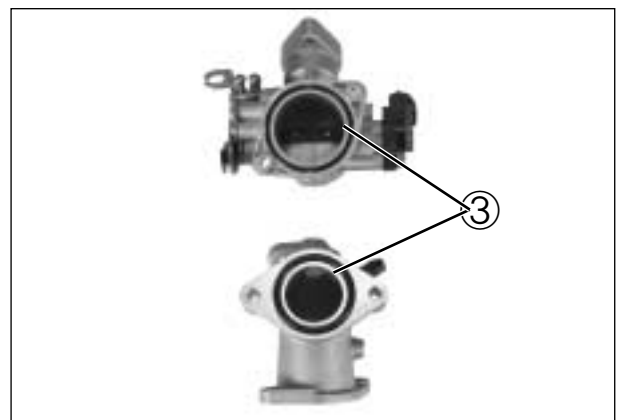
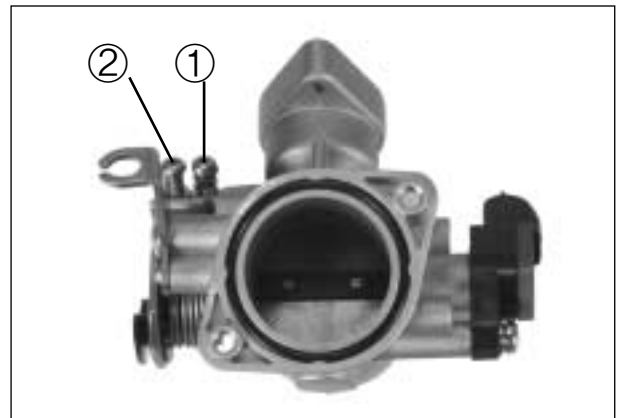

- Tighten the ISC solenoid bolt to the specified torque.

 **ISC solenoid bolt**
: 6 ~ 8 N · m (0.6 ~ 0.8 kgf · m)

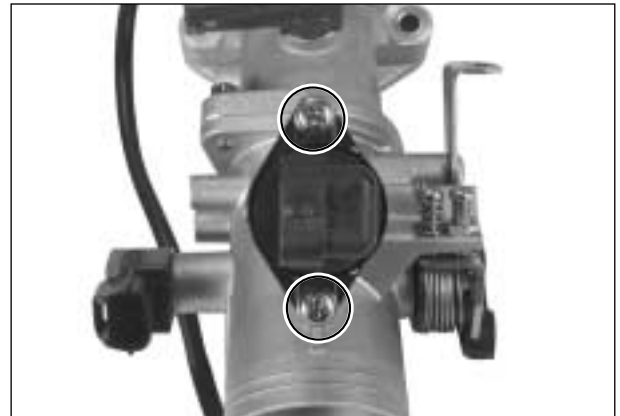

INSTALLATION

Installation is the reverse order of removal.

THROTTLE CABLE ADJUSTMENT

 Refer to page 2-11

FUEL INJECTOR REMOVAL

- Lift and support the side cover with the side cover stay. (Refer to page 2-2)
- Disconnect the injector coupler.
- Remove the fuel injector hose. (Refer to page 5-7)
- Remove the fuel injector. (Refer to page 5-8)



FUEL INJECTOR INSPECTION

- The fuel injector can be checked without removing it from the throttle body.
- Inspect the fuel injector. (Refer to page 4-29)

FUEL INJECTOR INSTALLATION

- Install the fuel injector. (Refer to page 5-11)

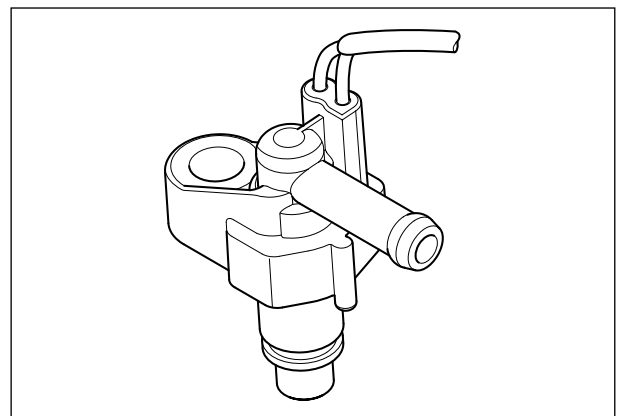

COOLING SYSTEM

CONTENTS

ENGINE COOLANT	6- 1
COOLING CIRCUIT	6- 2
RADIATOR	6- 2
COOLING FAN	6- 5
COOLING FAN THERMO-SWITCH	6- 6
WATER TEMPERATURE SENSOR	6- 8
THERMOSTAT	6- 9
WATER PUMP	6-11

ENGINE COOLANT

At the time of manufacture, the cooling system is filled with a 50 : 50 mixture of distilled water and ethylene glycol anti-freeze.

This 50 : 50 mixture will provide the optimum corrosion protection and excellent heat protection, and will protect the cooling system from freezing at temperatures above -31°C (-24°F).

If the vehicle is to be exposed to temperatures below -31°C (-24°F), this mixing ratio should be increased up to 55% or 60% according to the figure.

Anti-freeze density	Freezing point
50%	-31°C (-24°F)
55%	-40°C (-40°F)
60%	-55°C (-67°F)

 CAUTION	
❖ Use a high quality ethylene glycol base anti-freeze, mixed with distilled water. Do not mix an alcohol base anti-freeze and different brands of anti-freeze.	
❖ Do not put in more than 60% anti-freeze or less than 50%. (Refer to Right figure.)	
❖ Do not use a radiator anti-leak additive.	

50% Engine coolant including reserve tank capacity	
Anti-freeze	0.575 ℓ
Water	0.575 ℓ

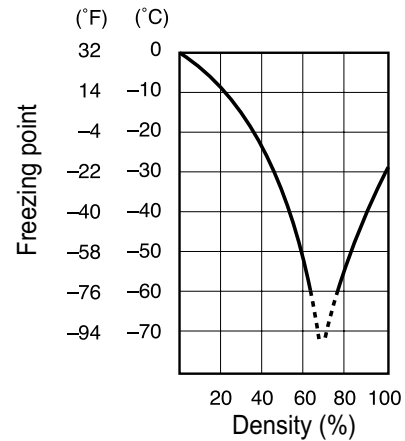

Fig.1 Engine coolant density-freezing point curve.

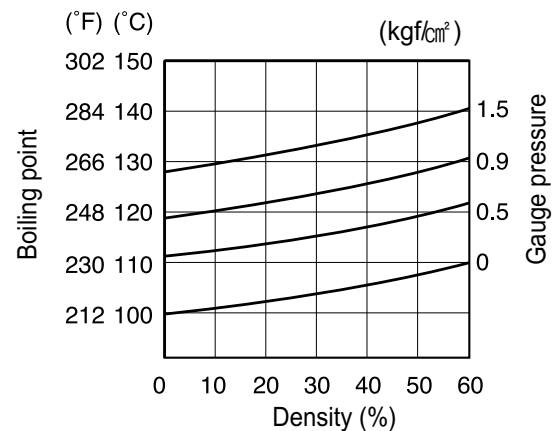
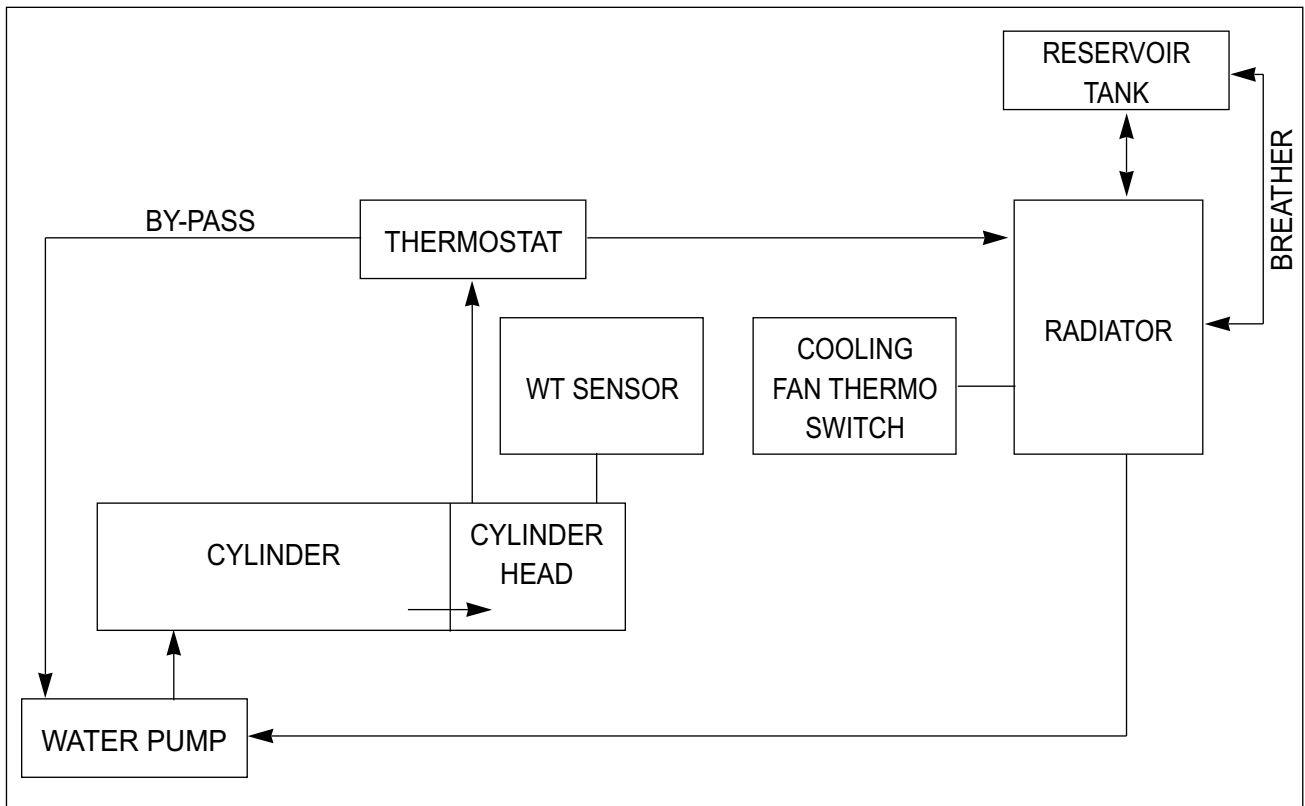

Fig.2 Engine coolant density-boiling point curve.

WARNING

- ❖ You can be injured by scalding fluid or steam if you open the radiator cap when the engine is hot. After the engine cools, wrap a thick cloth around cap and carefully remove the cap by turning it a quarter turn to allow pressure to escape and then turn the cap all the way off.
- ❖ The engine must be cool before servicing the cooling system.
- ❖ Coolant is harmful ;
 - * If it comes in contact with skin or eyes, flush with water.
 - * If swallowed accidentally, induce vomiting and call physician immediately.
 - * Keep it away from children.

COOLING CIRCUIT



RADIATOR

REMOVAL

- Remove the front leg shield and leg shield cover. (Refer to page 8-3 ~ 6)
- Drain engine coolant by removing the drain bolt ①.

- Disconnect the cooling fan thermo-switch lead wire coupler ②.
- Disconnect the radiator outlet hose ③ and radiator cap hose ④.

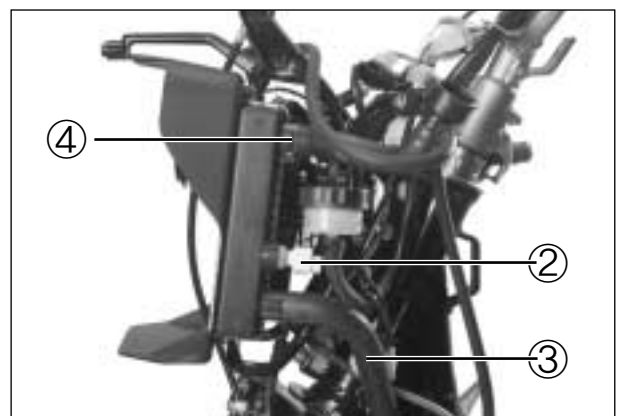
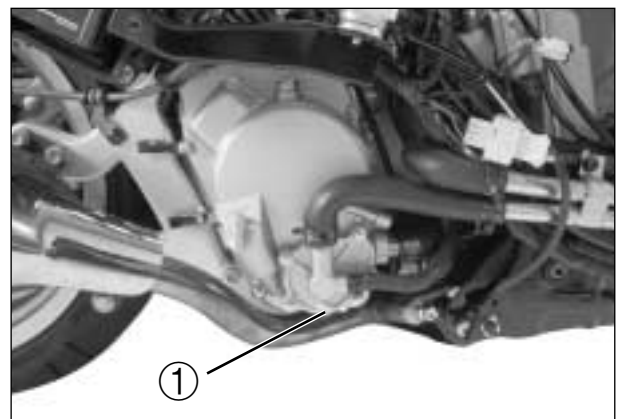

6-3 COOLING SYSTEM

- Remove the radiator inlet hose ①.

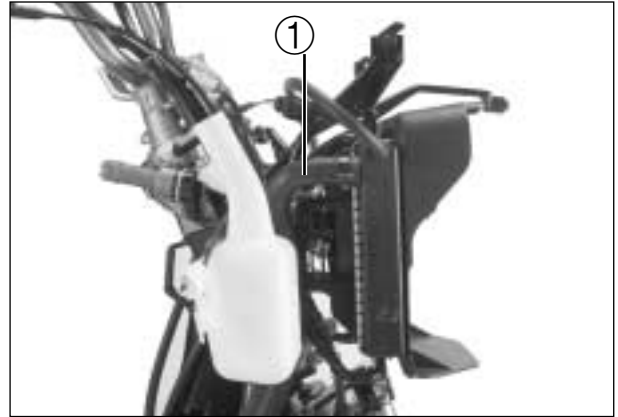

- Disconnect reserve tank hose ②.
- Disconnect the cooling fan motor lead wire coupler ③.

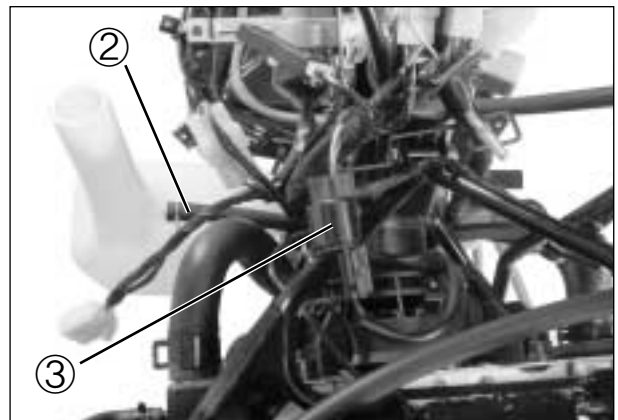

- Remove the radiator by the mounting bolts.

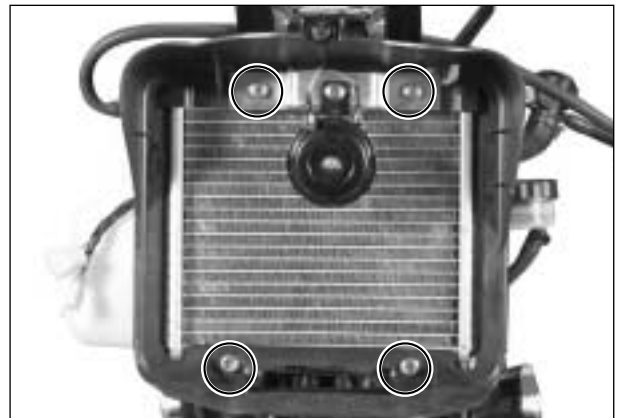
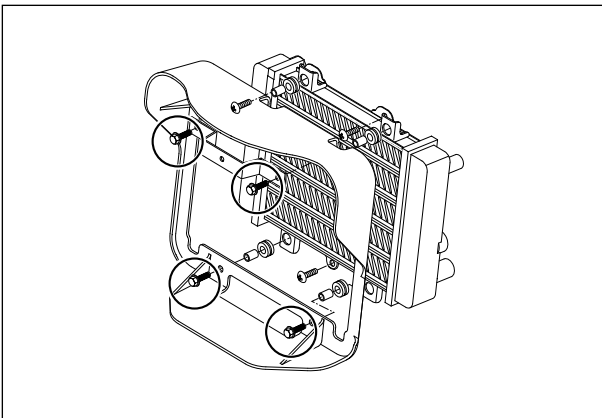

⊙ INSPECTION AND CLEANING

Road dirt or trash stuck to the fins must be removed. Use of compressed air is recommended for this cleaning.



Fins bent down or dented can be repaired by straightening them with the blade of a small screwdriver.

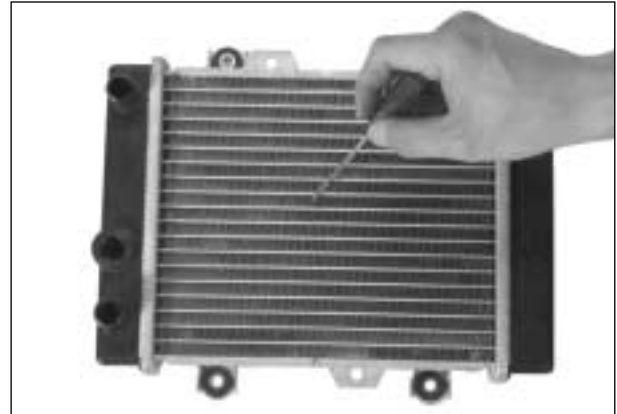

⊙ INSPECTION OF WATER HOSE

- Remove the lower leg rear shield. (Refer to page 8-7)

Any water hose found in a cracked condition or flattened or water leaked must be replaced.

Any leakage from the connecting section should be corrected by proper tightening.

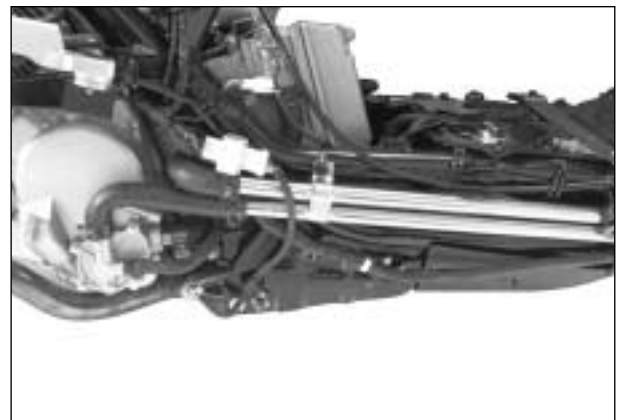

⊙ REMOUNTING

The radiator reassembly can be performed in the reverse order of disassembly procedures.

However, the following points must be observed in the reassembly operation.

- Install the radiator with the specified torque.

🔧 Radiator mounting bolt

: 8 ~ 12 N · m (0.8 ~ 1.2 kgf · m)

* Pour engine coolant Refer to page 2-16

* Bleed air from the cooling circuit . . . Refer to page 2-17

⊙ RADIATOR RESERVOIR TANK

🔧 REMOVAL / REMOUNTING

- Remove the reservoir tank mounting bolts and disconnect the siphon hose from the reservoir tank and drain engine coolant.
- Install the reservoir tank in the reverse order of removal.
- Fill the reservoir tank to the upper level line.

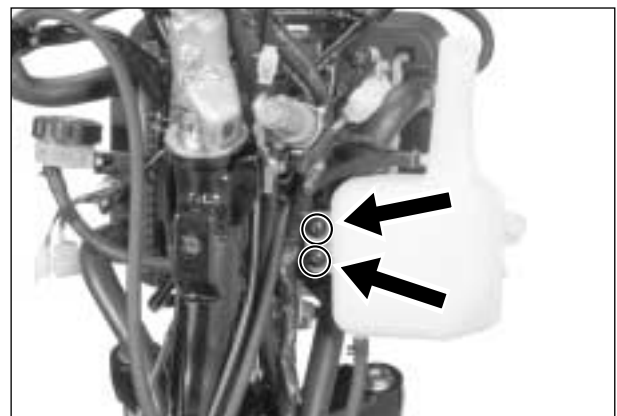

COOLING FAN

⊙ INSPECTION

- Remove the front leg shield and leg shield cover. (Refer to page 8-3 ~ 6)
 - Disconnect the cooling fan motor lead wire coupler ① and its thermo-switch lead wire coupler.
- Test the cooling fan motor for load current with an ammeter connected as shown in the illustration.

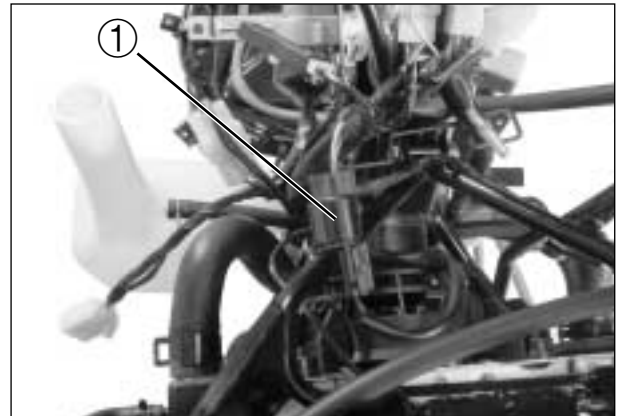

The voltmeter is for making sure that the battery applies 12 volts to the motor. With the motor with electric motor fan running at full speed, the ammeter should be indicating not more than 5 amperes. If the fan motor does not turn, replace the motor assembly with a new one.

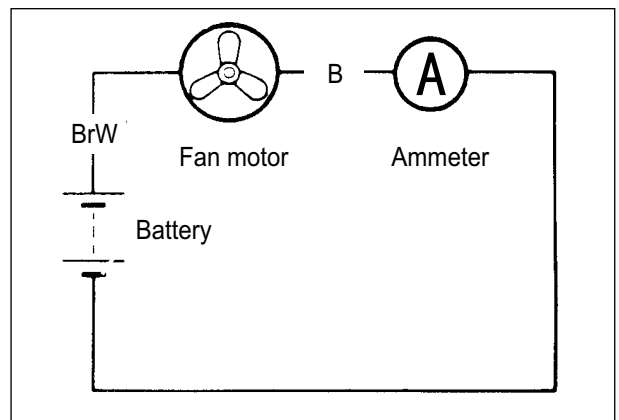

NOTE

When making above test, it is not necessary to remove the cooling fan.

⊙ REMOVAL

- Drain engine coolant. (Refer to page 2-16)
- Remove the front leg shield and leg shield cover. (Refer to page 8-3 ~ 6)
- Remove the radiator. (Refer to page 6-3)
- Disconnect the cooling fan thermo-switch ②.
- Remove the cooling fan.

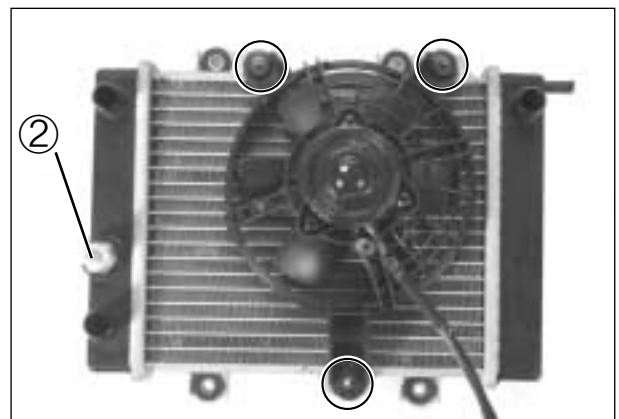

⊙ INSTALLATION

- Install the cooling fan to the radiator.

🔧 Cooling fan mounting bolt
: 8 ~ 12 N · m (0.8 ~ 1.2 kgf · m)

🔧 Cooling fan motor mounting bolt
: 8 N · m (0.8 kgf · m)

- Install the radiator.
- Route the radiator hoses properly.
- Pour engine coolant. (Refer to page 2-16)
- Bleed air from the cooling circuit. (Refer to page 2-17)
- Install the front leg shield and leg shield cover.

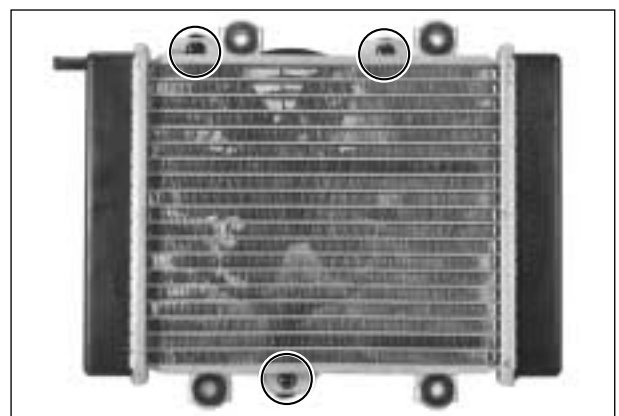

COOLING FAN THERMO-SWITCH

The cooling fan is secured behind the radiator by three bolts and is automatically controlled by the thermo-switch. The thermo-switch remains open when the temperature of the engine coolant is low, but closes when the temperature reaches approximately 78°C (172°F) setting the cooling fan in motion.

REMOVAL

- Remove the front leg shield and leg shield cover. (Refer to page 8-3 ~ 6)
- Drain engine coolant. (Refer to page 2-16)
- Disconnect the cooling fan thermo-switch lead wire coupler.
- Remove the cooling fan thermo-switch①.

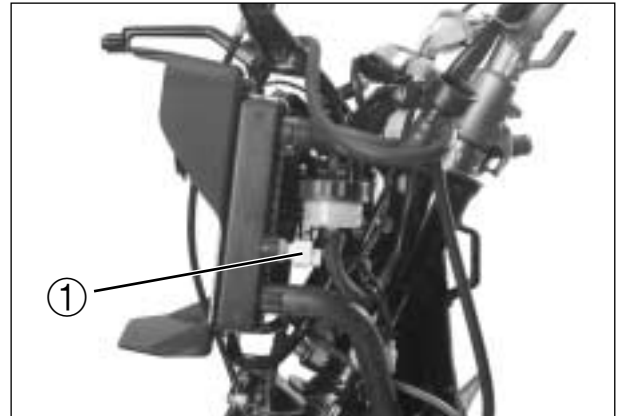

INSPECTION

- Check the thermo-switch closing or opening temperatures by testing it at the bench as shown in the figure. Connect the thermo-switch ① to a circuit tester and place it in the OIL contained in a pan, which is placed on a stove.
- Heat the oil to raise its temperature slowly and read the column thermometer ② when the switch closes or opens.

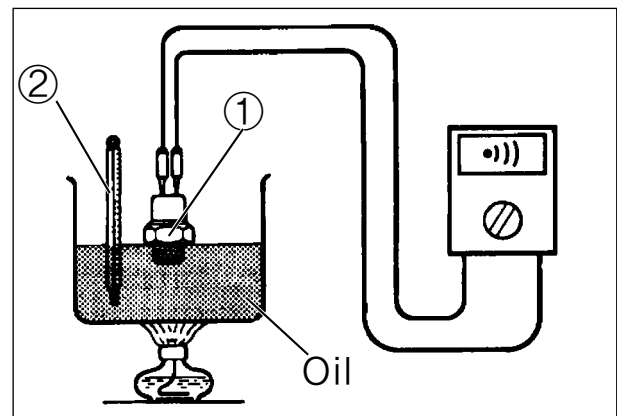

Cooling fan thermo-switch operating temperature	Standard
OFF → ON	Approx. 85°C (185°F)
ON → OFF	Approx. 78°C (172°F)

 Multi circuit tester set : 09900-25008

CAUTION

- ❖ Take special care when handling the thermo-switch. It may cause damage if it gets a sharp impact.
- ❖ Do not contact the cooling fan thermo-switch ① and the column thermometer ② with a pan.

⊙ INSTALLATION

Install the cooling fan thermo-switch in the reverse order of removal.

Pay attention to the following points :

- Install a new O-ring ① and apply engine coolant to the O-ring.
- Tighten the cooling fan thermo-switch to the specified torque.



Cooling fan thermo-switch

: 13 N · m (1.3 kgf · m)

- Pour engine coolant. (Refer to page 2-16)
- Bleed air from the cooling circuit.
(Refer to page 2-17)
- Install the front leg shield and leg shield cover.

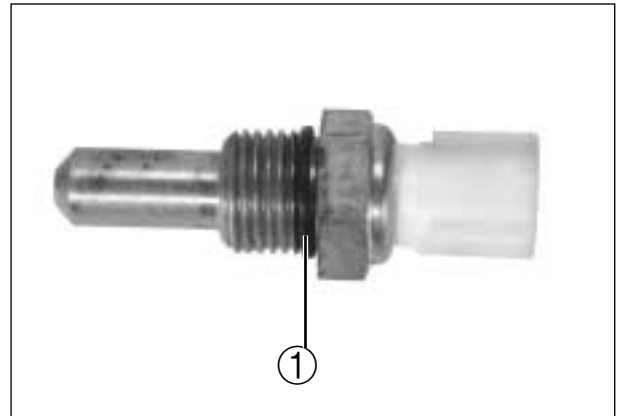

WATER TEMPERATURE SENSOR

REMOVAL

- Lift and support the side cover with the side cover stay. (Refer to page 2-2)
- Drain engine coolant. (Refer to page 2-16)
- Disconnect the WT (Water Temperature) sensor lead wire coupler.
- Remove the WT sensor ①.

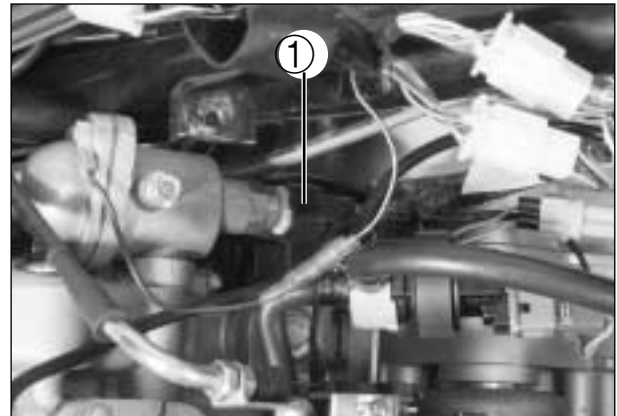

INSPECTION

- Check the engine coolant temperature by testing it at the bench as shown in the figure. Connect the WT sensor ① to a circuit tester and place it in the WATER contained in a pan, which is placed on a stove.
- Heat the water to raise its temperature slowly and read the column thermometer ② and the ohmmeter.

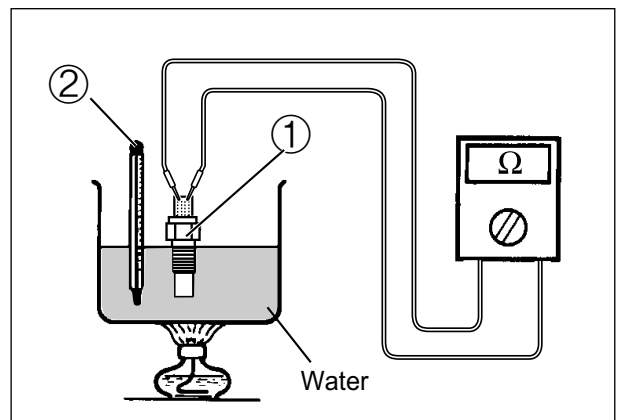

WT sensor resistance	
Engine Coolant Temp.	Resistance (To ECU)
0 °C (32 °F)	Approx. 5.790 KΩ
20 °C (68 °F)	Approx. 2.450 KΩ
40 °C (104 °F)	Approx. 1.148 KΩ
60 °C (140 °F)	Approx. 0.586 KΩ
80 °C (176 °F)	Approx. 0.322 KΩ

TOOL Multi circuit tester set : 09900-25008

If the resistance noted to show infinity or too much different resistance value, replace the WT sensor with a new one.

CAUTION

- Take special care when handling the WT sensor. It may cause damage if it gets a sharp impact.
- Do not contact the WT sensor ① and the column thermometer ② with a pan.

INSTALLATION

Install the WT sensor in the reverse order of removal. Pay attention to the following points :

- Install a new O-ring ③ and apply engine coolant to the O-ring.
- Tighten the WT sensor to the specified torque.

WT sensor : 18 N · m (1.8 kgf · m)

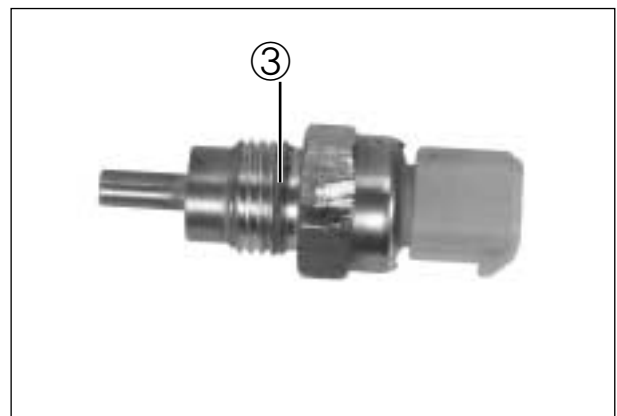

- Pour engine coolant. (Refer to page 2-16)
- Bleed air from the cooling circuit. (Refer to page 2-17)

THERMOSTAT

REMOVAL

- Lift and support the side cover with the side cover stay. (Refer to page 2-2)
- Drain engine coolant. (Refer to page 2-16)
- Place a rag under the thermostat case.
- Remove the thermostat case cap.



- Remove the thermostat ①.

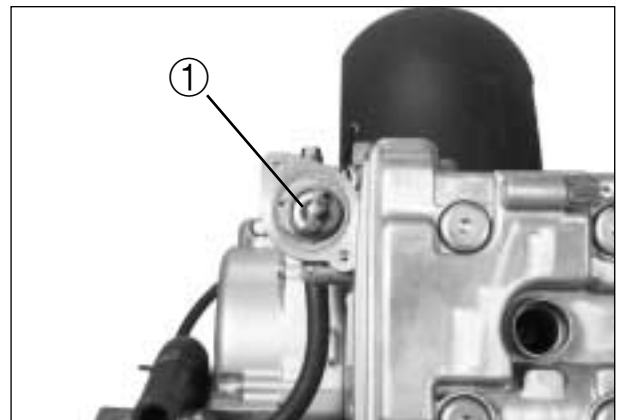

INSPECTION

Inspect the thermostat pellet for signs of cracking. Test the thermostat at the bench for control action, in the following manner.

- Pass a string between flange, as shown in the photograph.
- Immerse the thermostat in the WATER contained in a beaker, as shown in the illustration. Note that the immersed thermostat is in suspension. Heat the water by placing the beaker on a stove ② and observe the rising temperature on a thermometer ③.
- Read the thermometer just when opening the thermostat. This reading, which is the temperature level at which the thermostat valve begins to open, should be within the standard value.

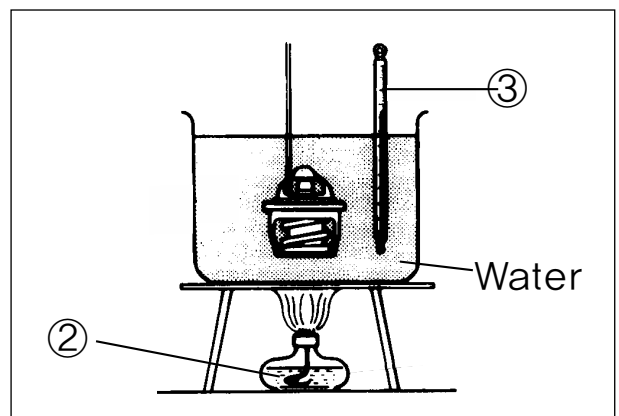

Thermostat valve operation temperature	Standard
Valve opening	76°C (169°F)
Valve full open	90°C (194°F)
Valve closing	71°C (160°F)

- Keep on heating the water to raise its temperature.
- Just when the water temperature reaches specified value, the thermostat valve should have lifted by at least 8.0 mm (0.32 in).

Thermostat valve lift Ⓐ	Standard
	Over 8.0 mm at 90°C (Over 0.32 in at 194°F)

- A thermostat failing to satisfy either of the two requirements, start-to-open temperature and valve lift, must be replaced with a new one.

⊙ INSTALLATION

Install the thermostat in the reverse order of removal. Pay attention to the following points :

- Apply engine coolant to the rubber seal on the thermostat.

- Install the thermostat ① .

⚠ CAUTION
<ul style="list-style-type: none"> ❖ When installing the thermostat, align the protection ② of thermostat with the pawl ③ of the thermostat case. ❖ The jiggle valve ④ of the thermostat faces upside.

- Install the thermostat case cap ② .
- Tighten the thermostat case cap bolts to the specified torque.

🔧 Thermostat case cap bolt
: 8 ~ 12 N · m (0.8 ~ 1.2 kgf · m)

- Pour engine coolant. (Refer to page 2-16)
- Bleed air from the cooling circuit. (Refer to page 2-17)

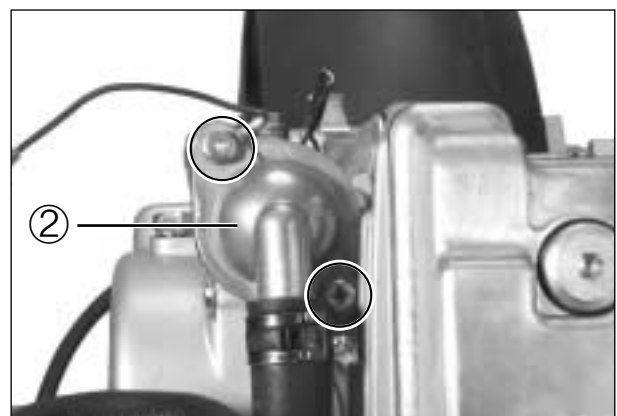
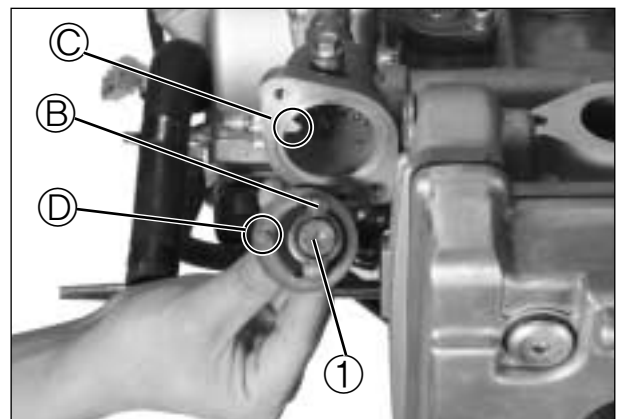
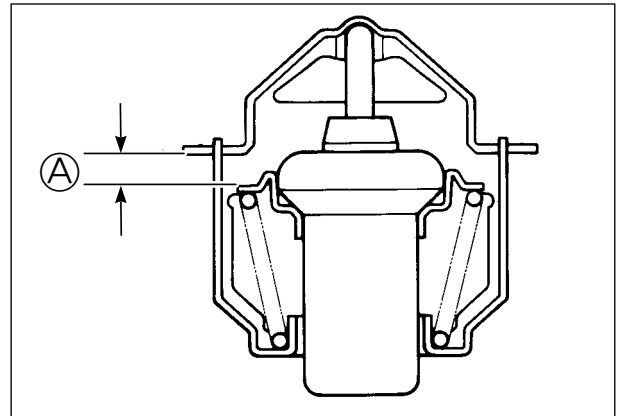

WATER PUMP

⊙ REMOVAL AND DISASSEMBLY

- Drain engine coolant. (Refer to page 2-16)
- Disconnect the water hose ① .
- Remove the water pump case ② .

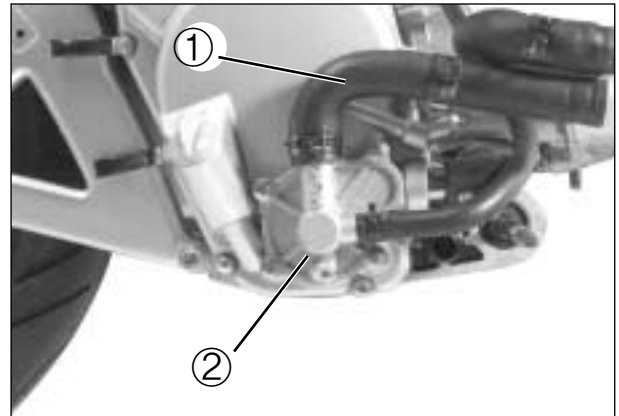

- Remove the O-ring ③ of the water pump case.

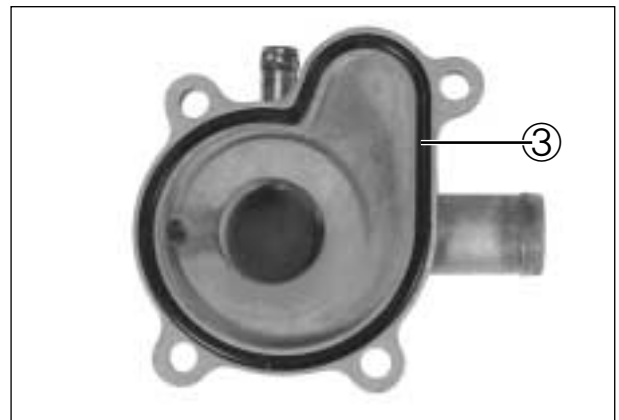

- Remove the magneto cover ④ .

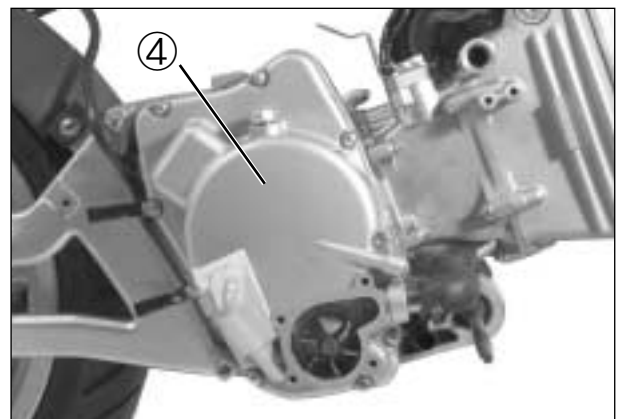

- Remove the E-ring ⑤ from the impeller shaft.

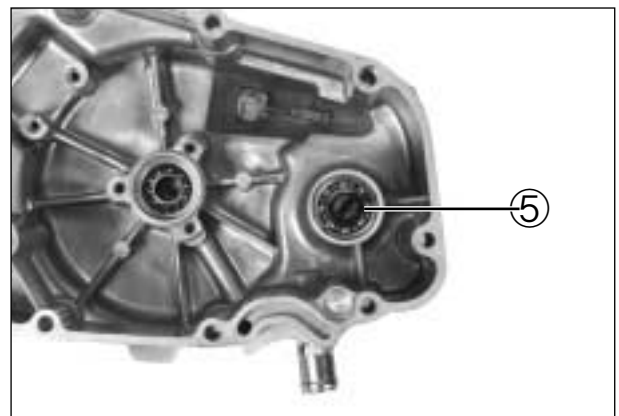

- Remove the impeller① from the other side.



- Remove the circlip ② , magneto cover bearing ③ , oil seal ④ and retainer ⑤ .

 **Bearing remover (12mm) : 09921-20210**

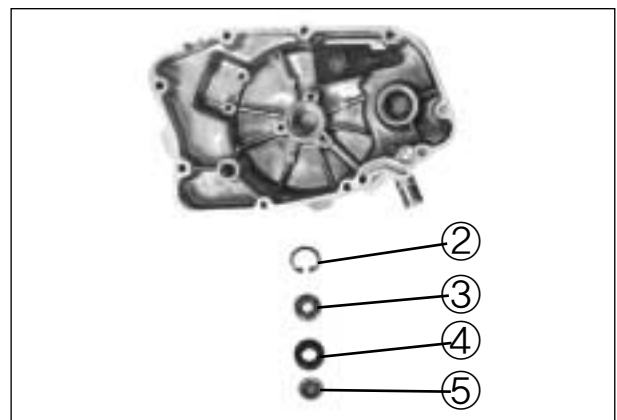

- Remove the water pump case bearing.

 **Bearing remover (12mm) : 09921-20210**

NOTE

If there is no abnormal noise, bearing removal is not necessary.

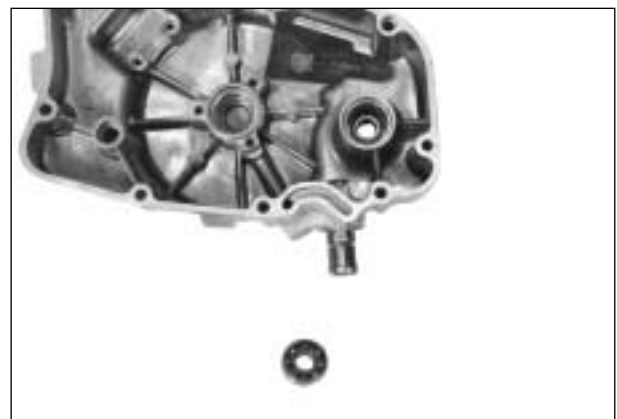

⊙ INSPECTION

▣ BEARING

Inspect the play of the bearing by hand while it is in the water pump case.

Rotate the inner race by hand to inspect abnormal noise and smooth rotation.

Replace the bearing if there is anything unusual.

▣ BEARING CASE

Visually inspect the bearing case for damage.

Replace the magneto cover if necessary.

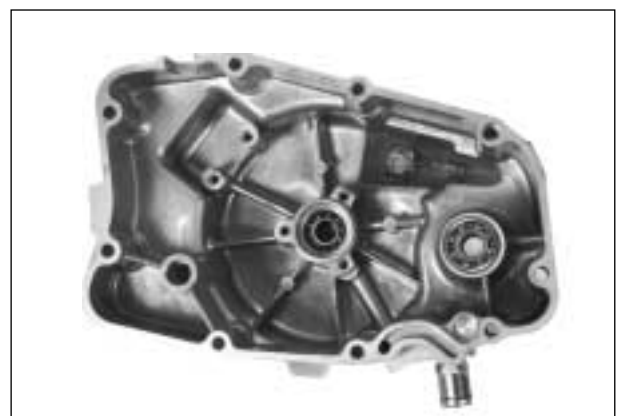

▣ IMPELLER

Visually inspect the impeller and its shaft for damage.



⊙ REASSEMBLY AND REMOUNTING

Install the water pump in the reverse order of removal.

Pay attention to the following points :

- Install the water pump case bearing.

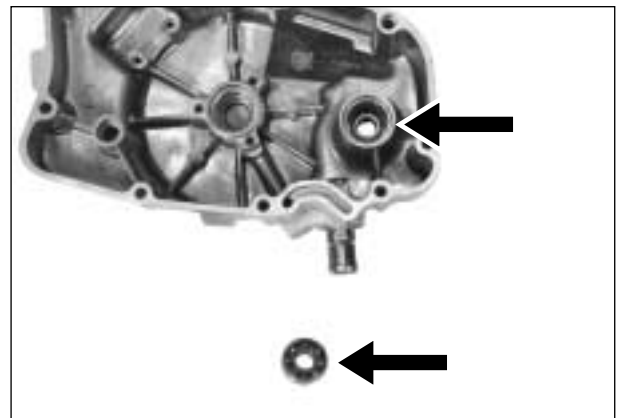

- Install the retainer ①, oil seal ②, magneto cover bearing ③ and circlip ④.

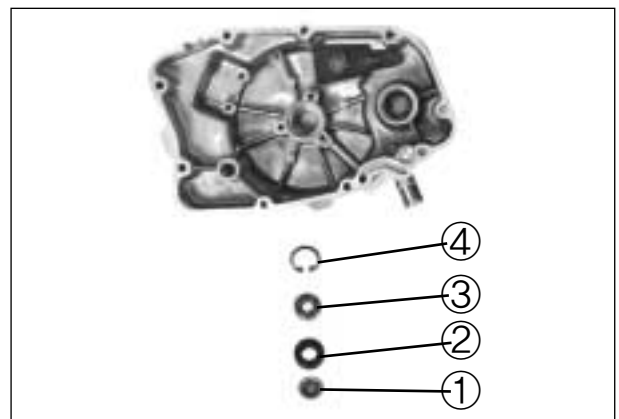

- Apply **SUPER GREASE "A"** to the impeller shaft.

 **SUPER GREASE "A"**

- Install the O-ring and impeller to the water pump body.



- Fix the impeller shaft with the E-ring① .
- Fill the bearing with engine oil until engine oil comes out from the hole of the bearing housing.

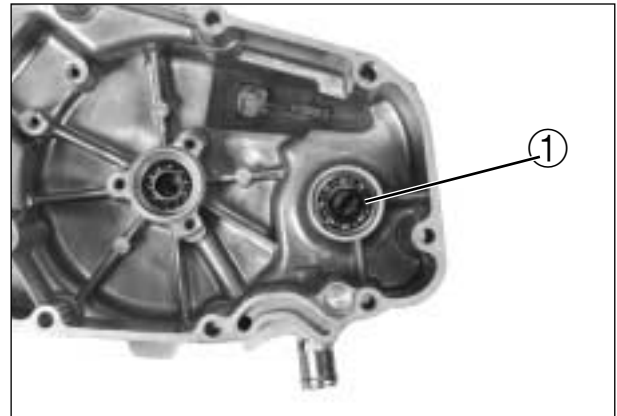

- Apply engine coolant to the O-ring② .
- Install a new O-ring.

 CAUTION
<p>Use a new O-ring to prevent engine coolant leakage.</p>

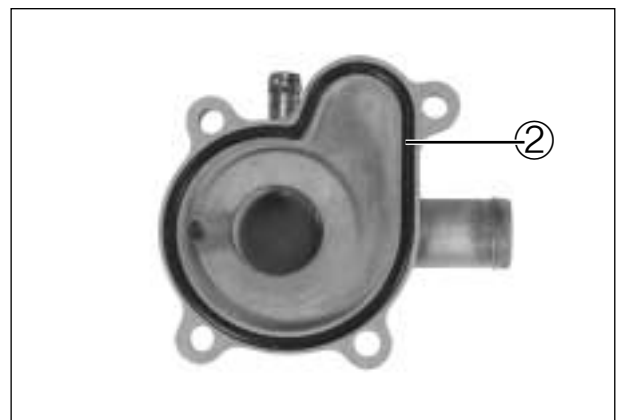

- Install the magneto cover③ .

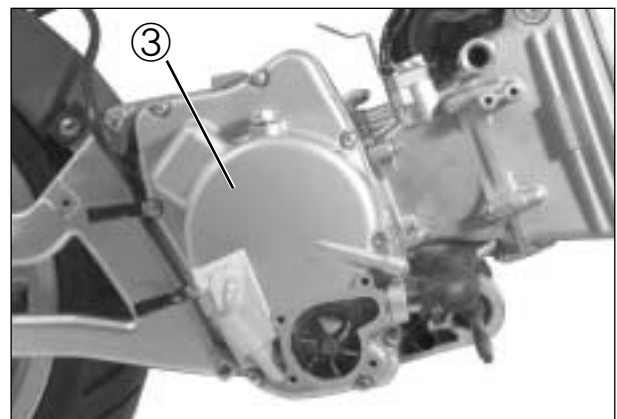

- Install the water pump case④ .
- Connect the water hoses⑤ .
- Pour engine coolant. (Refer to page 2-16)

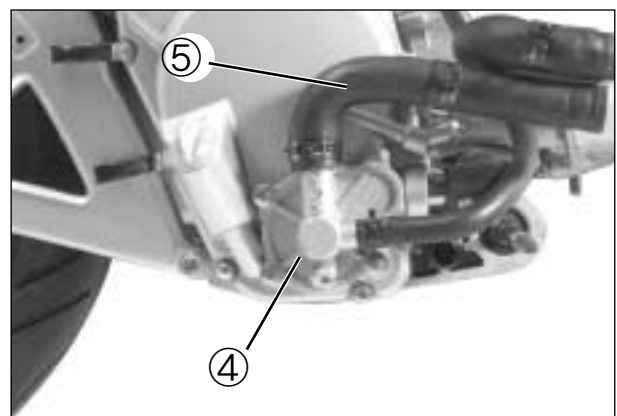

ELECTRICAL SYSTEM

CONTENTS

<i>LOCATION OF ELECTRICAL COMPONENTS</i>	<i>7- 1</i>
<i>IGNITION SYSTEM</i>	<i>7- 3</i>
<i>CHARGING SYSTEM</i>	<i>7- 5</i>
<i>STARTER SYSTEM</i>	<i>7- 8</i>
<i>SWITCHES</i>	<i>7-11</i>
<i>LAMPS</i>	<i>7-12</i>
<i>BATTERY</i>	<i>7-15</i>

LOCATION OF ELECTRICAL COMPONENTS

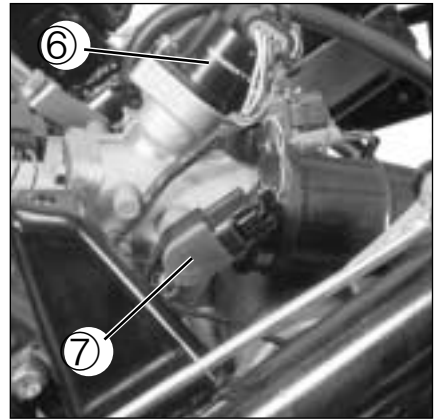
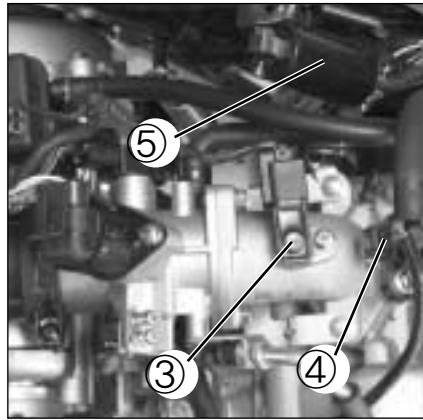
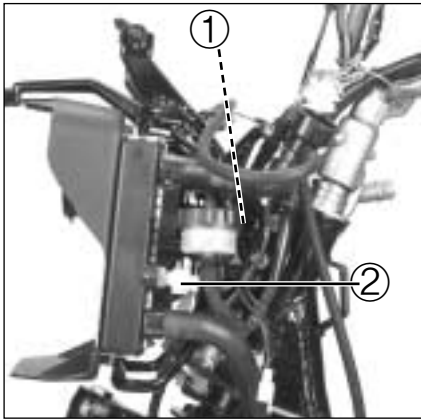

- ① Cooling fan motor
- ② Cooling fan thermo-switch

- ③ IAP sensor
- ④ Fuel injector
- ⑤ Ignition coil

- ⑥ ISC solenoid
- ⑦ TP sensor

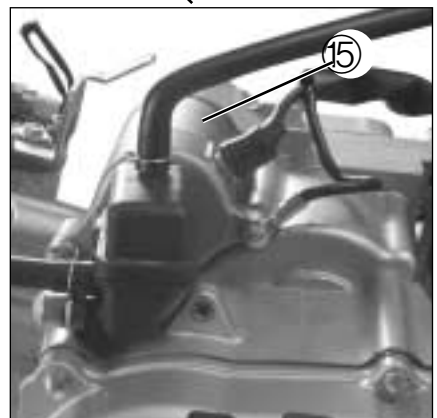
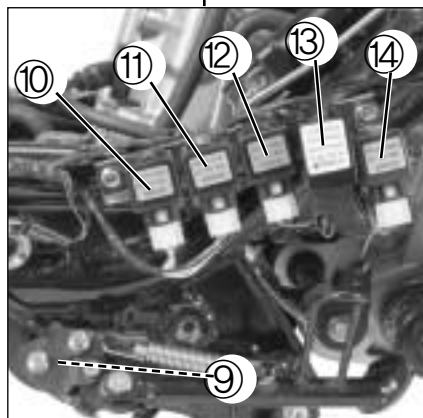
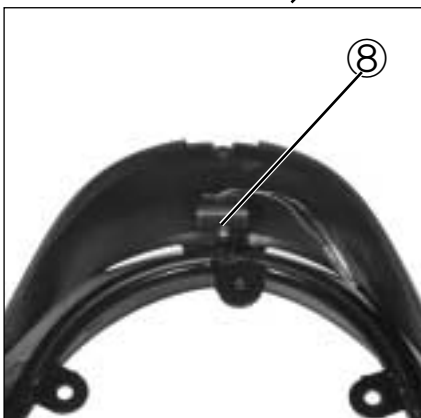
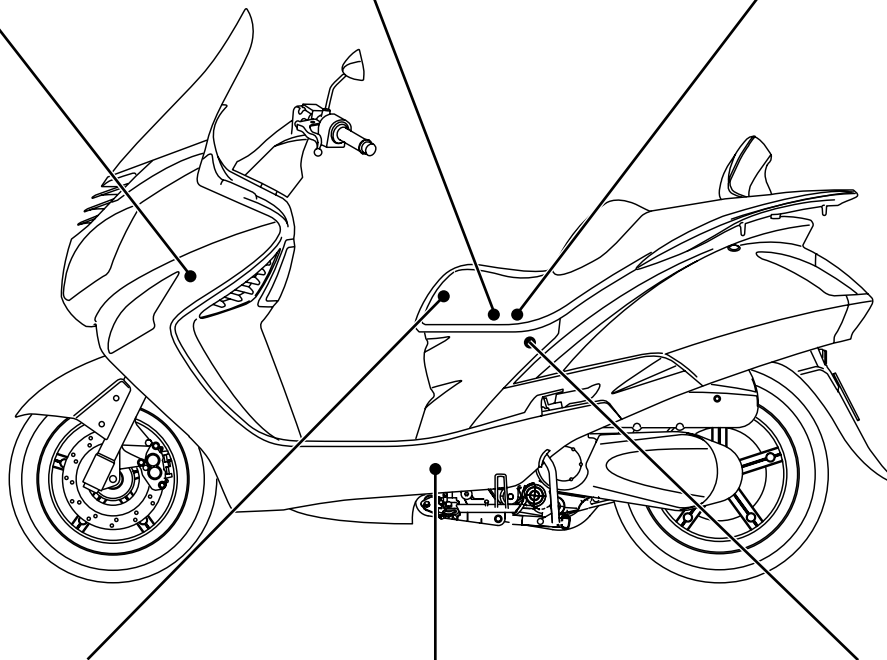

- ⑧ TO sensor

- ⑨ Side stand switch
- ⑩ Head lamp relay
- ⑪ Cooling fan motor relay
- ⑫ Fuel pump relay
- ⑬ Turn signal relay
- ⑭ Main relay

- ⑮ Starter motor

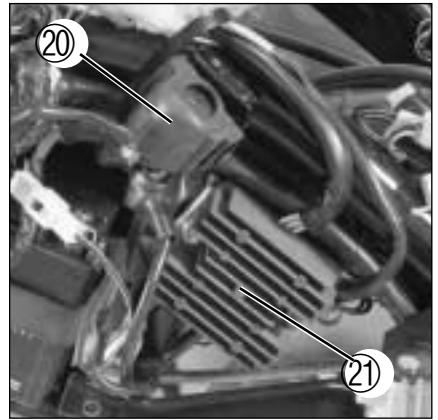
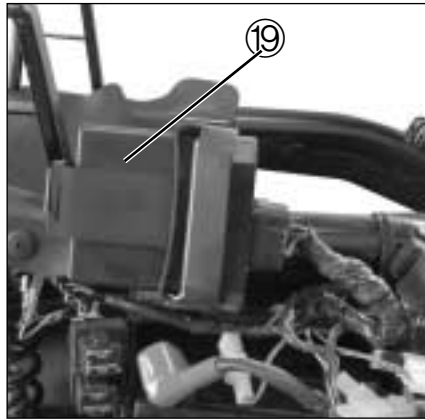
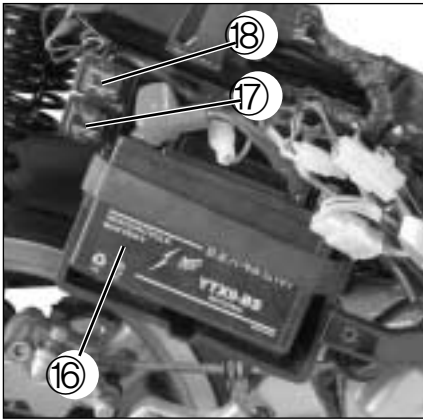

- ⑩ Battery
- ⑪ Main fuse (30A)
- ⑫ Head lamp fuse (15A)

⑬ ECU

- ⑭ Starter motor relay
- ⑮ Regulator / Rectifier

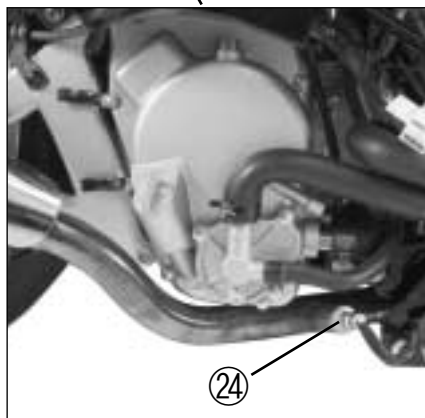
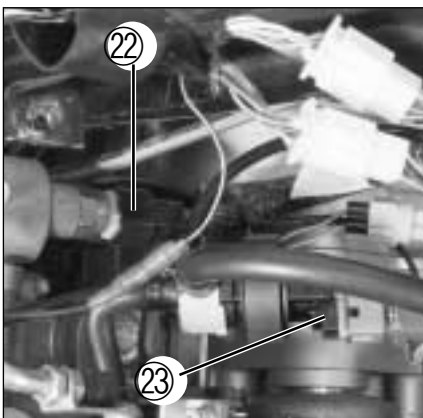
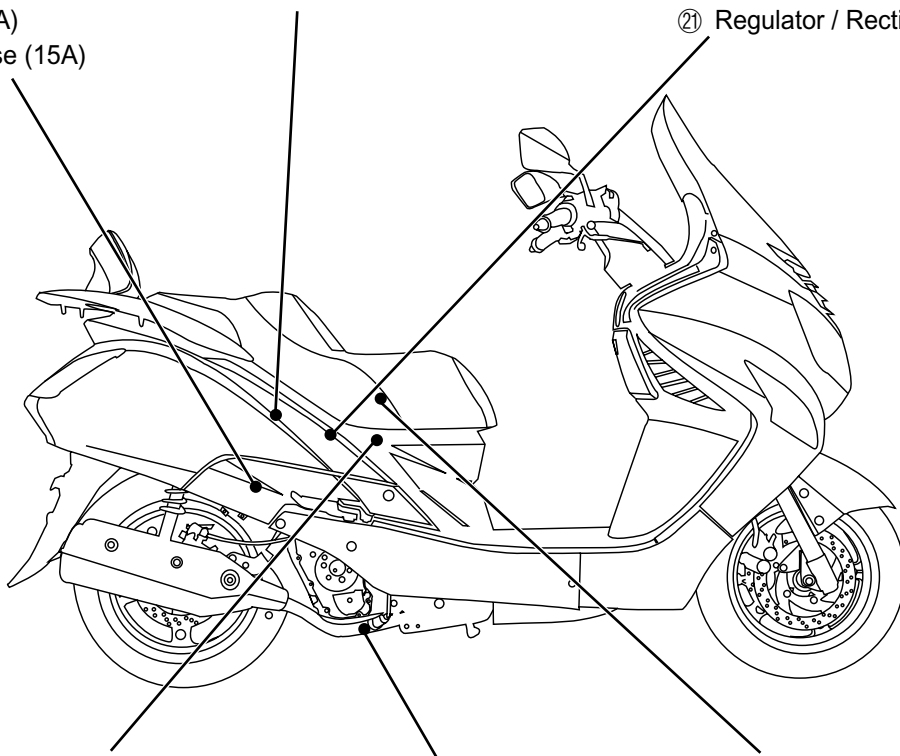

- ⑯ WT sensor
- ⑰ SAV solenoid

- ⑱ Oxygen sensor & Oxygen sensor heater
- ⑲ IAT sensor heater

IGNITION SYSTEM

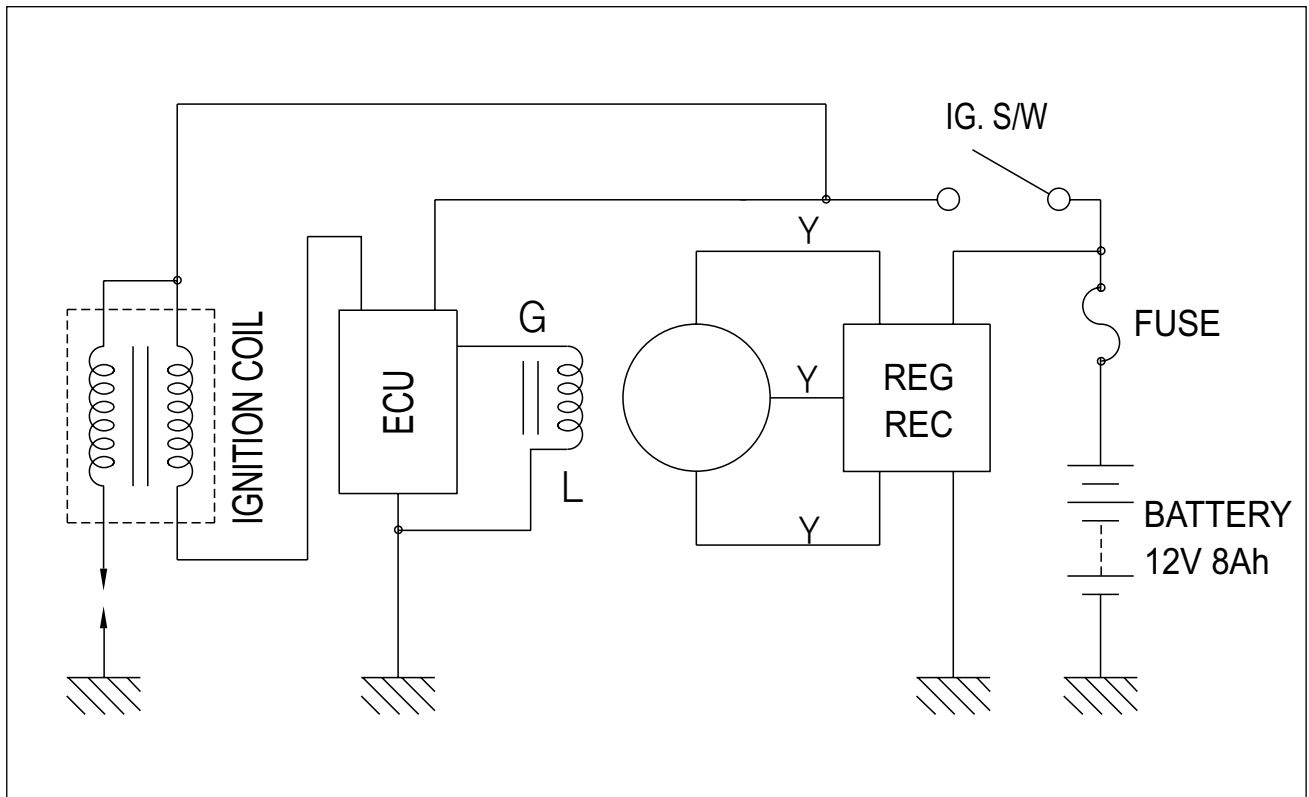

⦿ IGNITION SYSTEM INSPECTION

▣ IGNITION COIL PRIMARY PEAK VOLTAGE INSPECTION

- Lift and support the side cover with the side cover stay. (Refer to page 2-2)
- Disconnect spark plug cap.
- With the spark plug cap connected, place a new spark plug on the engine to ground it.

NOTE

- ❖ Check that all the couplers are connected.
- ❖ Check that the all battery is fully charged.

Measure the ignition coil primary peak voltage using the tester in the following procedure.

- Connect the tester as follows.
 - ⊕ Probe : WL lead wire terminal
 - ⊖ Probe : Ground

NOTE

Do not disconnect the ignition coil / plug cap lead wire couplers.

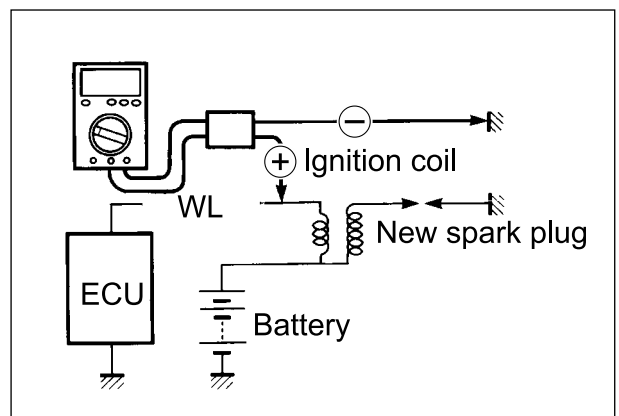

- Turn the ignition switch to the “ \odot ” (ON) position.
- Grasp the front or rear brake lever.
- Press the starter switch and allow the engine to crank for a few seconds, and then measure the ignition coil primary peak voltage.
- Repeat the above procedure a few times and measure the highest ignition coil primary peak voltage.

Ignition coil primary peak voltage 150 V and more

 **Tester knob indication : Voltage (---)**

WARNING

While testing, do not touch the tester probes and spark plug to prevent receiving an electric shock.

If the peak voltage is lower than the specified values, inspect the ignition coil. (Refer to below)

IGNITION COIL RESISTANCE INSPECTION

- Lift and support the side cover with the side cover stay. (Refer to page 2-2)
- Disconnect the ignition coil read wire.

Measure the ignition coil resistance in bolt the primary and secondary windings. If the resistance is not within the standard range, replace the ignition coil with a new one.

IGNITION COIL / PLUG CAP RESISTANCE

Primary	3.5 ~ 5.5 Ω (\oplus Terminal - \ominus Terminal)
Secondary	20 ~ 31 K Ω (Plug cap - \oplus Terminal)

 **Pocket tester : 09900-25002**

 **Tester knob indication : Resistance (Ω)**

PICK-UP COIL RESISTANCE INSPECTION

- Lift and support the side cover with the side cover stay. (Refer to page 2-2)
 - Disconnect the pick-up coil lead wire coupler.
- Measure the resistance between the lead wires and ground. If the resistance is not specified value, the pick-up coil must be replaced.

Pick-up coil resistance 80 ~ 120 Ω (Green - Blue)
 ∞ Ω (Green - Ground)

 **Pocket tester : 09900-25002**

 **Tester knob indication : Resistance (Ω)**

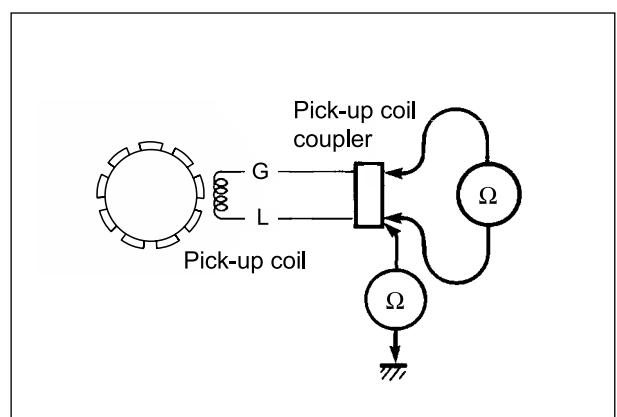
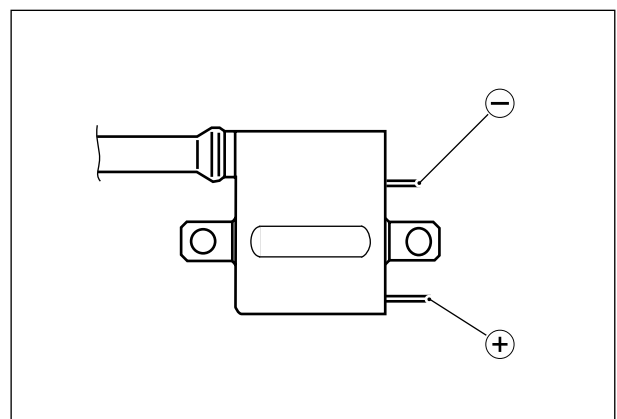
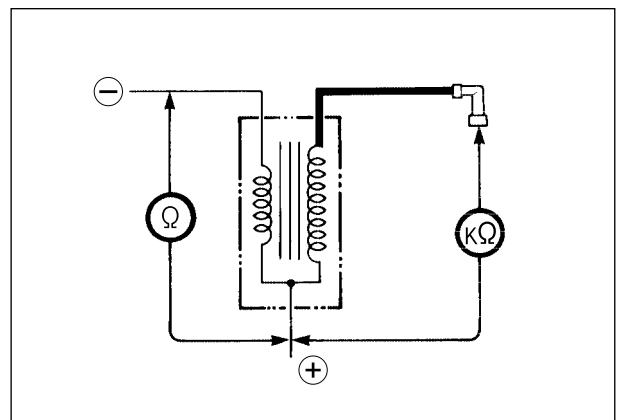
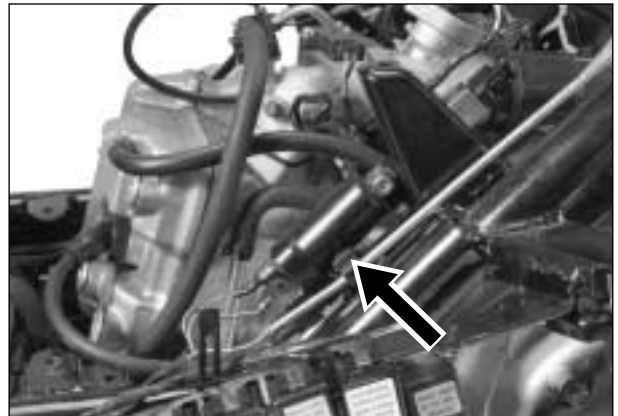

CHARGING SYSTEM

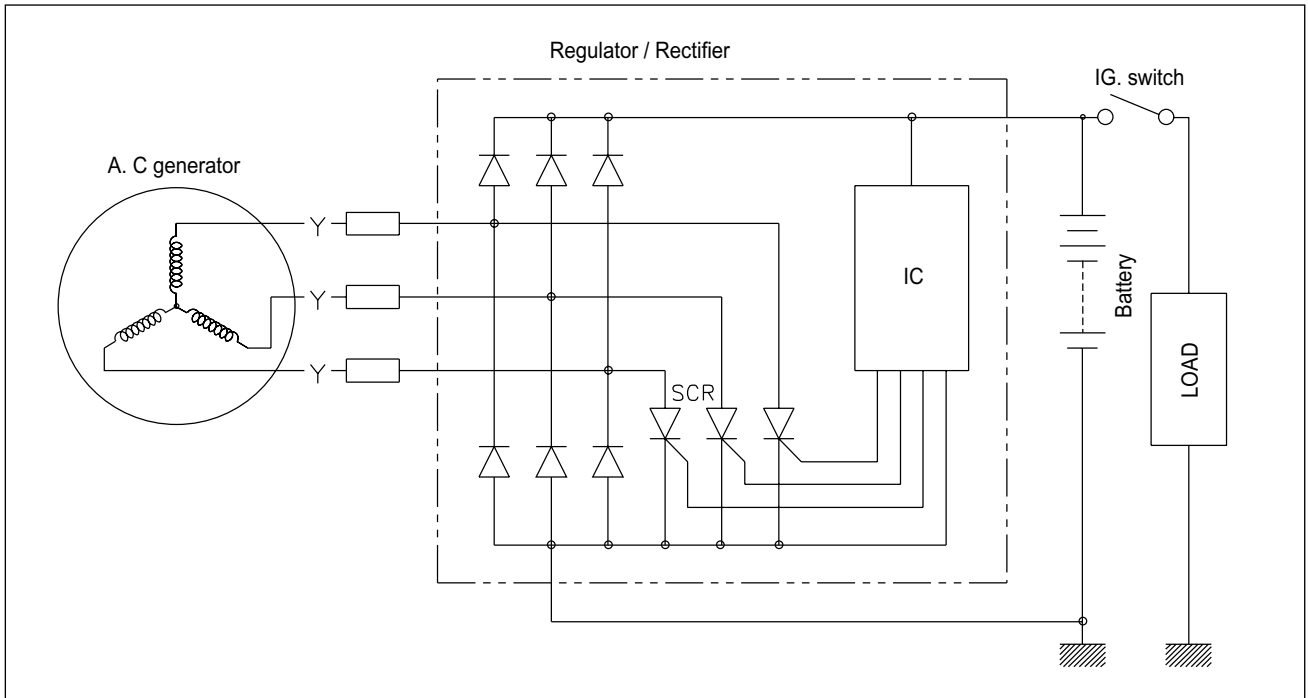

⦿ INSPECTION

▣ CHARGING OUTPUT CHECK

Start the engine and keep it running at 5,000 rpm. Using the pocket tester, measure the DC voltage between the battery terminal ⊕ and ⊖. If the voltage is not within the specified value, check the magneto no-load performance and regulator / rectifier.



	CAUTION
When making this test, be sure that the battery is full-charged condition.	

Standard charge 13.5~15.0V (at 5,000 rpm)

- Pocket tester : 09900-25002**
- Tester knob indication : Voltage (---)**

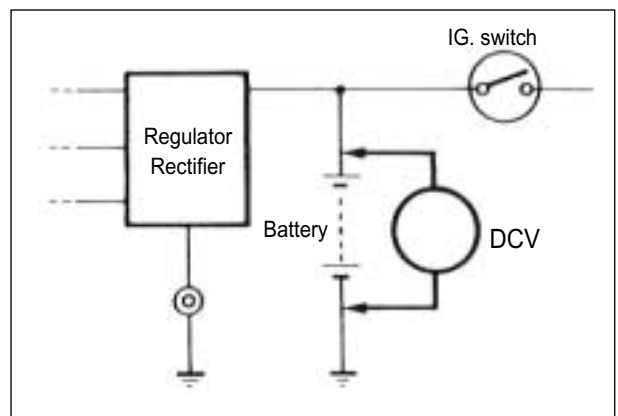

▣ MAGNETO

Using the pocket tester, measure the resistance between the lead wires in the following table.

If the resistance is not within the specified value, replace the stator coil, with a new one.

Stator coil resistance	Standard
Pick-up coil	G-L 80 ~ 120 Ω
Charging coil	Y-Y 0.7 ~ 1.3 Ω

 **TOOL** Pocket Tester : 09900-25002

 Tester knob indication : Resistance (Ω)

CAUTION

When mounting the stator on magneto cover, apply a small quantity of **THREAD LOCK "1324"** to the threaded parts of screws.

 **THREAD LOCK "1324"**

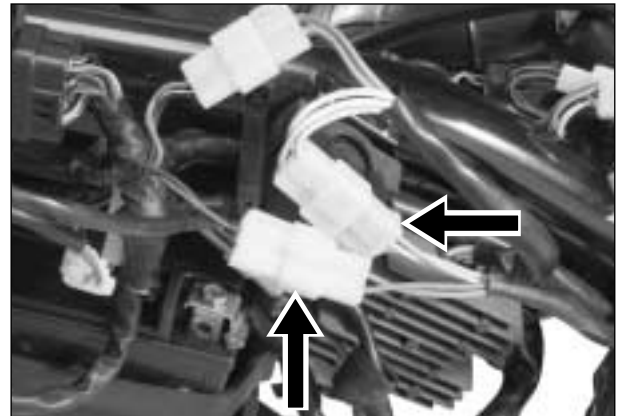

▣ MAGNETO NO-LOAD PERFORMANCE

Disconnect the three lead wires from the magneto terminal.

Start the engine and keep it running at 5,000 rpm.

Using the pocket tester, measure the AC voltage between the three lead wires.

If the voltage is under the specified value, replace the magneto with a new one.

Standard NO-load performance of magneto	Over 70 V (at 5,000 rpm)
--	--------------------------

 **TOOL** Pocket tester : 09900-25002

 Tester knob indication : Voltage (---)

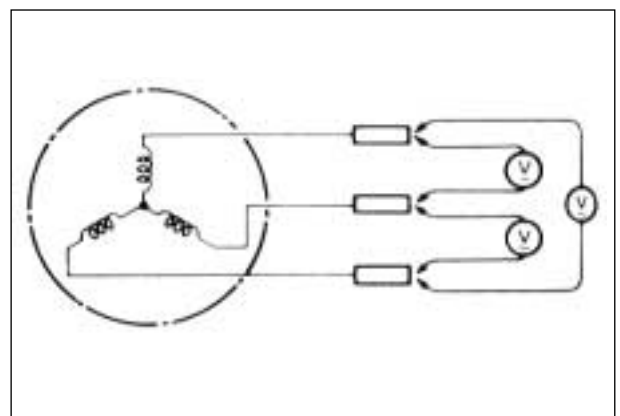

REGULATOR / RECTIFIER

- Remove the 『Seat, side cover & rear fender assembly』. (Refer to page 8-7)
 - Disconnect the regulator / rectifier couplers.
 - Using the pocket tester, measure the resistance between the terminals in the following table.
- If the resistance checked is incorrect, replace the regulator / rectifier.

Unit : MΩ

⊕ Tester probe		①	②	③	④	⑤
Tester probe	①		3~4	3~4	1~2	1~2
	②	3~4		3~4	1~2	1~2
	③	3~4	3~4		1~2	1~2
	④	1~2	1~2	1~2		32kΩ
	⑤	1~2	1~2	1~2	32kΩ	

 **Pocket tester : 09900-25002**

 **Tester knob indication : Resistance (MΩ)**

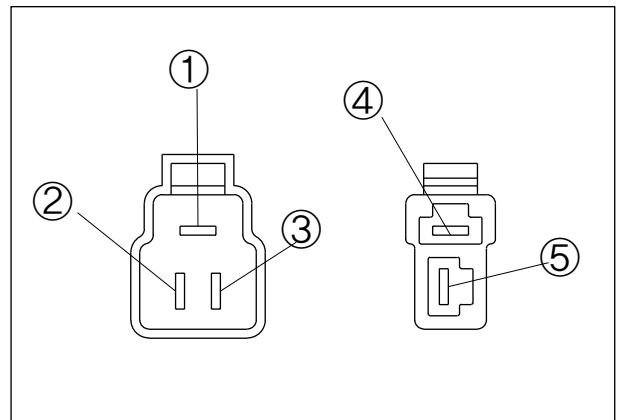
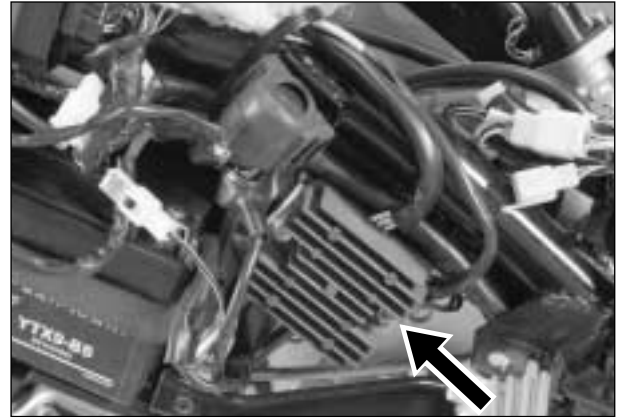

STARTER SYSTEM

◎ STARTER SYSTEM DESCRIPTION

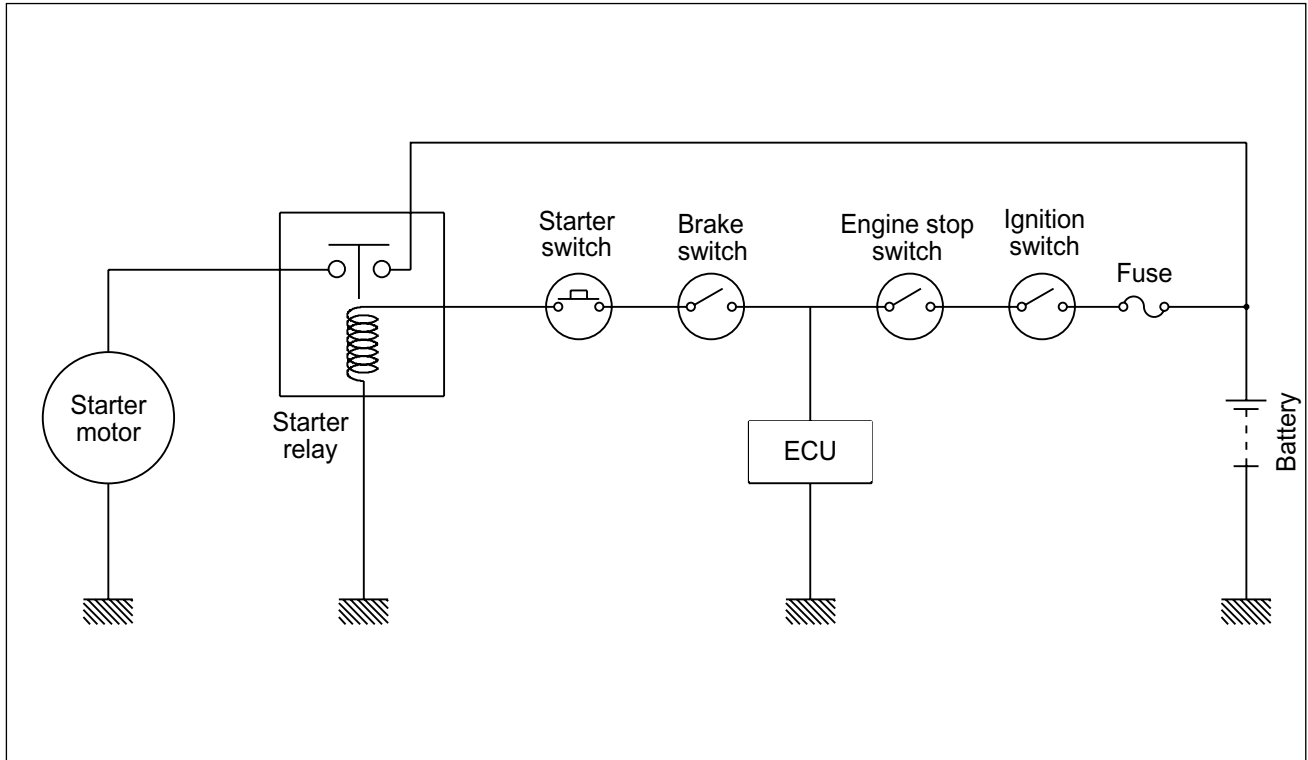

These motorcycles can only start the engine with squeezing the front or rear brake.

⊙ STARTER MOTOR REMOVAL AND DISASSEMBLY

- Disconnect the starter motor lead wire.
- Loosen the starter motor mounting bolts ①.
- Remove the starter motor.

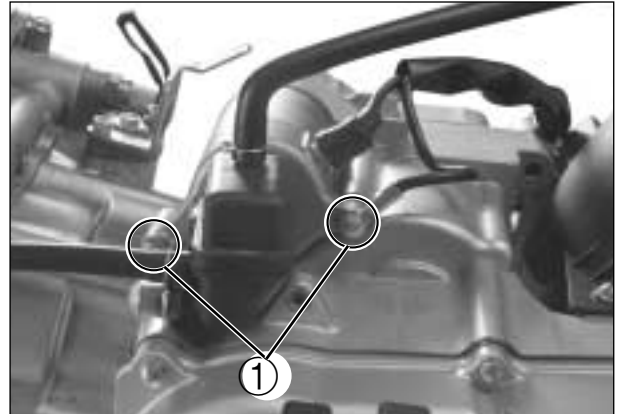

⊙ STARTER MOTOR INSPECTION

▣ CARBON BRUSH

Inspect the carbon brush for abnormal wear, crack or smoothness in the brush holder.

If any damage are found, replace the brush assembly with a new one.

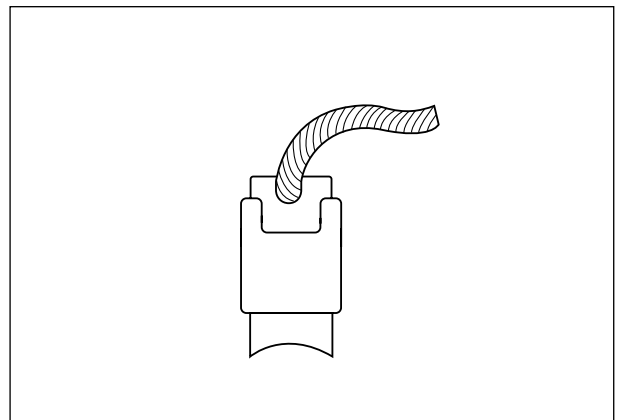

▣ COMMUTATOR

Inspect discoloration, abnormal wear or undercut ① of the commutator.

If the commutator is abnormally worn, replace the armature with a new one.

When surface is discolored, polish it with #400 sand paper and clean it with dry cloth.

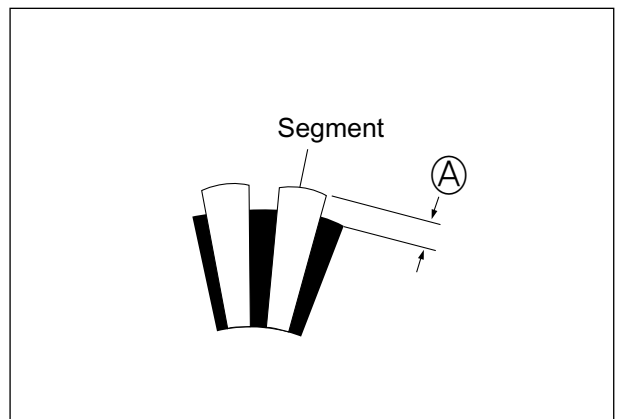

▣ ARMATURE COIL INSPECTION

Check continuity between each segment.

Check continuity between each segment and the armature shaft.

If there is no continuity between the segments or there is continuity between the segment and shaft, replace the starter motor with a new one.

 **Pocket tester : 09900-25002**

 **Tester knob indication**

: Continuity test (•)))

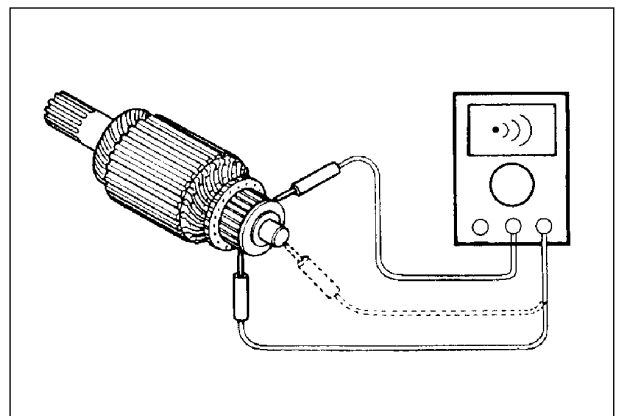

◎ STARTER MOTOR REASSEMBLY

Reassemble the starter motor. Pay attention to the following points :

- Reassembly the starter motor as shown in the illustration.

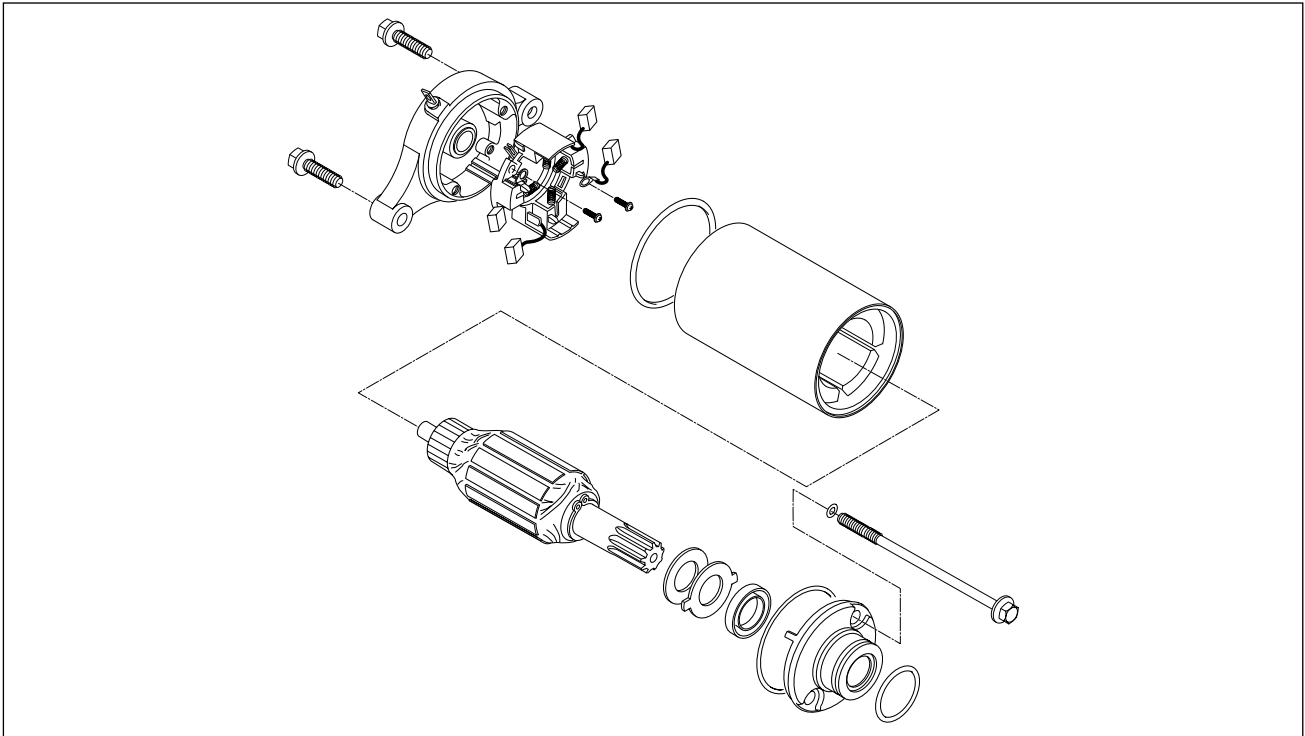

- Align the match mark ① on the housing with the line ② on the housing end.

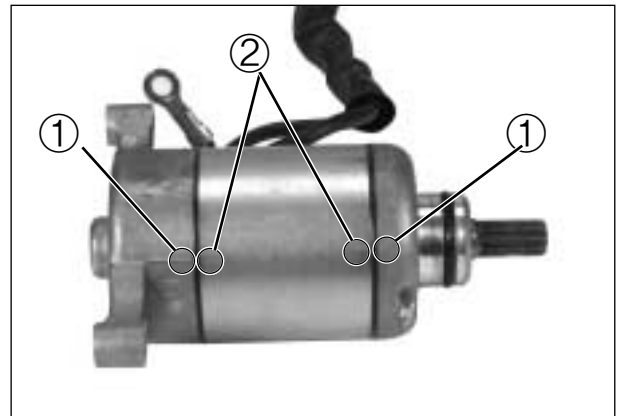

- Apply **SUPER GREASE "A"** to the O-ring ③ and remount the starter motor.

 **SUPER GREASE "A"**

- Tighten the stator motor mounting bolts to the specified torque.

 **Starter motor mounting bolt**
: 8 ~ 12 N · m (0.8 ~ 1.2 kgf · m)

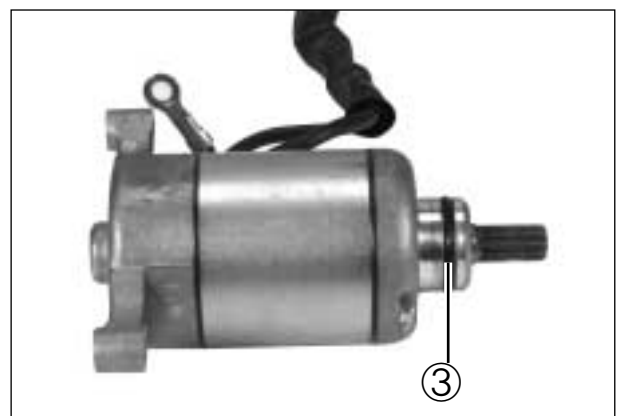



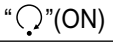
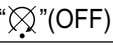

SWITCHES

Measure each switch for continuity using a tester. If any abnormality is found, replace the respective switch assemblies with new ones.

 **Pocket tester : 09900-25002**

IGNITION SWITCH		
	R	O
 (ON)	○-----○	○-----○
 (OFF)		



HAZARD WARNING SWITCH		
	Sb	L
	○-----○	○-----○
		

DIMMER SWITCH			
	YW	Y	W
	○-----○		
	○-----○	○-----○	
	○		

STARTER SWITCH		
	WB	YR
PUSH	○-----○	○-----○
OFF		

FRONT / REAR BRAKE LAMP SWITCH		
	O	WB
ON	○-----○	○-----○
OFF		

HORN SWITCH		
	G	O
PUSH	○-----○	○-----○
OFF		

TURN SIGNAL SWITCH			
	Lg	Sb	B
		○-----○	○-----○
			
	○-----○	○-----○	

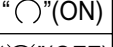
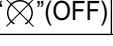
ENGINE STOP SWITCH		
	O	OB
 (ON)	○-----○	○-----○
 (OFF)		

LAMPS

◎ HEAD LAMP

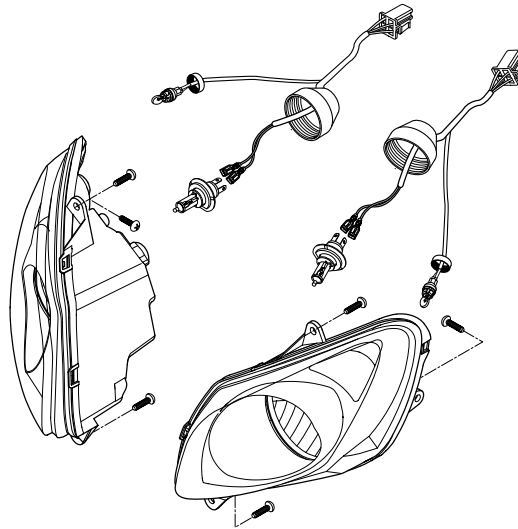

⚠ CAUTION

If you touch the bulb with your bare hands, clean the bulb with a cloth moistened with alcohol or soapy water to prevent premature bulb failure.

▣ HEAD LAMP BULB REPLACEMENT

- Disconnect the head lamp coupler.
- Remove the dust cover ① and socket spring.
- After removing the bulb at socket, replace the new bulb.
- To install the head lamp, reverse the above sequence.

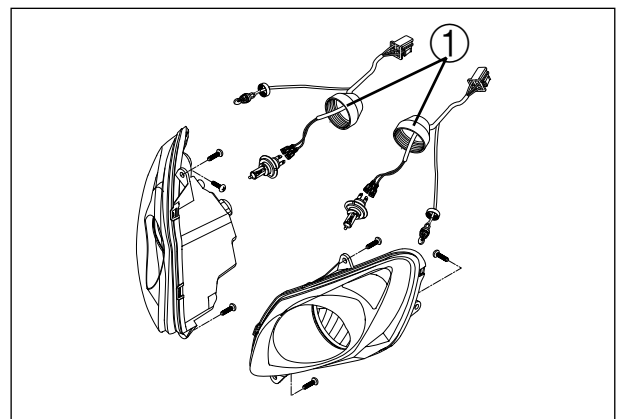

▣ HEAD LAMP BEAM ADJUSTMENT

Turn the adjuster screws ②, ③ of both head lamp bulbs with a screwdriver to adjust as follows : turn CLOCKWISE to lower the beam.
Turn COUNTER-CLOCKWISE to raise the beam.

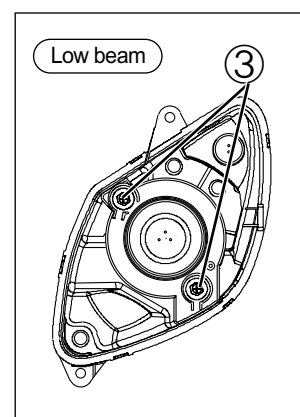
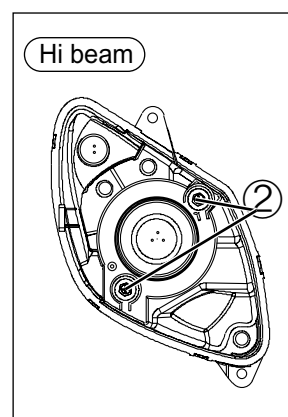

◎ TURN SIGNAL LAMP

▣ TURN SIGNAL LAMP REPLACEMENT

These motorcycles's turn signal lamp is LED (Light Emitting Diode) type.

If any abnormal condition are found, replace the turn signal lamp assembly.

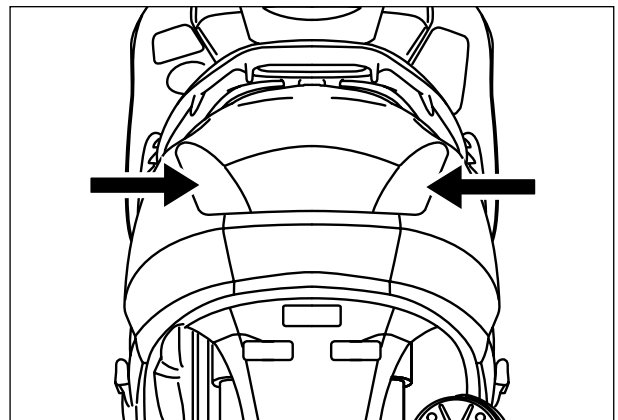
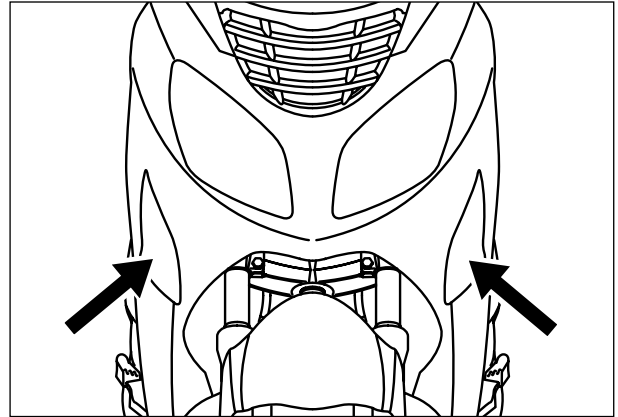

◎ BRAKE / TAIL LAMP



CAUTION

If you touch the bulb with your bare hands, clean the bulb with a cloth moistened with alcohol or soapy water to prevent premature bulb failure.

▣ BRAKE / TAIL LAMP BULB REPLACEMENT

- Lift and support the side cover with the side cover stay. (Refer to page 2-2)
- Turn the socket ① to the counter-clockwise and pull it out at the lamp housing.
- Push in the bulb, turn it to the counter-clockwise and pull it out.
- To fit the replacement bulb, push it in and turn it to the clockwise while pushing.

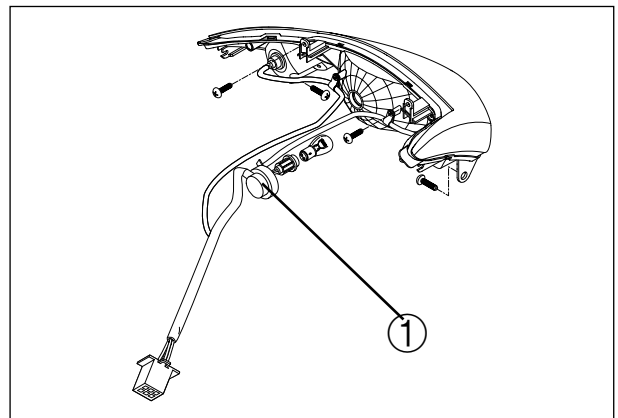

⦿ COMBINATION METER

Remove the combination meter.
Disassemble the combination meter as shown in the illustration.

▣ INSPECTION

Using the pocket tester, check the continuity between lead wires in the following illustration.
If the continuity measured incorrect, replace the respective part.

 **TOOL** Pocket tester : 09900-25002

 **Tester knob indication**
: Continuity test (••••)

CAUTION

When making this test, it is not necessary to remove the combination meter.

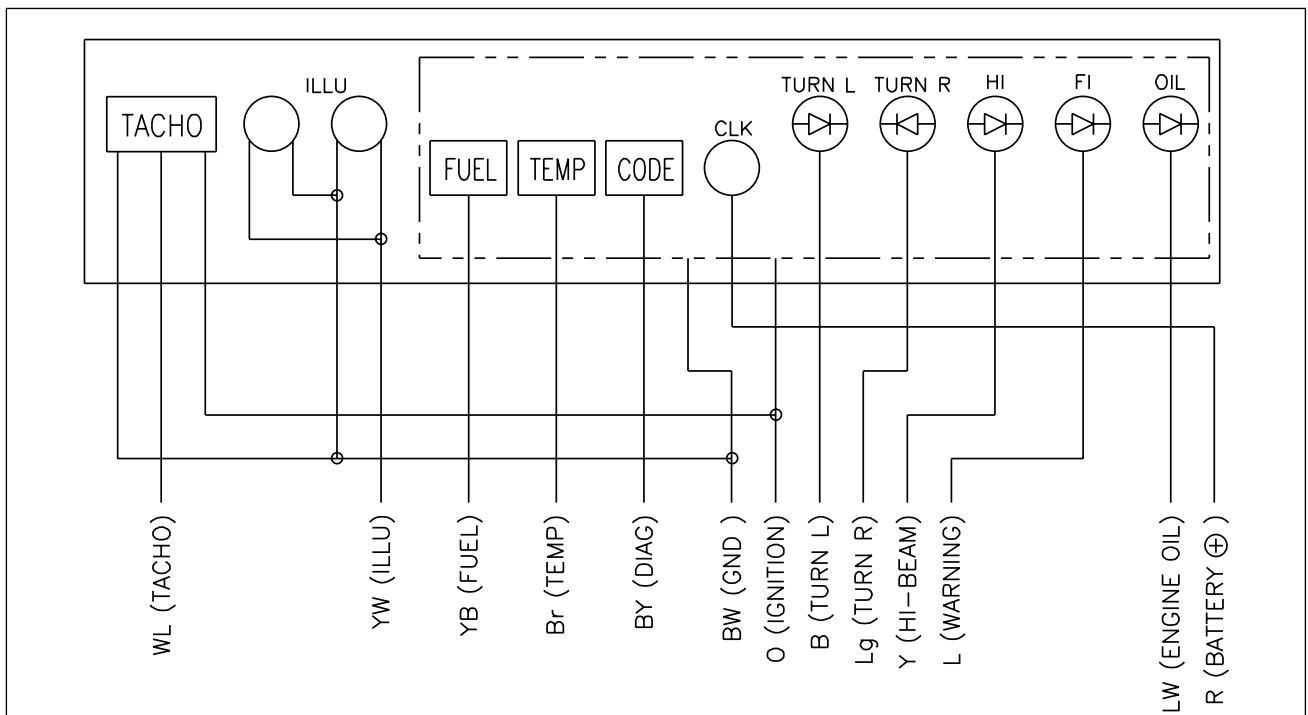
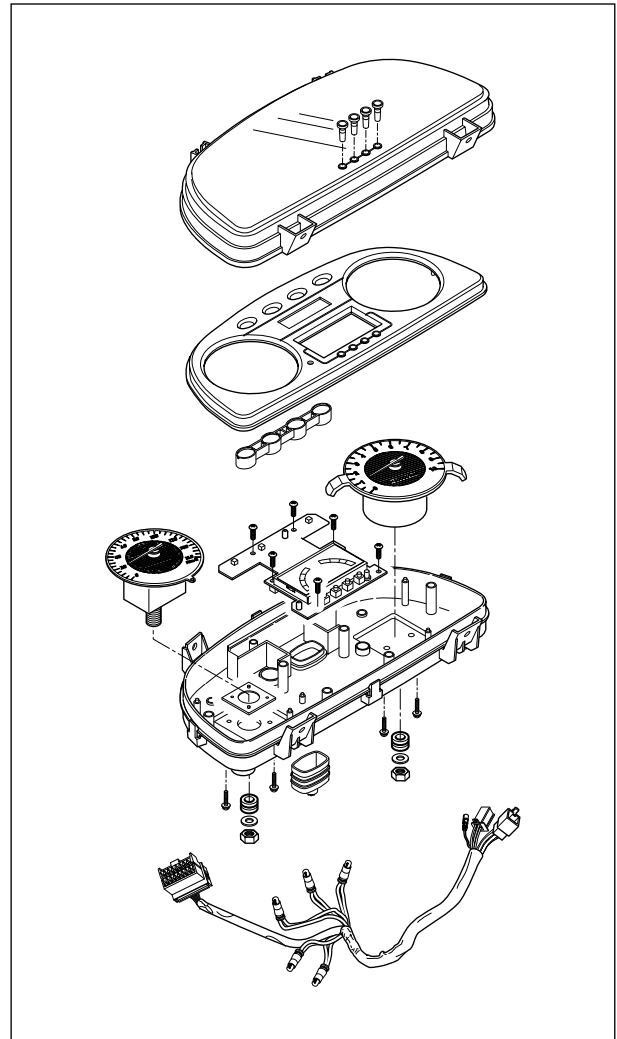

BATTERY

⦿ CAUTION OF BATTERY TREATMENT

The battery needs attention generally as it occurs flammability gas.

If you don't follow the instruction in the below, there may be an explosion and severe accident.

Therefore, pay attention to the following points.

- Positively prohibit battery from contacting to short, spark or firearms.
- The recharge of battery should be done in the wide place where the wind is well ventilated.
Don't recharge it at the sight of windproof.

⦿ CAUTION OF BATTERY ELECTROLYTE TREATMENT

- Pay attention to the battery electrolyte not to stain the chassis or the human body.
- If stains the chassis or the human body, at once wash a vast quantity of water.
When they were stained, clothes will come into being a hole or painting will take off.
Consult a doctor.
- When the battery electrolyte was dropped to the surface of land, wash it with a vast quantity of water.
Neutralize by hydroxide, bicarbonate of soda and so on.

⦿ CAUTION OF MAINTENANCE FREE BATTERY TREATMENT

- Do not remove the aluminum tape to seal the battery electrolyte filler hole until use as battery of complete seal type.
- Do not use it except the battery electrolyte.
- Pouring into the battery electrolyte, necessarily use the electrolyte of the specified capacity.
- Do not open the sealing cap after recharging the battery electrolyte.

▣ FILLING ELECTROLYTE

- ① Put the battery on even land and remove the aluminum tape sealing.
- ② Remove the cap at the electrolyte container.



CAUTION

Do not remove the seal of the electrolyte container, not prick with sharp thing.

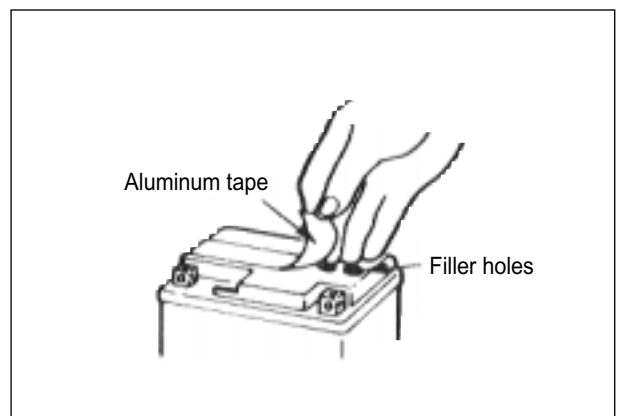
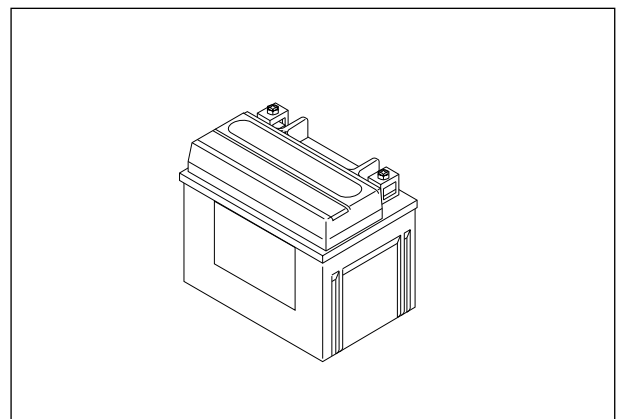

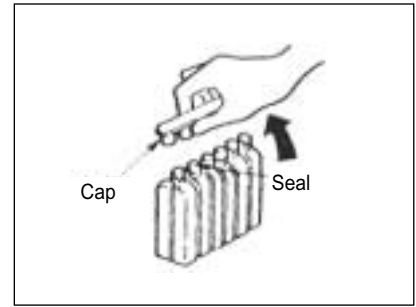
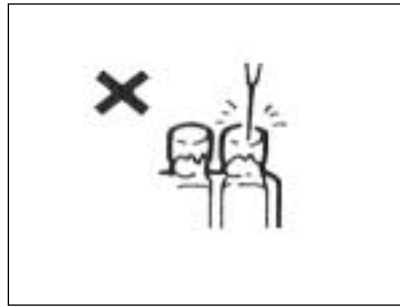
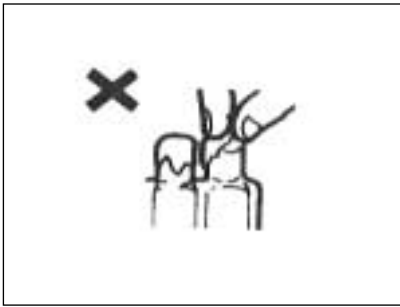

- ③ Pouring of battery electrolyte
 When insert the nozzles of the electrolyte container into the battery's electrolyte filler holes, holding the container firmly so that it does not fall.
 Take precaution not to allow any fluid to spill.

⚠ CAUTION
 The pouring of electrolyte may not be done if the electrolyte container is pushed slopely.

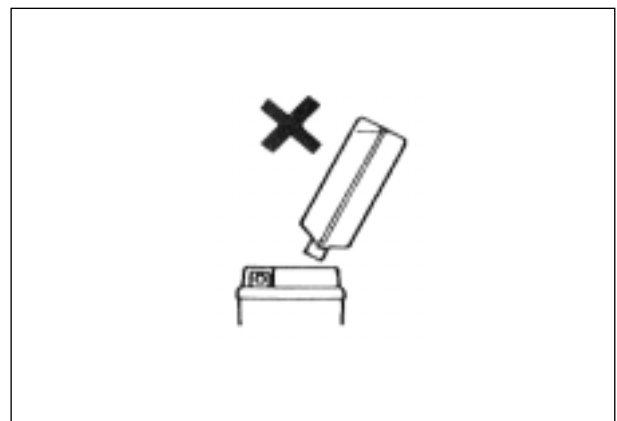
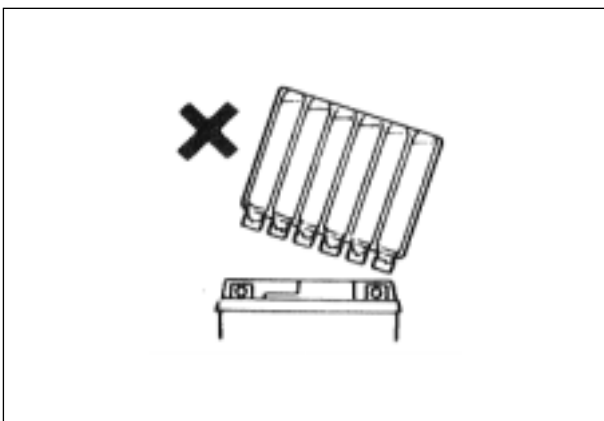
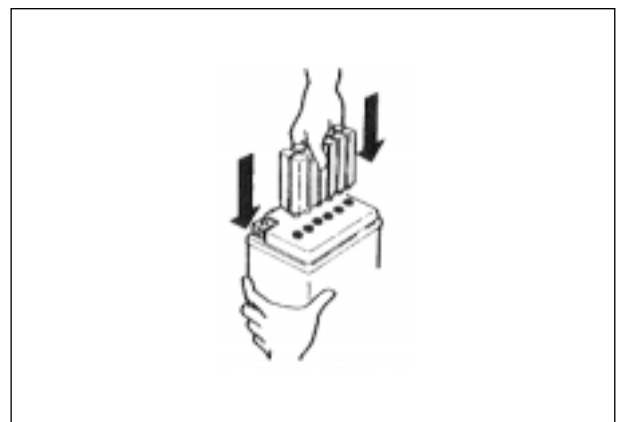

- ④ Confirmation of pour
 Make sure that air bubbles are coming up each electrolyte container, and keep this position for more than about 20 minutes.

⚠ CAUTION
 If no air bubbles are coming up from a filler port, tap the bottom two or three times.

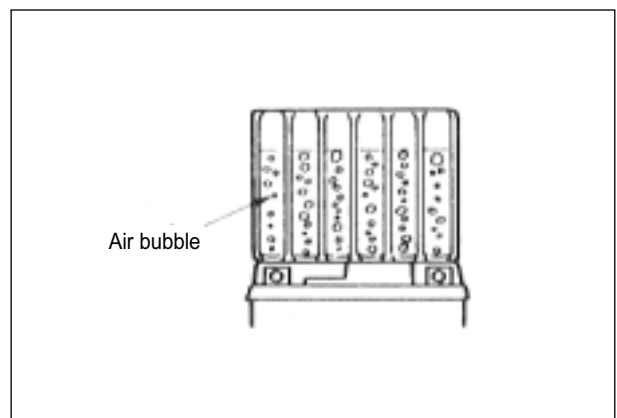

7-17 ELECTRICAL SYSTEM

⑤ Separation of electrolyte container

After confirming that you entered the electrolyte into battery completely, remove the electrolyte containers from the battery.

CAUTION

Draw the empty receptacle out slowly because there may be a chance remaining electrolyte vaporize.

⑥ Insert the caps

Insert the cap into the filler holes, pressing it firmly so that the top of the caps do not protrude above the upper surface of the battery's top cover.

⊙ SERVICING

Visually inspect the surface of the battery container. If any signs of cracking or electrolyte leakage from the sides of the battery have occurred, replace the battery with a new one. If the battery terminals are found to be coated with rust or an acidic white powdery substance, then this can be cleaned away with sandpaper.

⊙ RECHARGING OPERATION

- Using the pocket tester, check the battery voltage. If the voltage reading is less than the 12.0 V (DC), recharge the battery with a battery charger.

How to charge

Standard	0.8 A × 5~10 hours
Fast	4 A × 30 minutes

CAUTION

When recharging the battery, remove the battery from the vehicle.

NOTE

Do not remove the caps on the battery top while recharging.

CAUTION

Be careful not to permit the charging current to exceed 4A at any time.

- After recharging, wait for more than 30 minutes and check the battery voltage with a pocket tester.
- If the battery voltage is less than the 12.5V, recharge the battery again.
- If battery voltage is still less than 12.5V, after recharging, replace the battery with a new one.
- When the vehicle is not used for a long period, check the battery every 1 month to prevent the battery discharge.

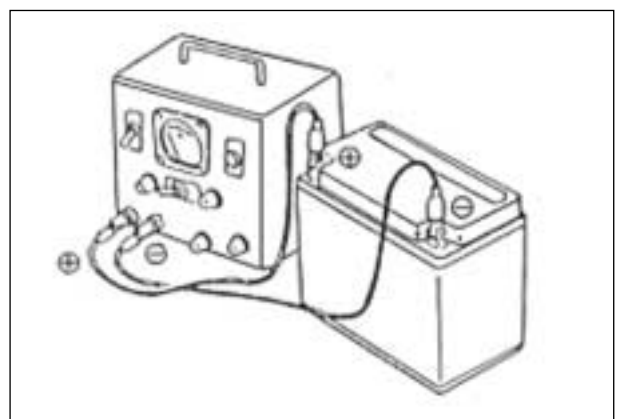
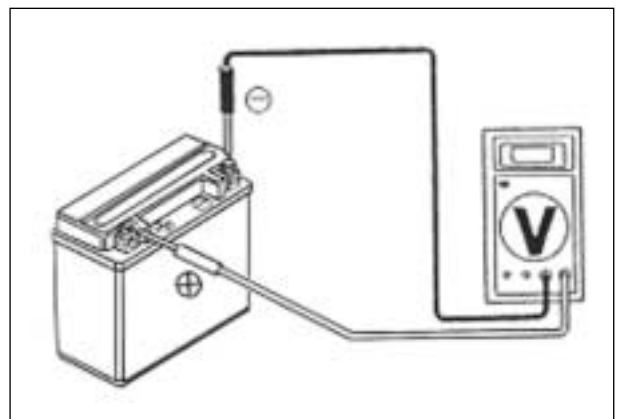
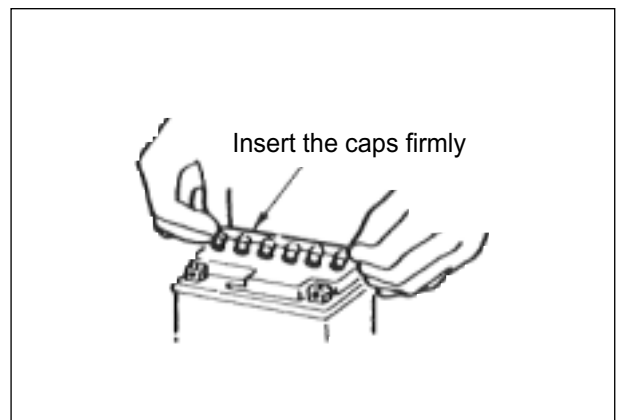

CHASSIS

CONTENTS

EXTERIOR PARTS	8- 1
FRONT WHEEL	8- 9
FRONT BRAKE	8-15
HANDLEBAR	8-23
FRONT FORK	8-25
STEERING	8-29
REAR WHEEL	8-32
REAR BRAKE	8-35
REAR SHOCK ABSORBER	8-37

EXTERIOR PARTS

◎ HANDLE COVER

- Remove the two screws ① of the handle rear cover.

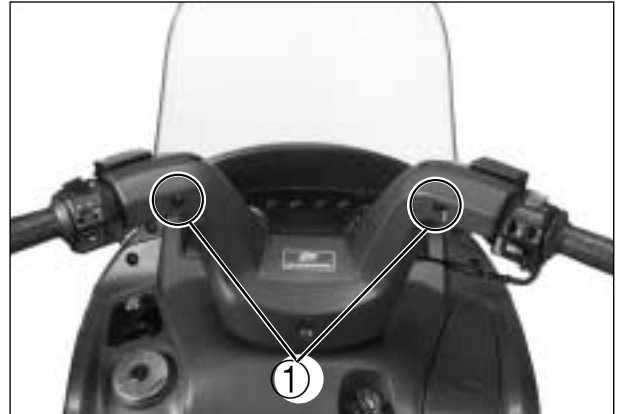

- Remove the three screws ② of the leg shield front upper decoration.
- Remove the leg shield front upper decoration ③.

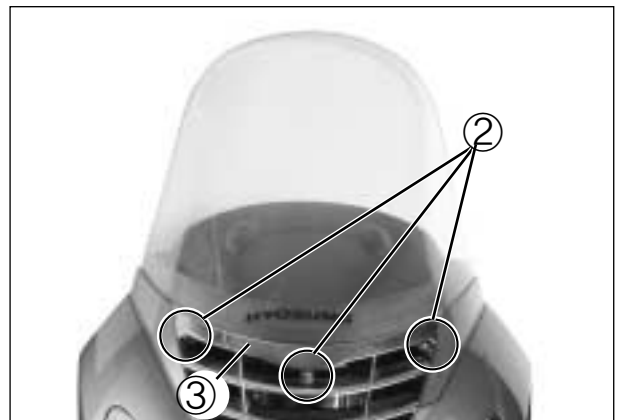

- Remove the screw ④ of the right and left leg shield front decoration ⑤.

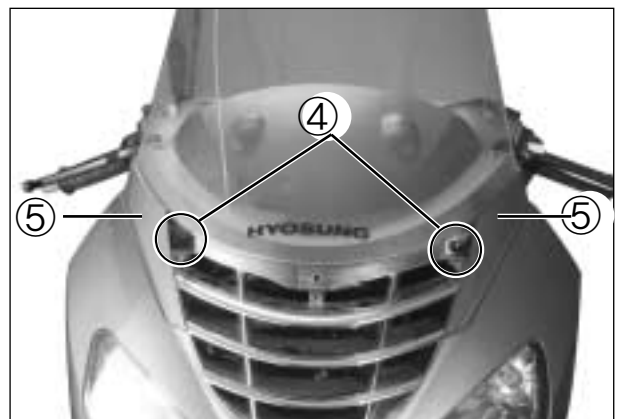

- Remove the screw ⑥ of the speedometer rear cover, right and left.
- Remove the right and left leg shield front decoration ⑤.

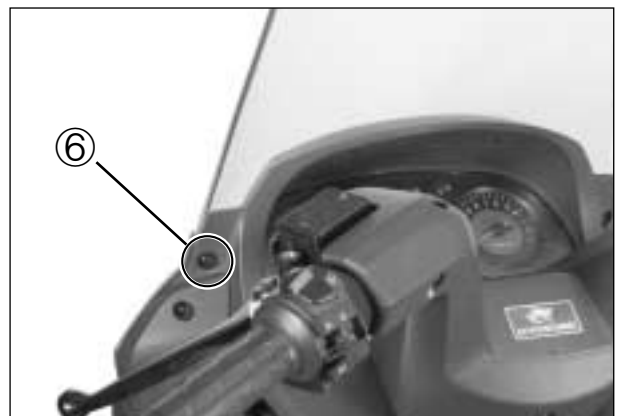

- Remove the three screws ① of the windscreen.
- Remove the windscreen ② .

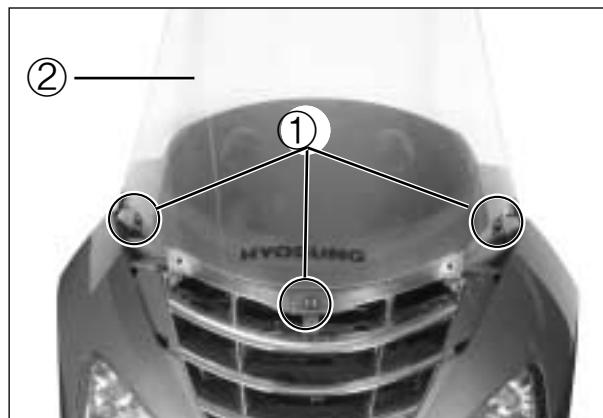

- Remove the two screws ③ of the handle front cover.
- Remove the handle front cover ④ .

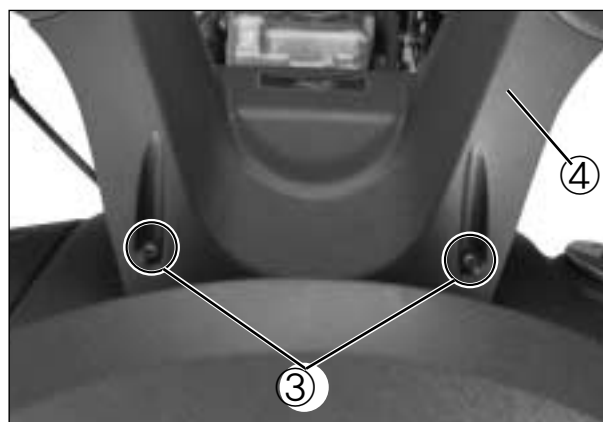

- Remove the two screws ⑤ of the handlebar.

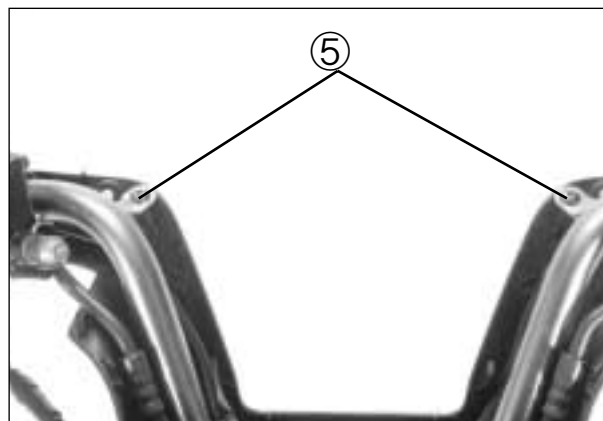

- Remove the handle rear cover center screw ⑥ .
- Remove the handle rear cover ⑦ .

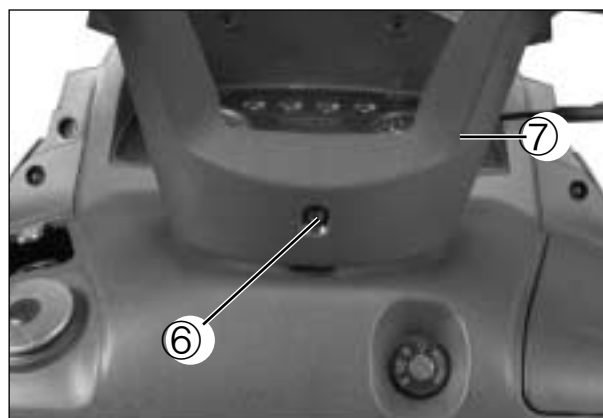

◎ SPEEDOMETER COVER

- Remove the handle cover. (Refer to page 8-1)
- Remove the two screws ① of the speedometer rear cover.
- Remove the speedometer rear cover ②.

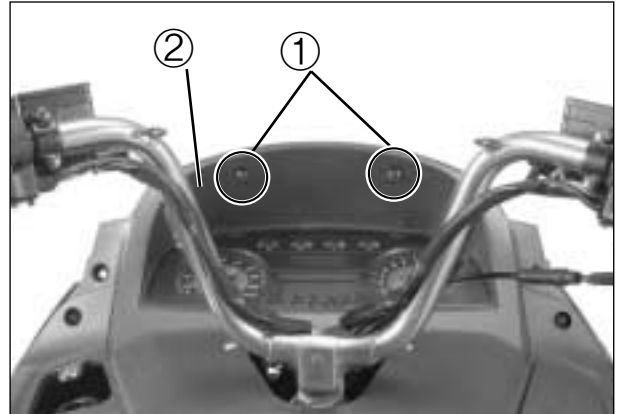

- Remove the two screws ③ of the speedometer front cover.



- Remove the screw ④ of the speedometer front cover, right and left.
- Remove the speedometer front cover ⑤.

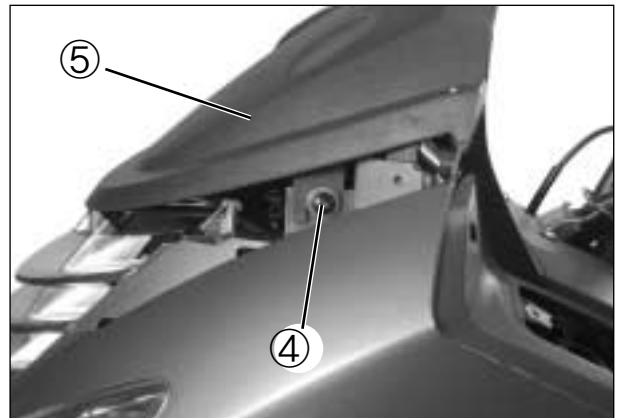

◎ FRONT LEG SHIELD

- Remove the handle cover. (Refer to page 8-1)
- Remove the speedometer cover. (Refer to above)
- Remove the screws ⑥ of the front fender to prevent the front leg shield's damage.
- Remove the front fender ⑦.

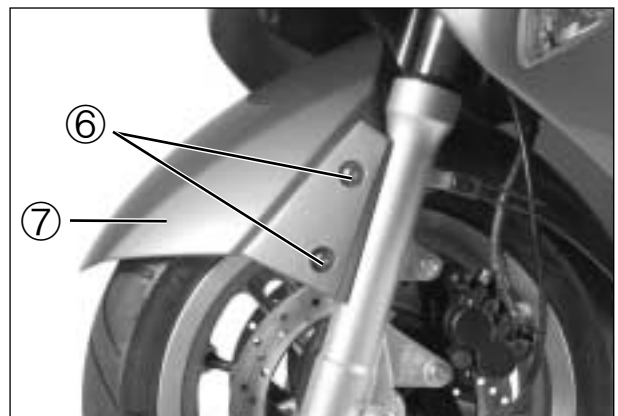

- Remove the two screws ① of the front leg shield.

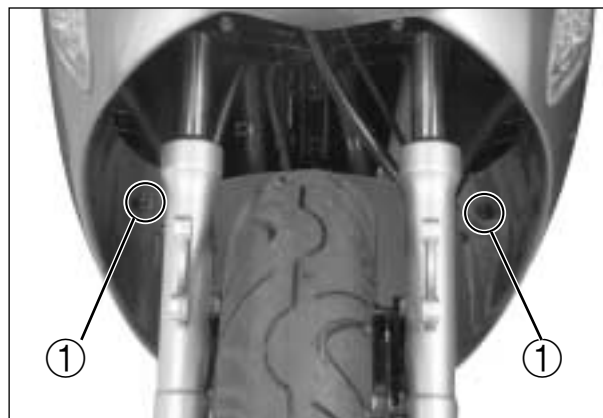

- Remove the four screws ② of the leg shield cover, right and left.

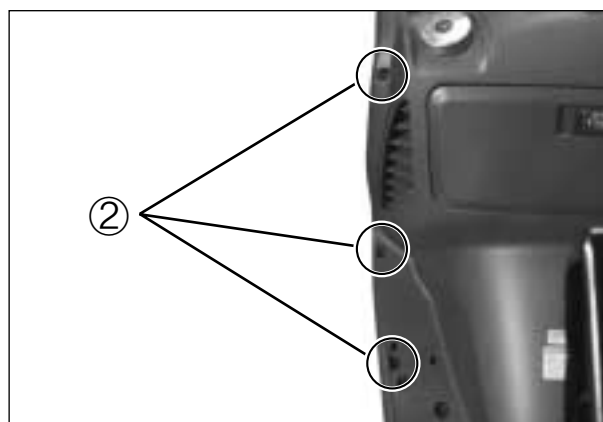
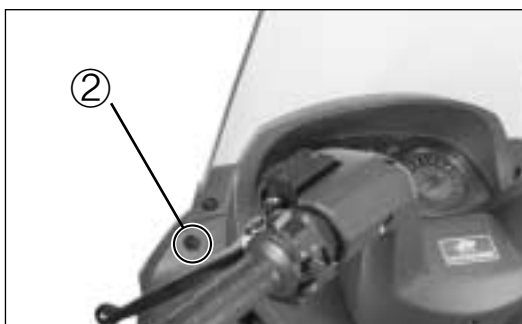

- Disconnect the head lamp coupler ③ and position lamp coupler ④, right and left.
- Remove the front leg shield.

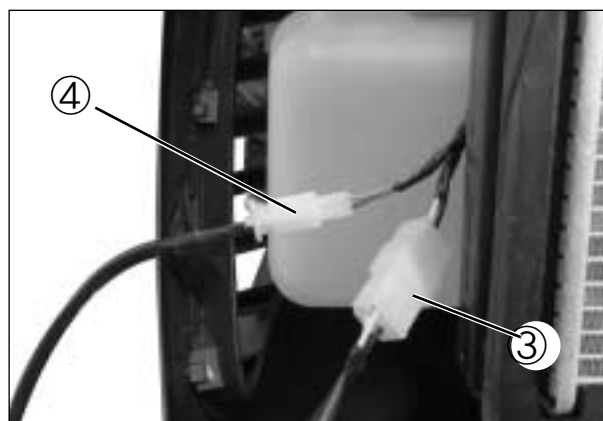

⊙ SPEEDOMETER

- Remove the handle cover. (Refer to page 8-1)
- Remove the speedometer cover. (Refer to page 8-3)
- Remove the front leg shield. (Refer to page 8-3)
- Remove the two screws ⑤.
- Remove the two screws ⑥ of the brace.
- Disconnect the speedometer cable ⑦.

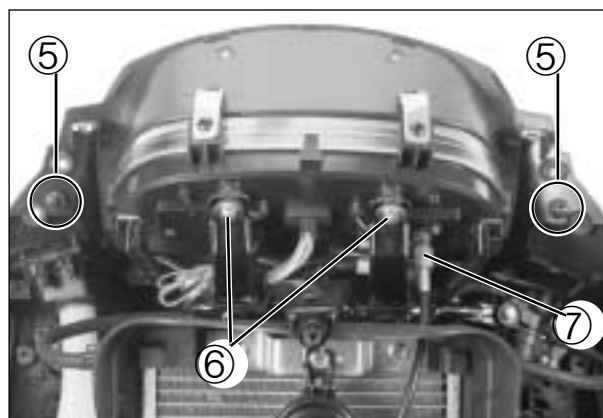

8-5 CHASSIS

- Remove the two screws ① of the leg shield cover.

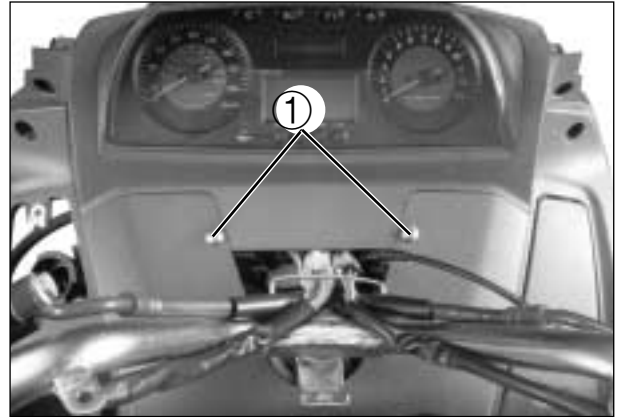

- Disconnect the speedometer couplers ②, ③, ④.
- Remove the speedometer.

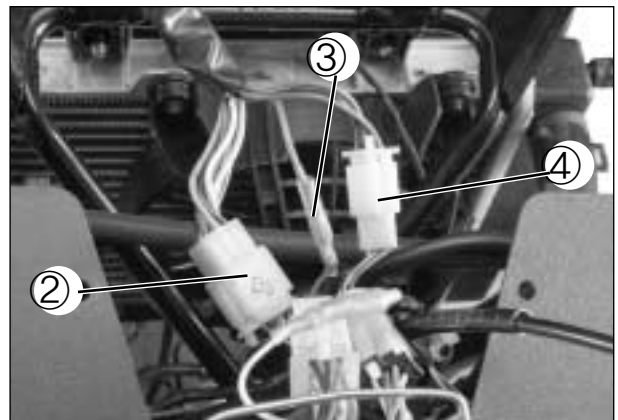

⊙ LEG SHIELD COVER

- Remove the front leg shield. (Refer to page 8-3)
- Remove the speedometer. (Refer to page 8-4)
- Remove the fuel tank cap ⑤, radiator cap cover ⑥, coolant reservoir tank filler cap cover ⑦, coolant reservoir tank filler cap and ignition switch ⑧.

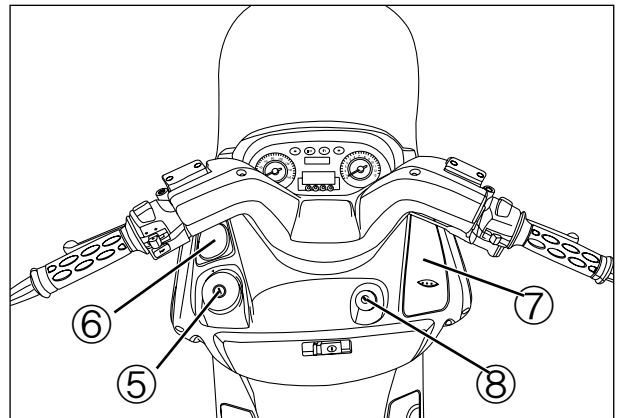

- Remove the fuel tank hose clamp and breather hose clamp.

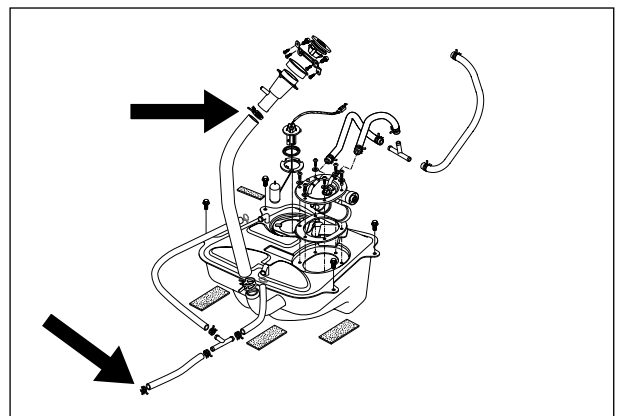

- Remove the output terminal coupler①.

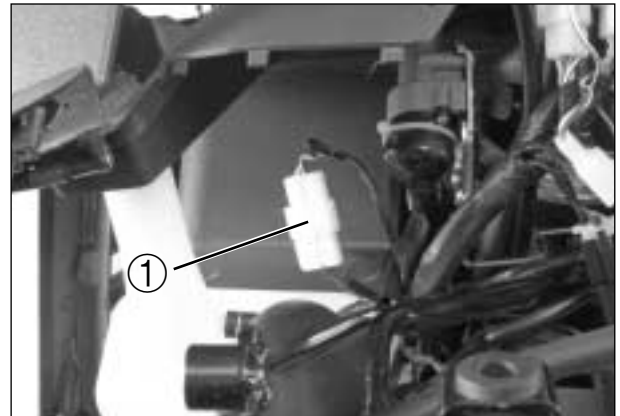

- Remove the leg shield cover screws②,③,④.
- Remove the leg shield cover.



⊙ LOWER LEG FRONT SHIELD

- Remove the leg shield cover. (Refer to page 8-5)
- Remove the lower leg front shield screw⑤.
- Remove the lower leg front shield.

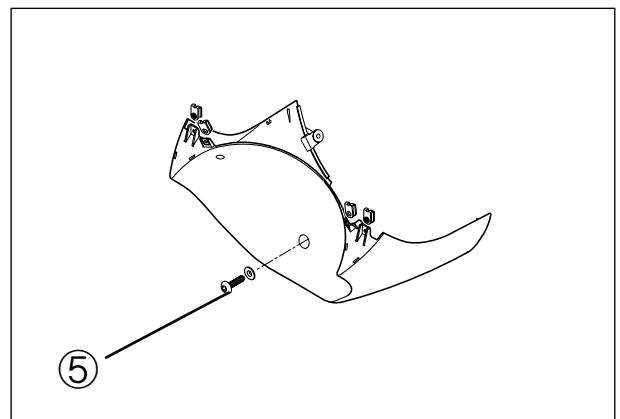

⊙ FUEL TANK LOWER COVER

- Remove the four screws⑥ of the fuel tank lower cover.

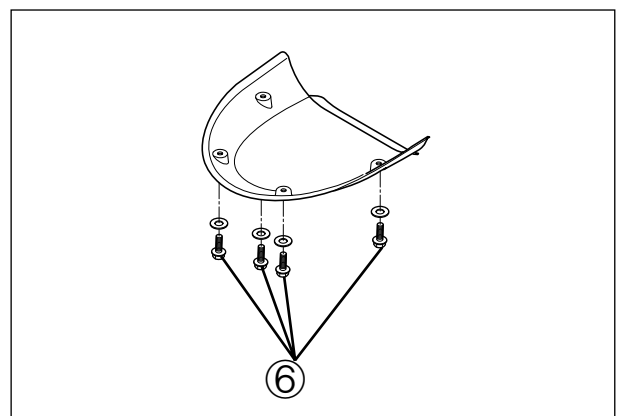

◎ REAR LEG SHIELD

- Remove the rear leg shield bolts①.
- Remove the rear leg shield②.

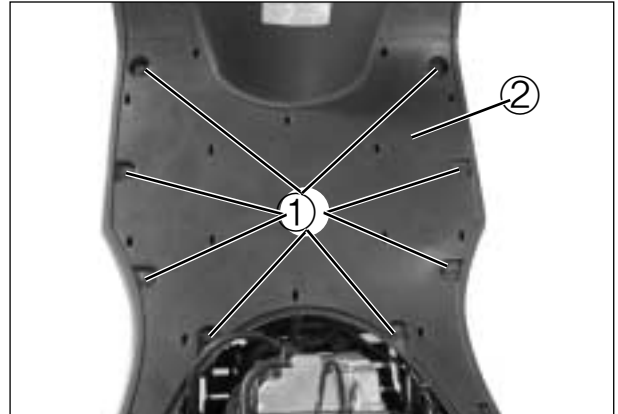

◎ LOWER LEG REAR SHIELD

- Remove the screws ③ of the right and left lower leg rear shield.

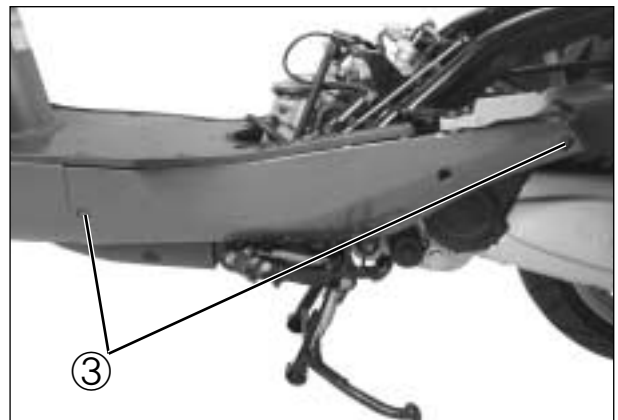

◎ 「SEAT, SIDE COVER & REAR FENDER」 ASSEMBLY

- Position the motorcycle on the center stand.
- Raise the seat.

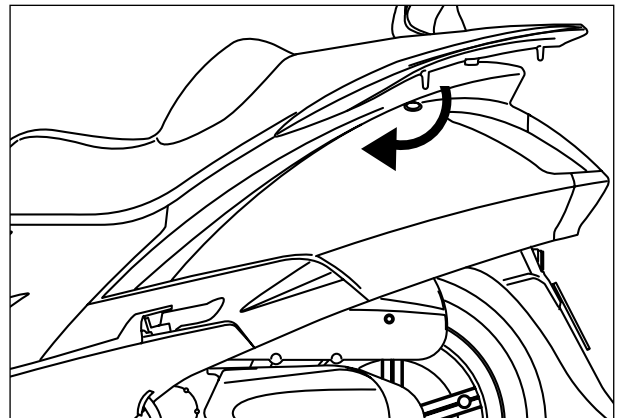

- Remove the two bolts④ in the personal trunk.

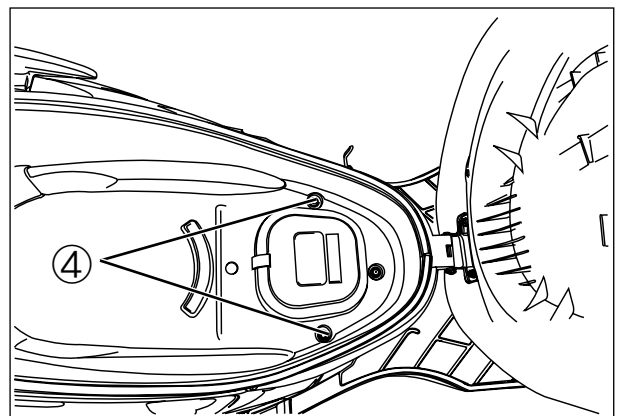

- Remove the two bolts① of the rear carrier.
- Push the side cover for the rear side.

⚠ CAUTION

Proceed with care.
Do not damage the cover, reflector and lamp.
Handle plastic and paint-finished parts with care to avoid scratching or damage.

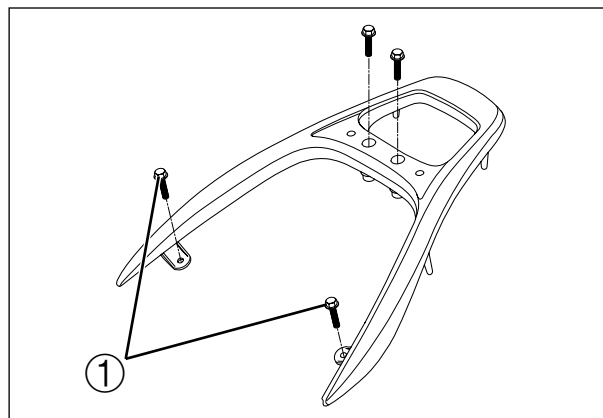

- Disconnect the tail lamp coupler.
- Lift the front end of the 「Seat, side cover & rear fender」 assembly and push it for backward thoroughly.
- Remove the 「Seat, side cover & rear fender」 assembly②.

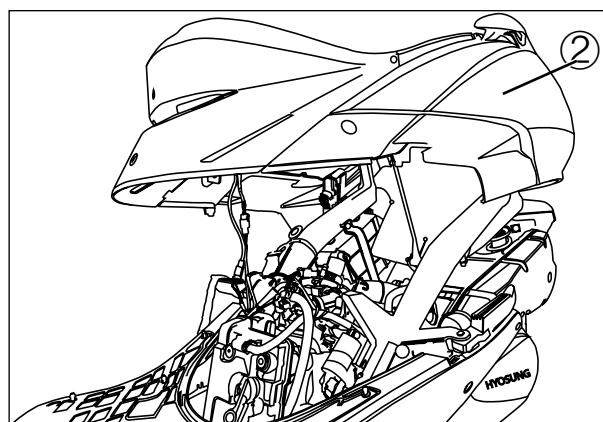

⊙ REAR MUD GUARD

- Remove the eight screws of the rear mud guard ③.



⊙ PASSENGER BACKREST

To remove the passenger backrest :

- Remove the four backrest cover mounting bolt④ .
- Remove the backrest cover⑤ .
- Remove the one backrest mounting bolt⑥ .
- Remove the backrest⑦ .
- Remove the two backrest bracket mounting bolt ⑧ .
- Remove the backrest bracket⑨ .

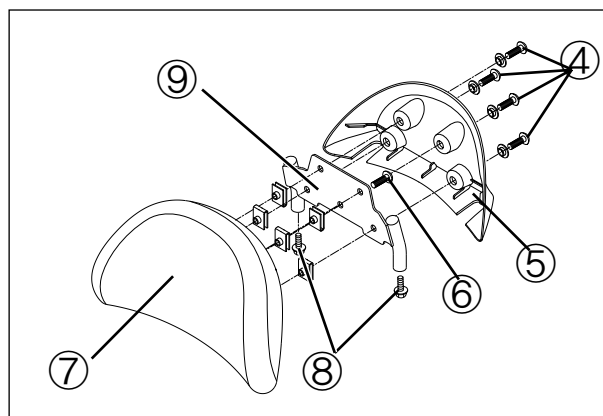

⊙ INSTALLATION

Install the exterior parts in the reverse order of removal.

FRONT WHEEL

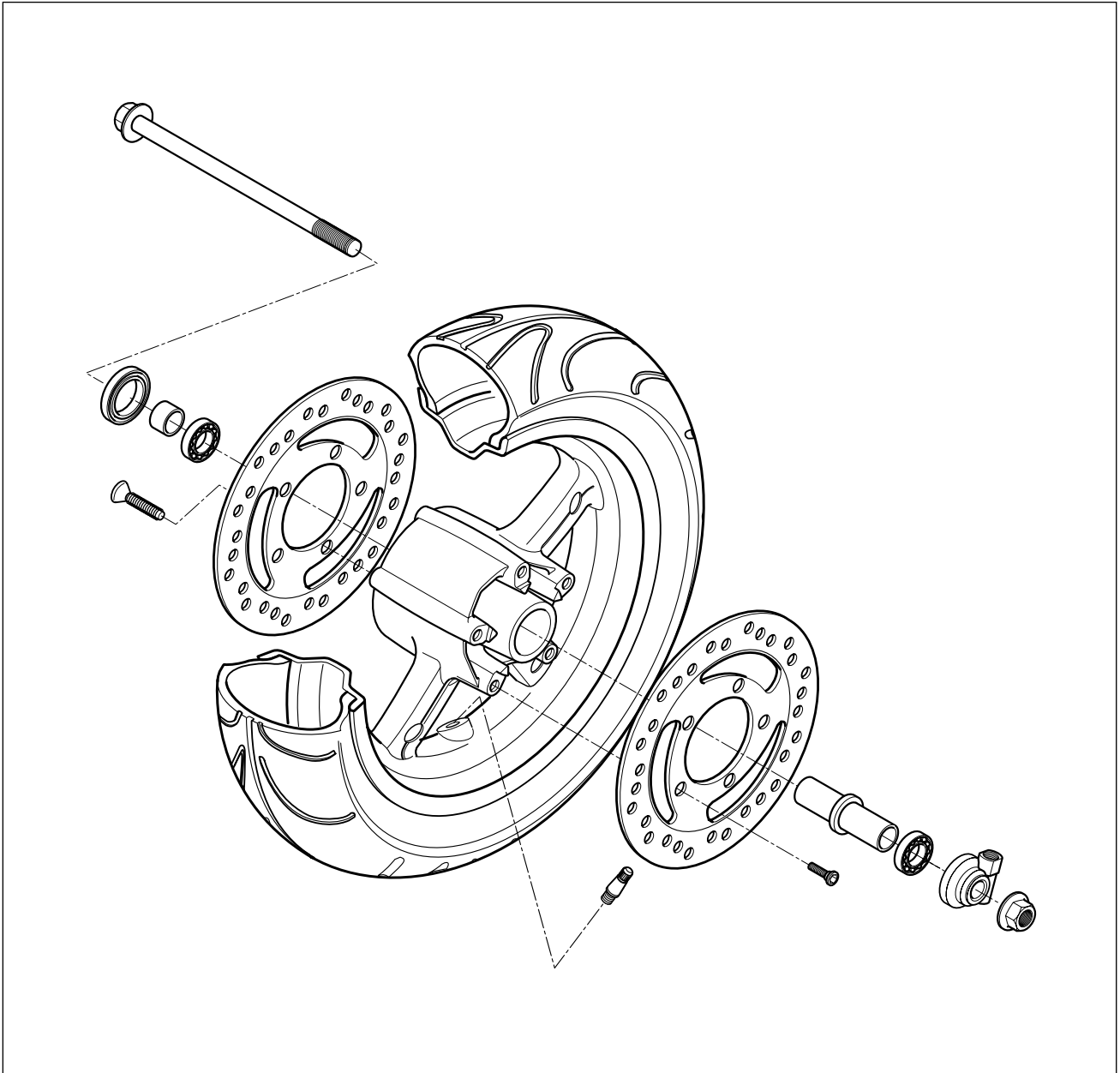

⊙ REMOVAL AND DISASSEMBLY

- Remove the front brake caliper, right and left, by removing the mounting bolts (A).

 **CAUTION**

Do not operate the front brake lever while dismounting the caliper.

- Remove the front axle nut (B).
- Support the motorcycle by jack or wooden block.
- Remove the front wheel and speedometer gear box by removing the front axle shaft.

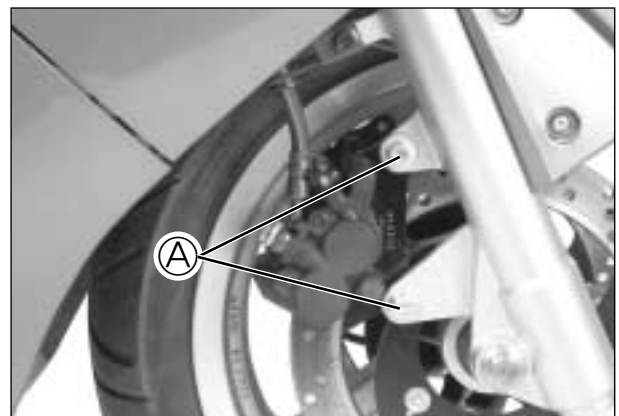

[Right front brake]

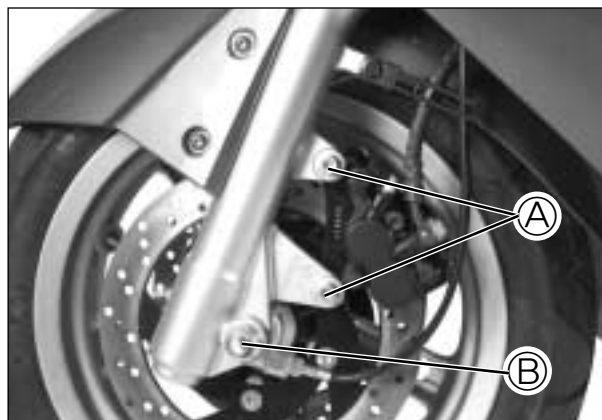

[Left front brake]

- Remove the disk plate, right and left, by removing the bolts①.

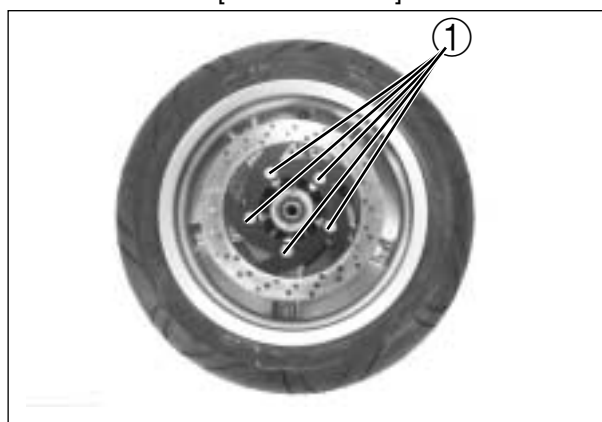

- Remove the spacer②.

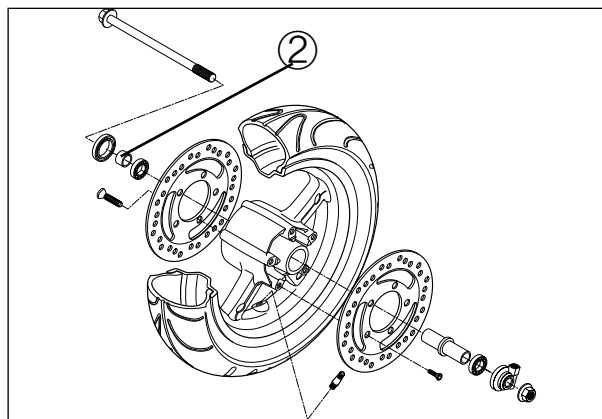

- Remove the oil seal③ with the special tool.

 Oil seal remover : 09913-50121

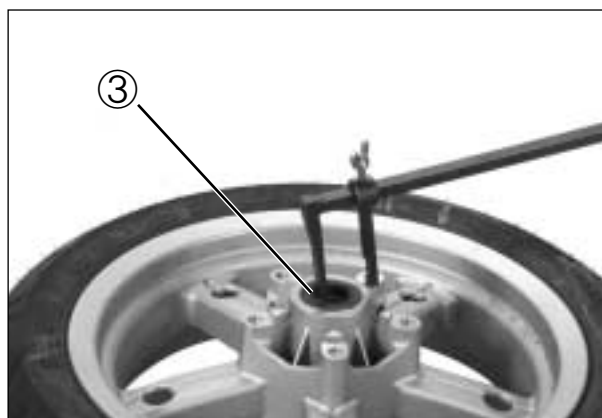

8-11 CHASSIS

Drive out the both bearing with the special tool in the following procedures.

- Insert the adapter into the bearing.
- After inserting the wedge bar from the opposite side, lock the wedge bar in the slit of the adapter.
- Drive out the bearing by knocking the wedge bar.

 **Wheel bearing remover : 09941-50111**

CAUTION

The removed dust seal and bearing should be replaced with new ones.

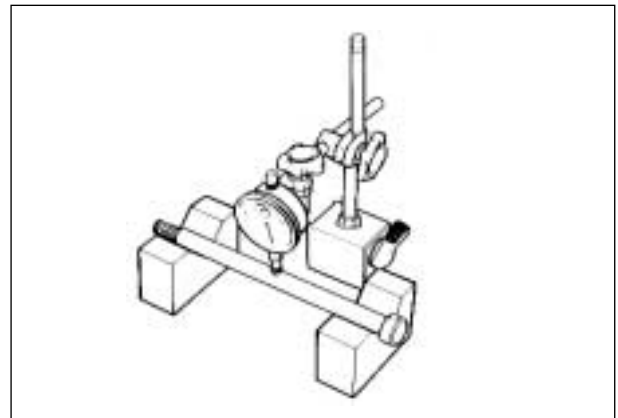
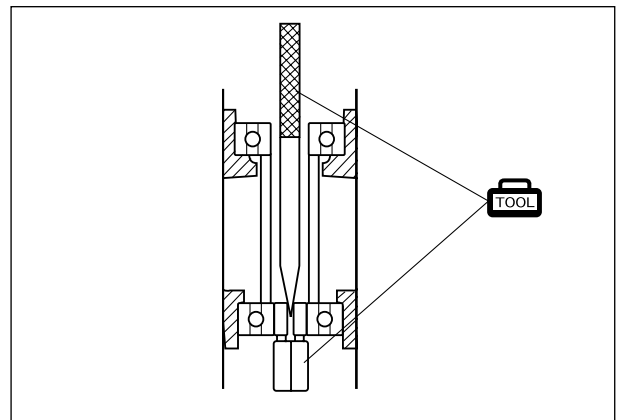
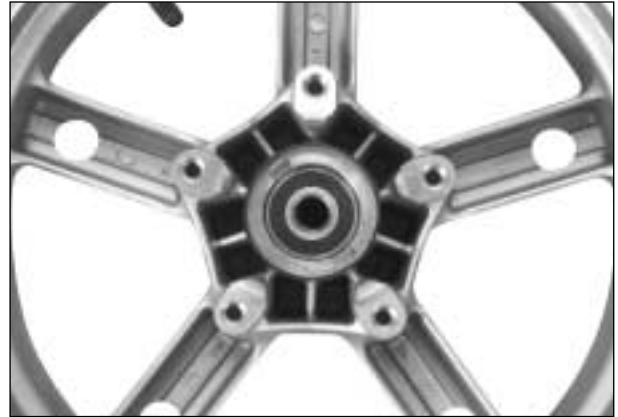

⊙ INSPECTION

▣ FRONT AXLE

Measure the front axle runout using the dial gauge. If the runout exceeds the limit, replace the front axle.

Axle shaft runout	Service limit
	0.2 mm (0.008 in)

 **Dial gauge : 09900-20606**

Magnetic stand : 09900-20701

V-block : 09900-21304

▣ WHEEL RIM

Make sure that the wheel rim runout does not exceed the service limit when checked as shown.

An excessive runout is usually due to worn or loose wheel bearings and can be reduced by replacing the bearings. If bearing replacement fails to reduce the runout, replace the wheel.

Wheel rim runout (Axle)	Service limit
	0.1 mm (0.004 in)

Wheel rim runout (Radial)	Service limit
	0.5 mm (0.020 in)

 **Dial gauge : 09900-20606**

Magnetic stand : 09900-20701

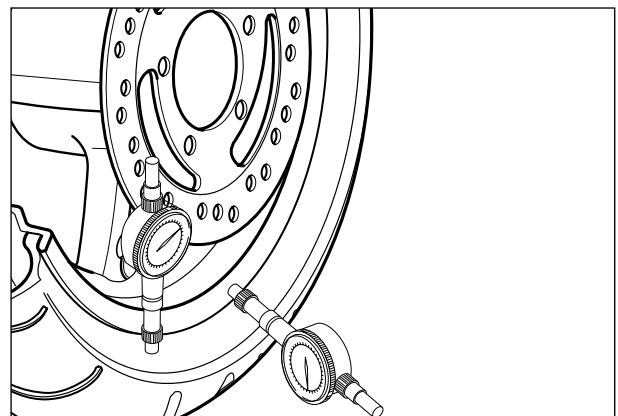

▣ TIRE

☞ For inspection of the tire : Refer to page 2-23

Check the tire pressure, and examine the value for evidence of air leakage.

COLD INFLATION TIRE PRESSURE	SOLD RIDING			DUAL RIDING		
	kPa	kgf/cm ²	psi	kPa	kgf/cm ²	psi
Front	172	1.75	25.0	172	1.75	25.0
Rear	197	2.00	29.0	246	2.50	36.0

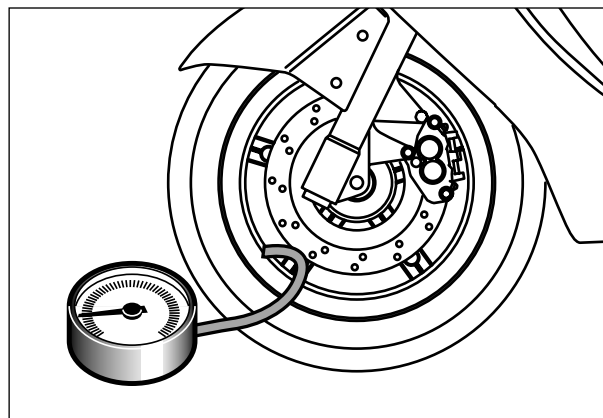

▣ WHEEL BEARING

Inspect the play of the wheel bearings by finger while they are in the wheel. Rotate the inner race by finger to inspect abnormal noise and smooth rotation.

Replace the bearing in the following procedure if there is anything unusual.

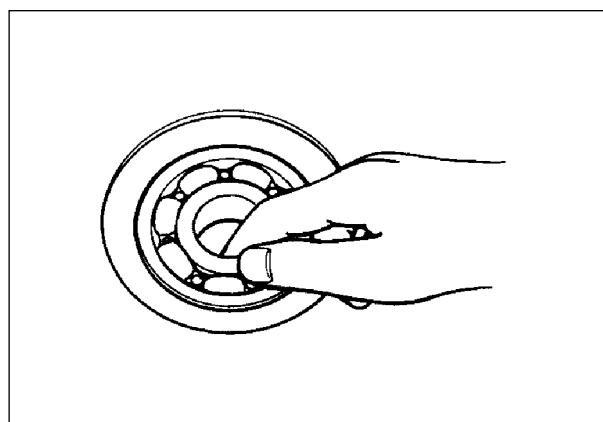

◎ REASSEMBLY AND REMOUNTING

Reassemble and remount the front wheel in the reverse order disassembly and removal, and also carry out the following steps.

▣ WHEEL BEARING

- Apply **SUPER GREASE "A"** to the bearings before installing.



- Install the wheel bearings.

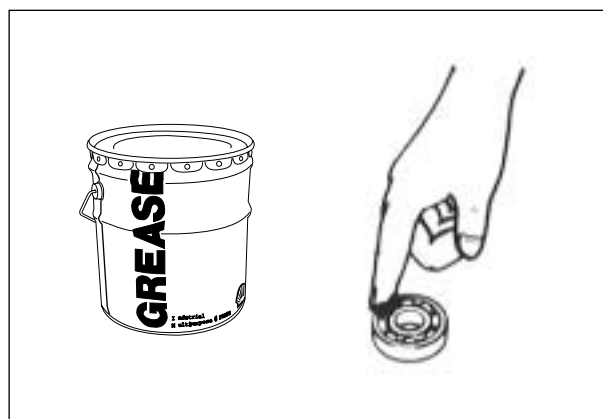

⚠ CAUTION

First install the wheel bearing for left side.

▣ OIL SEAL

- Install the oil seal ① with the special tool.

🔧 TOOL Bearing installer : 09913-76010

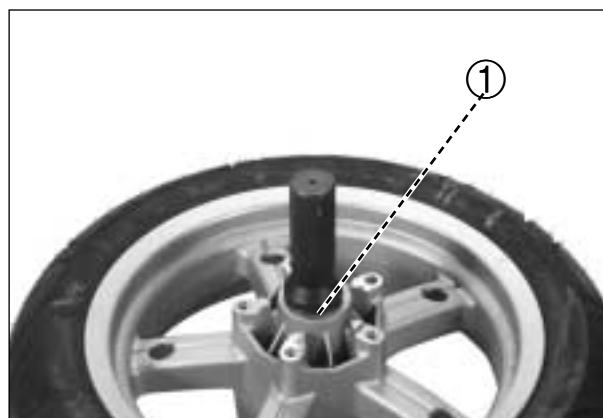

- Install the spacer ①.

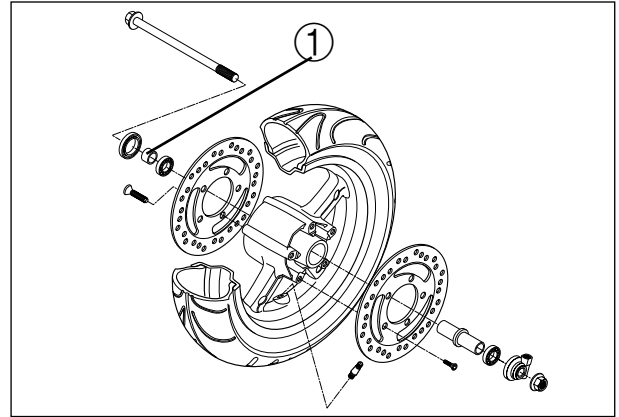

▣ DISK PLATE

- Install the disk plate and tighten them to the specified torque.
- Apply **THREAD LOCK “1324”** to the front brake disk bolt, right and left.

🔧 Front brake disk bolt

: 18 ~ 28 N · m (1.8 ~ 2.8 kgf · m)

🔧 Thread Lock “1324”



▣ SPEEDOMETER GEAR BOX

- When installing the speedometer gear box, align the two drive pawls (A) with the two recesses (B) of the wheel hub.

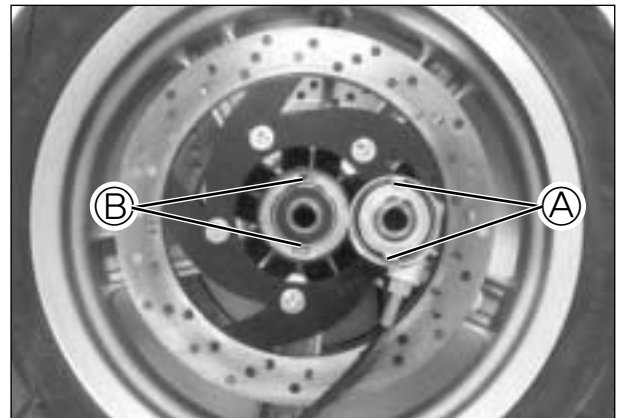

⚠ CAUTION

After touching the speedometer gear box stopper (C) to the shock absorber stopper (D), tighten the axle shaft.

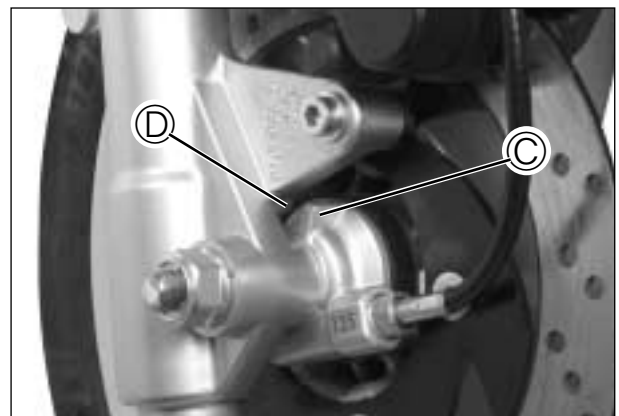

▣ FRONT WHEEL

- Tighten the front axle nut to the specified torque.

🔩 Front axle nut

: 50 ~ 70 N · m (5.0 ~ 7.0 kgf · m)

- Tighten the front brake caliper mounting bolts, right and left, to the specified torque.

🔩 Front brake caliper mounting bolt

: 18 ~ 28 N · m (1.8 ~ 2.8 kgf · m)



[Left front brake]



[Right front brake]

FRONT BRAKE

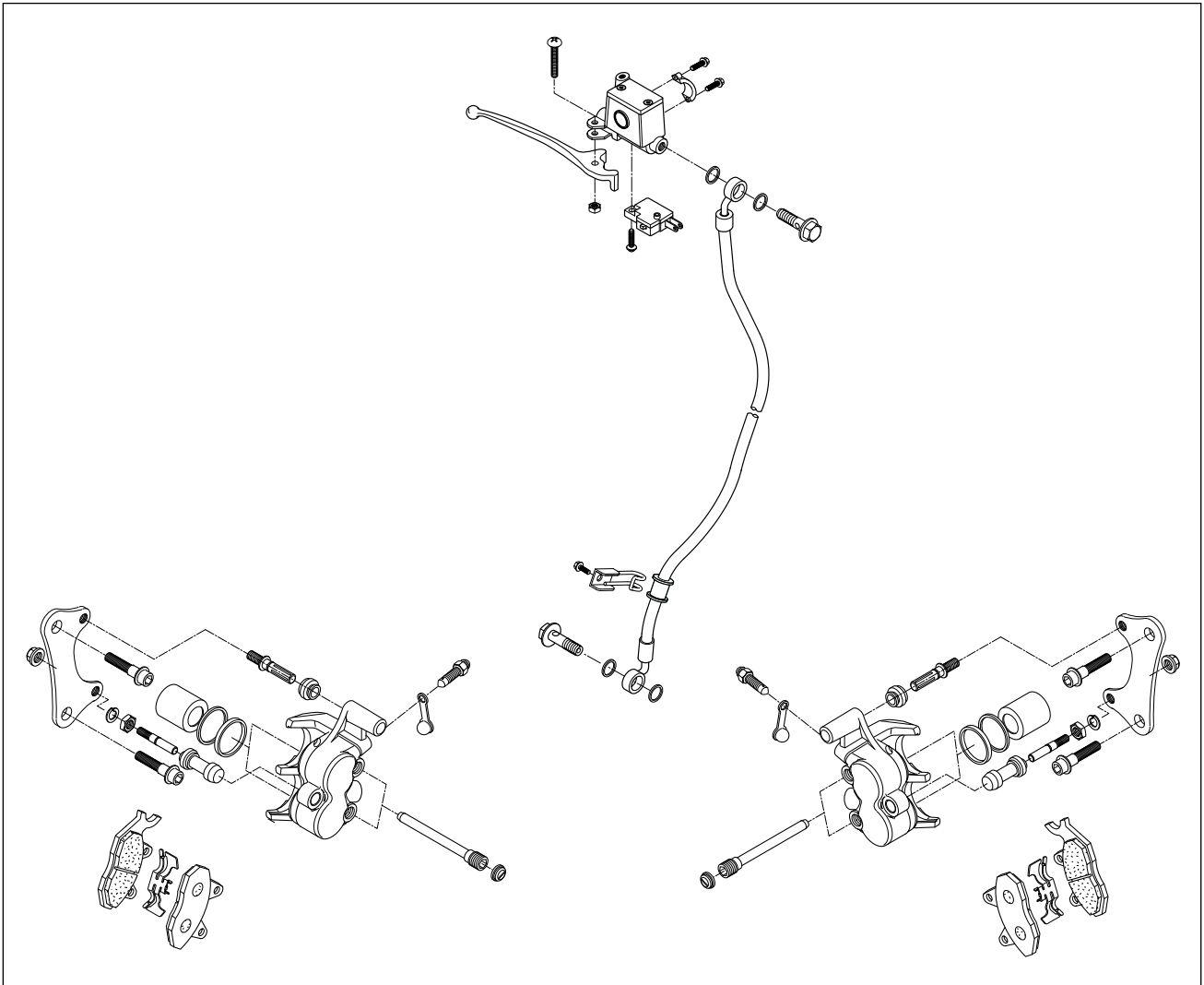

WARNING

- ❖ This brake system is filled with an ethylene glycol-based DOT4 brake fluid. Do not use or mix different types of fluid, such as silicone-based or petroleum-based brake fluids.
- ❖ Do not use any brake fluid taken from old, used or unsealed containers. Never reuse brake fluid left over from the last servicing or stored for a long periods.
- ❖ When storing brake fluid, seal the container completely and keep away from children.
- ❖ When replenishing brake fluid, take care not to get dust into the fluid.
- ❖ When washing brake components, use new brake fluid. Never use cleaning solvent.
- ❖ A contaminated brake disk or brake pad reduces braking performance. Discard contaminated pads and clean the brake disk with high quality brake cleaner or a neutral detergent.

CAUTION

Handle brake fluid with care : the fluid reacts chemically with paint, plastics, rubber materials etc. and will damage them severely.

⊙ BRAKE FLUID REPLACEMENT

- For replacing procedure of brake fluid : Refer to page 2-19

⊙ BRAKE PAD REPLACEMENT

- For replacing procedure of brake pad : Refer to page 2-19

⊙ CALIPER DISASSEMBLY

- Drain brake fluid. (Refer to page 2-19)

⚠ CAUTION

To prevent brake fluid from splashing on the parts nearby, cover the parts with cloth.

- Remove the right and left front brake union bolt ① and caliper mounting bolts ② .
- Remove the brake pad. (Refer to page 2-19)

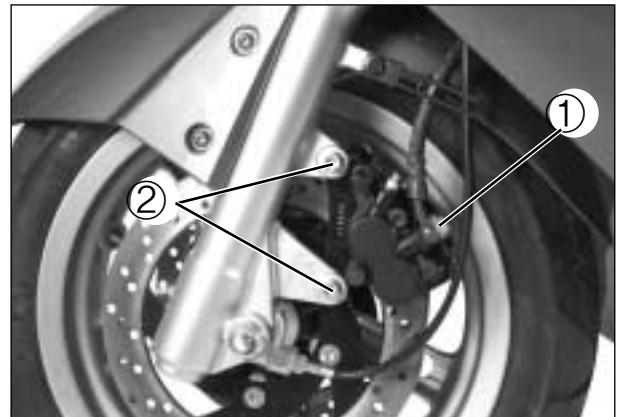

[Left front brake]

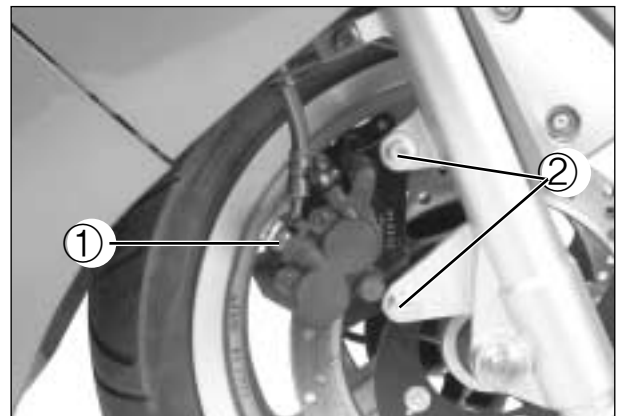

[Right front brake]

- Remove the brake pad mounting bolt's E-ring ③ .

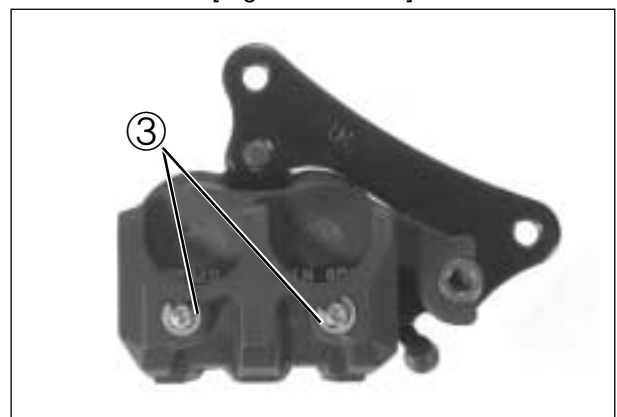

8-17 CHASSIS

- Remove the brake pad mounting cap bolt①.

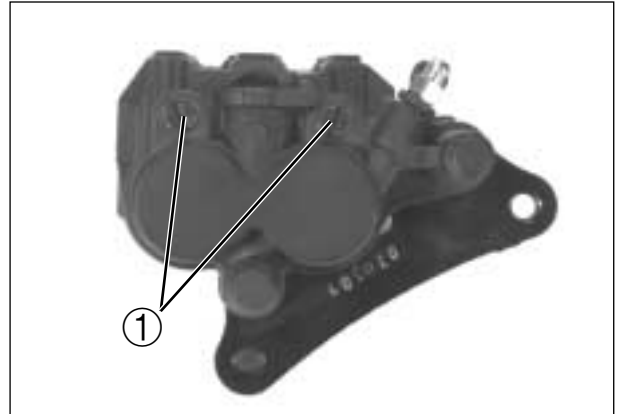

- Remove the brake pad mounting bolt②.

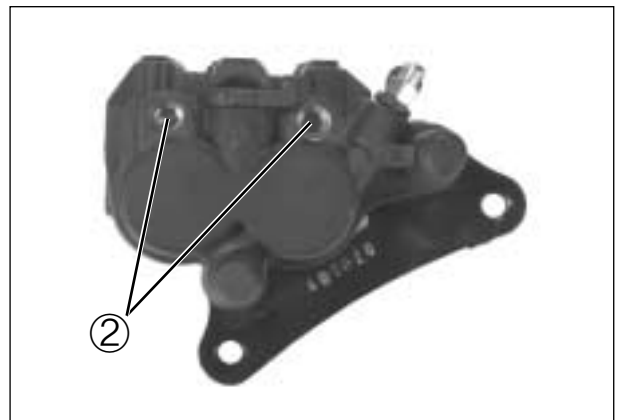

- Remove the brake caliper holder③.

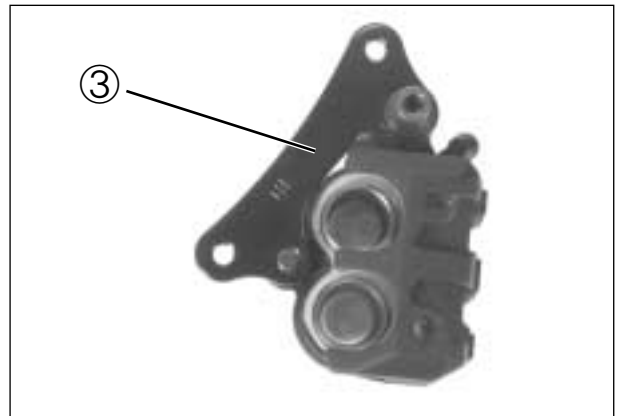

- Using an air gun, push out the caliper piston.

WARNING

- ❖ Place a rag over the piston to prevent it from popping out and flying and keeping hand off the piston.
- ❖ Be careful of brake fluid which can possibly splash.
- ❖ Do not use high pressure air but increase the pressure gradually.



- Remove the dust seal① and piston seal②.

NOTE

- ❖ *Care not to cause scratch on the cylinder bore.*
- ❖ *Do not reuse the piston seal and dust seal that have been removed.*

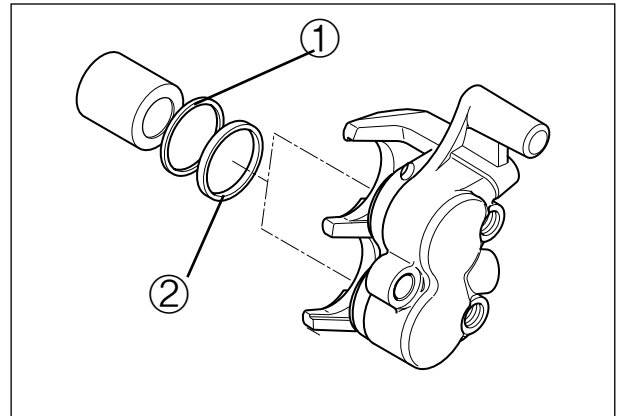

⊙ CALIPER INSPECTION

Inspect the caliper cylinder wall and piston surface for scratch, corrosion or other damages. If any abnormal condition is noted, replace the caliper.



⊙ CALIPER REASSEMBLY

Reassemble the caliper in the reverse order of disassembly procedures and observe the following points.

NOTE

- ❖ *Wash the caliper components with fresh brake fluid before reassembly. Do not wipe off brake fluid after washing the components.*
- ❖ *Replace the piston seal and dust seal into new ones with brake fluid applied.*



**Brake fluid specification and classification
: DOT 4**

- Install the brake pad spring.

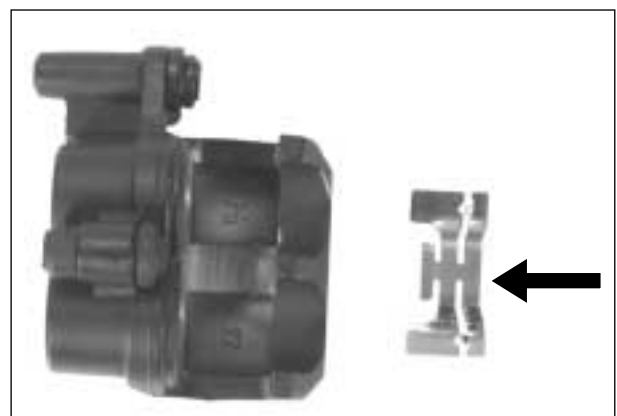
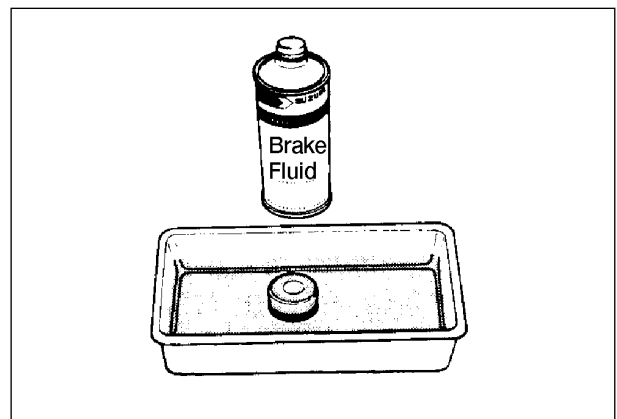

8-19 CHASSIS

- Apply **SILICONE GREASE** to the brake caliper holder.

SILICONE GREASE

- Install the brake pads. (Refer to page 2-19)

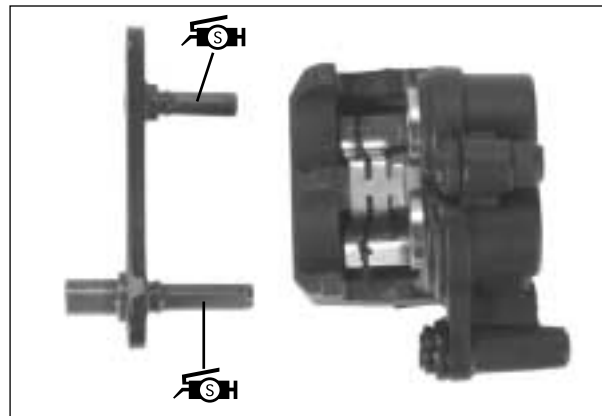

- Tighten the caliper mounting bolts①.
- With the hose end seated to the stopper, tighten the right and left front brake hose union bolt②.

 **Front brake caliper mounting bolts**
: 18 ~ 28 N · m (1.8 ~ 2.8 kgf · m)

Front brake hose union bolts
: 20 ~ 25 N · m (2.0 ~ 2.5 kgf · m)

- Fill the system with brake fluid and bleed air. (Refer to page 2-20)
- Inspection after reassembly : Refer to page 2-18

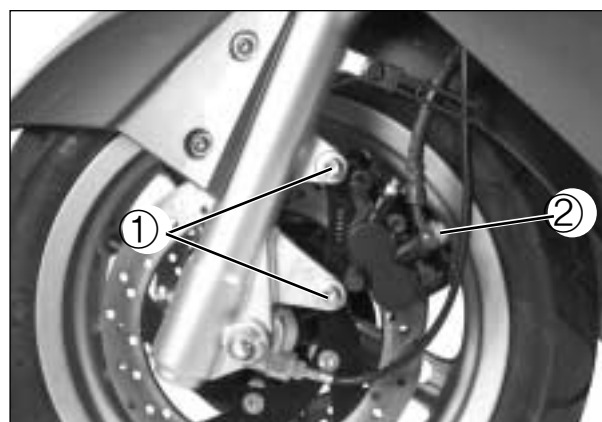

[Left front brake]

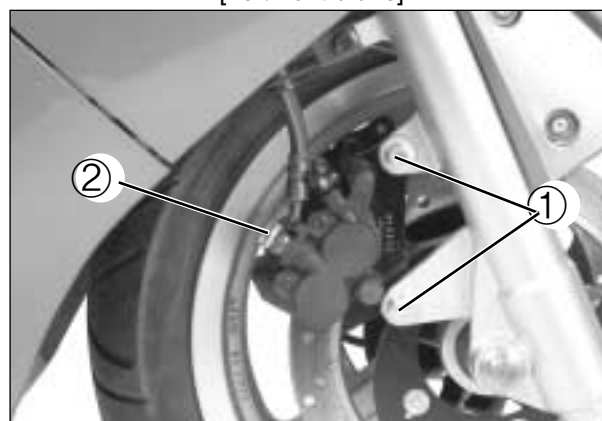

[Right front brake]

⊙ BRAKE DISK INSPECTION

Check the brake disk for damage or cracks. Measure the thickness using the micrometer.
Replace the brake disk if the thickness is less than the service limit or if damage is found.

Brake disk thickness	Service limit
	3.0 mm (0.12 in)

 **Micrometer (0~25 mm) : 09900-20201**

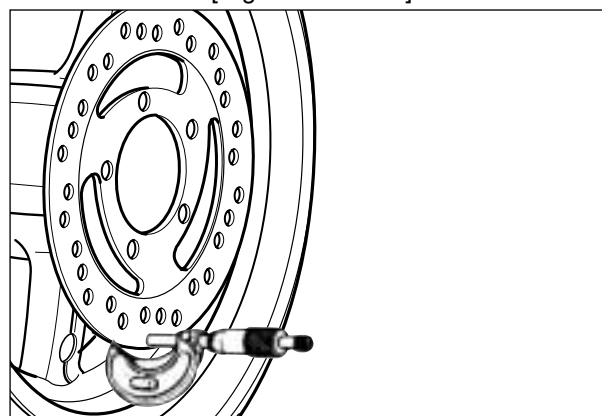

Measure the runout using the dial gauge.
Replace the brake disk if the runout exceeds the service limit.

Brake disk runout	Service limit
	0.08 mm (0.003 in)

 **Dial gauge : 09900-20606**
Magnetic stand : 09900-20701

- If measurement exceeds the service limit, replace the brake disk. (Refer to page 8-10)

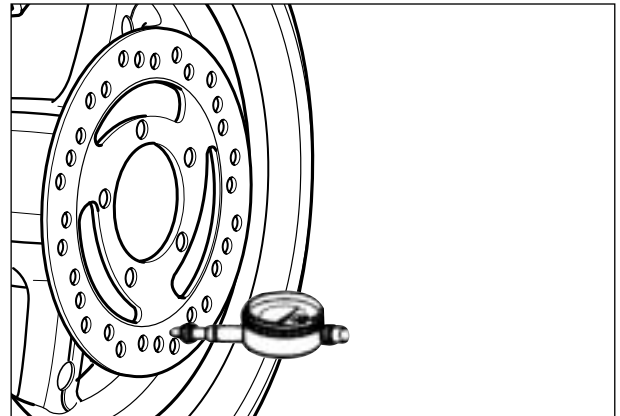

⊙ MASTER CYLINDER DISASSEMBLY

- Remove the handle cover. (Refer to page 8-1)
- Drain brake fluid the master cylinder.
- Disconnect the brake lamp switch lead wire coupler.
- Remove the union bolt ①.

CAUTION

Place a rag under the union bolt so that brake fluid can not contact the parts.

- Remove the two clamp bolts and take off the master cylinder.

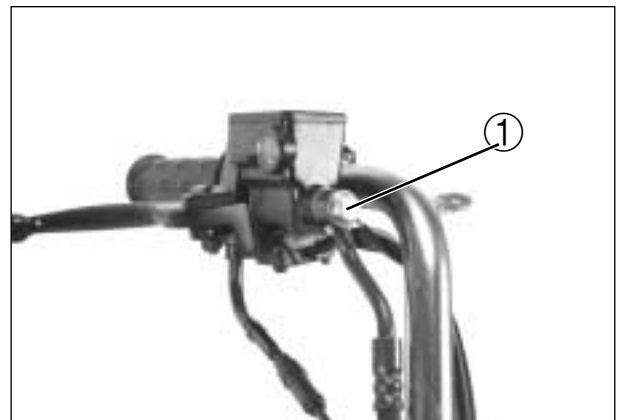

- Remove the two fitting screws and separate the cap and diaphragm.



- Detach the dust seal boot ① and remove the circlip.
- Pull out the piston/cup set ② and spring ③ .

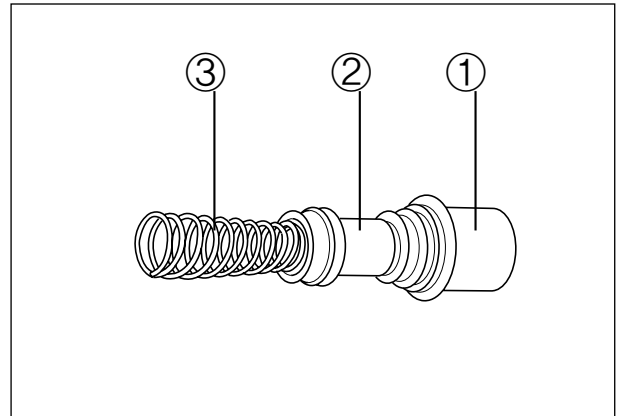

⊙ MASTER CYLINDER INSPECTION

Inspect the master cylinder bore for any scratches or other damage.

Inspect the piston surface for any scratches or other damage.

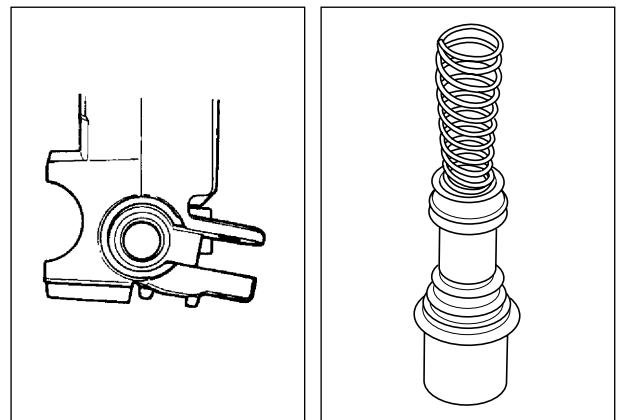

⊙ MASTER CYLINDER REASSEMBLY

Reassemble the master cylinder in the reverse order of disassembly.

Pay attention to the following points :

⚠ CAUTION

- ❖ Wash the master cylinder components with new brake fluid before reassembly.
- ❖ When washing the components, use the specified brake fluid. Never use different types of fluid or cleaning solvents such as gasoline, kerosine, etc.

BF Brake fluid specification and classification : DOT 4

NOTE

When installing the circlip, make sure that the sharp edge of the circlip faces outside.

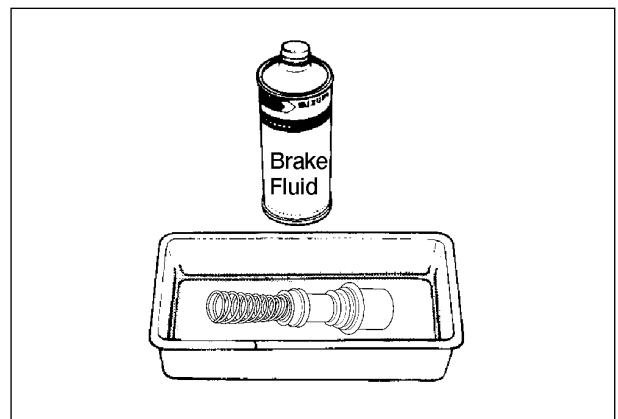

- When remounting the master cylinder to the handlebars, first tighten the clamp bolts for upside as shown.

⚠ WARNING

Bleed air from the brake fluid circuit after assembling master cylinder. (Refer to page 2-20)

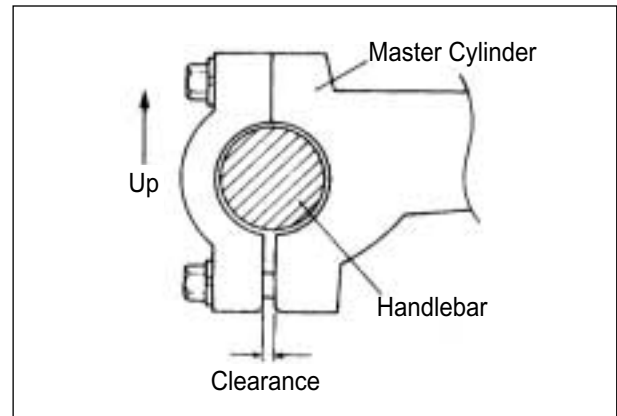

HANDLEBAR

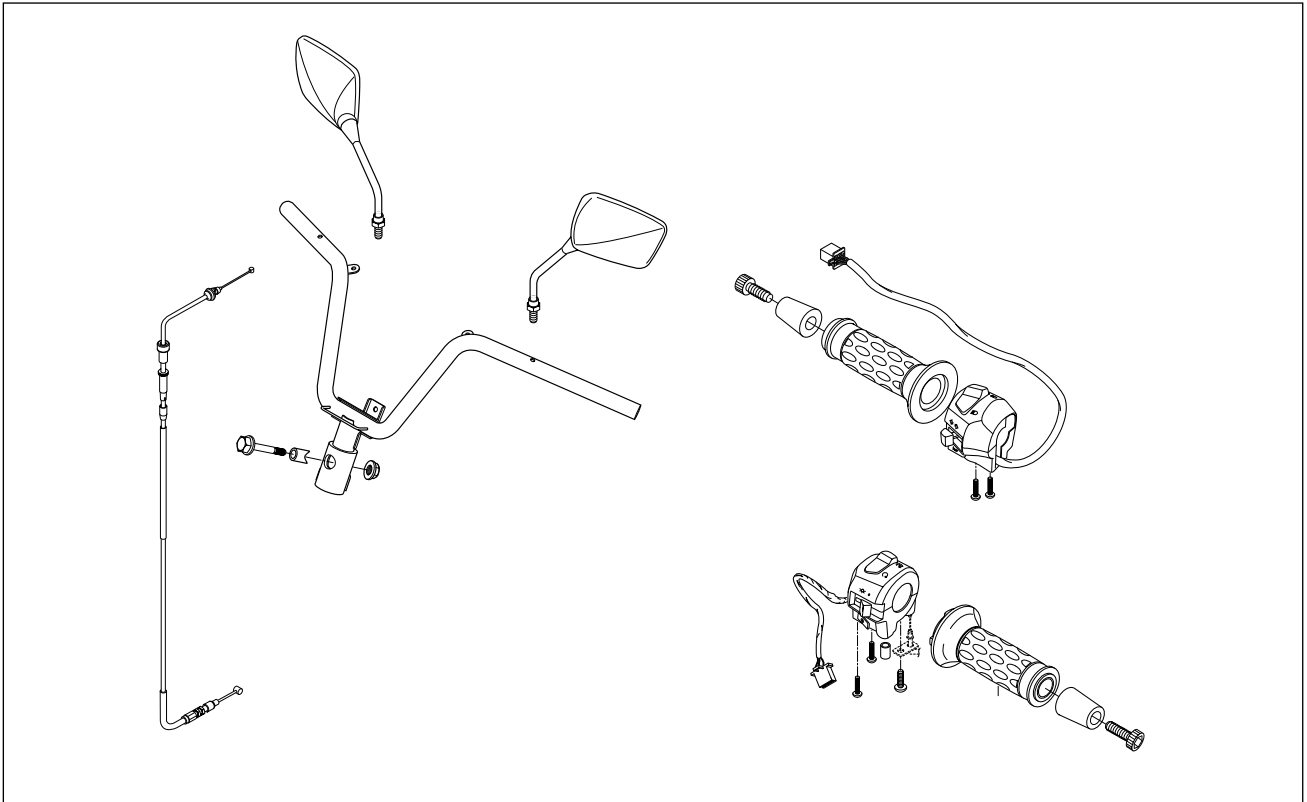

REMOVAL

- Remove the rearview mirror.
- Remove the handle cover. (Refer to page 8-1)
- Remove the left handle switches ① .
- Disconnect the rear brake lamp switch lead wires ② and remove the master cylinder ③ . (Refer to page 8-20)
- Remove the handlebar balancer and grip ④ .

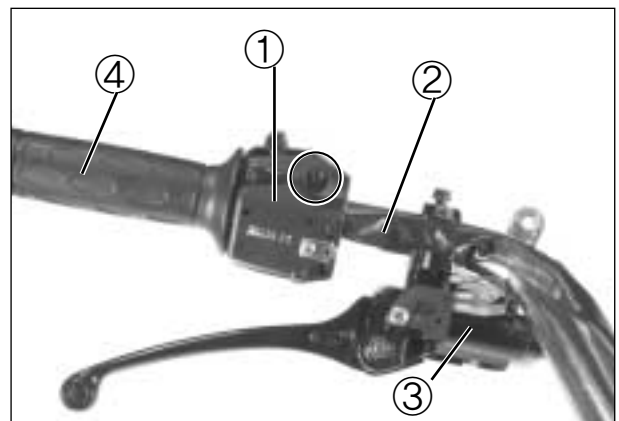

- Remove the rearview mirror.
- Remove the right handle switches ⑤ .
- Disconnect the front brake lamp switch lead wires ⑥ and remove the master cylinder ⑦ . (Refer to page 8-20)
- Remove the handlebar balancer and grip ⑧ .

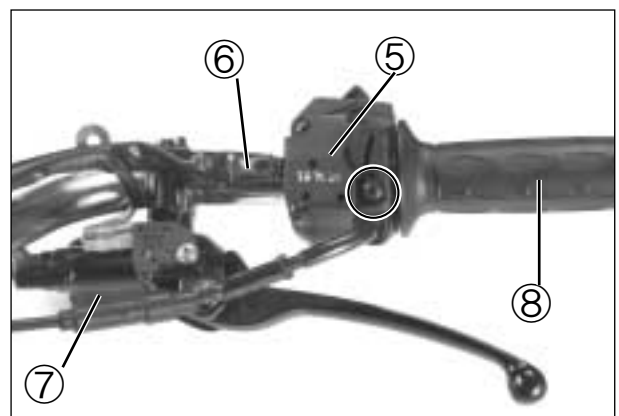

- Remove the handlebar by removing the handlebar set bolt ①.

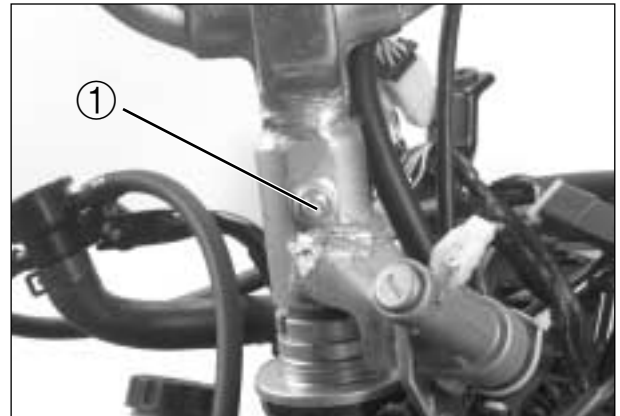

◎ REASSEMBLY

Reassemble the handlebars in the reverse order of removal.

Pay attention to the following points :

- Tighten the handlebar set bolt ① to the specified torque.

🔧 Handlebar set bolt

: 40 ~ 50 N · m (4.0 ~ 5.0 kgf · m)

- With the stopper ② engaged with the handlebar hole ③, assemble the handle switch.

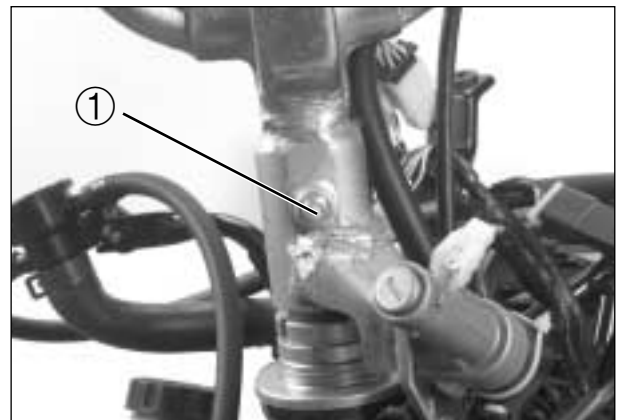

- When remounting the brake master cylinder onto the handlebars, align the brake master cylinder holder's mating surface with punch mark ④ on the handlebars.

- Tighten the master cylinder upper bolt first temporarily to provide clearance on the master cylinder lower side and then tighten both the bolts to the specification.

🔧 Master cylinder mounting bolt :

: 8 ~ 12 N · m (0.8 ~ 1.2 kgf · m)

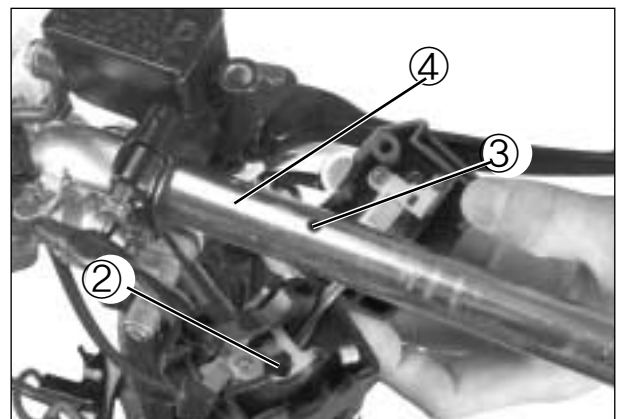

Perform the following inspections after assembly has been completed.

- * Brake Refer to page 2-18
- * Throttle operation and cable play Refer to page 2-11

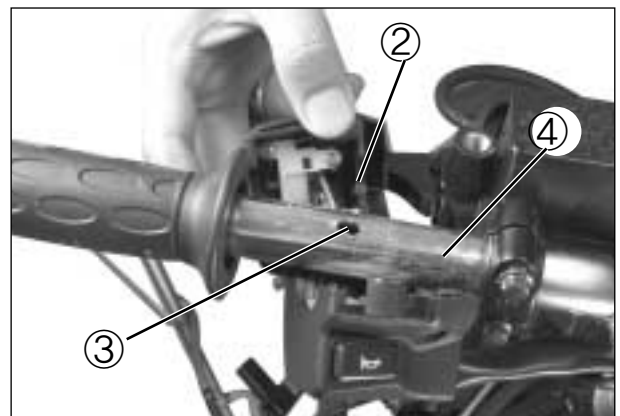

FRONT FORK

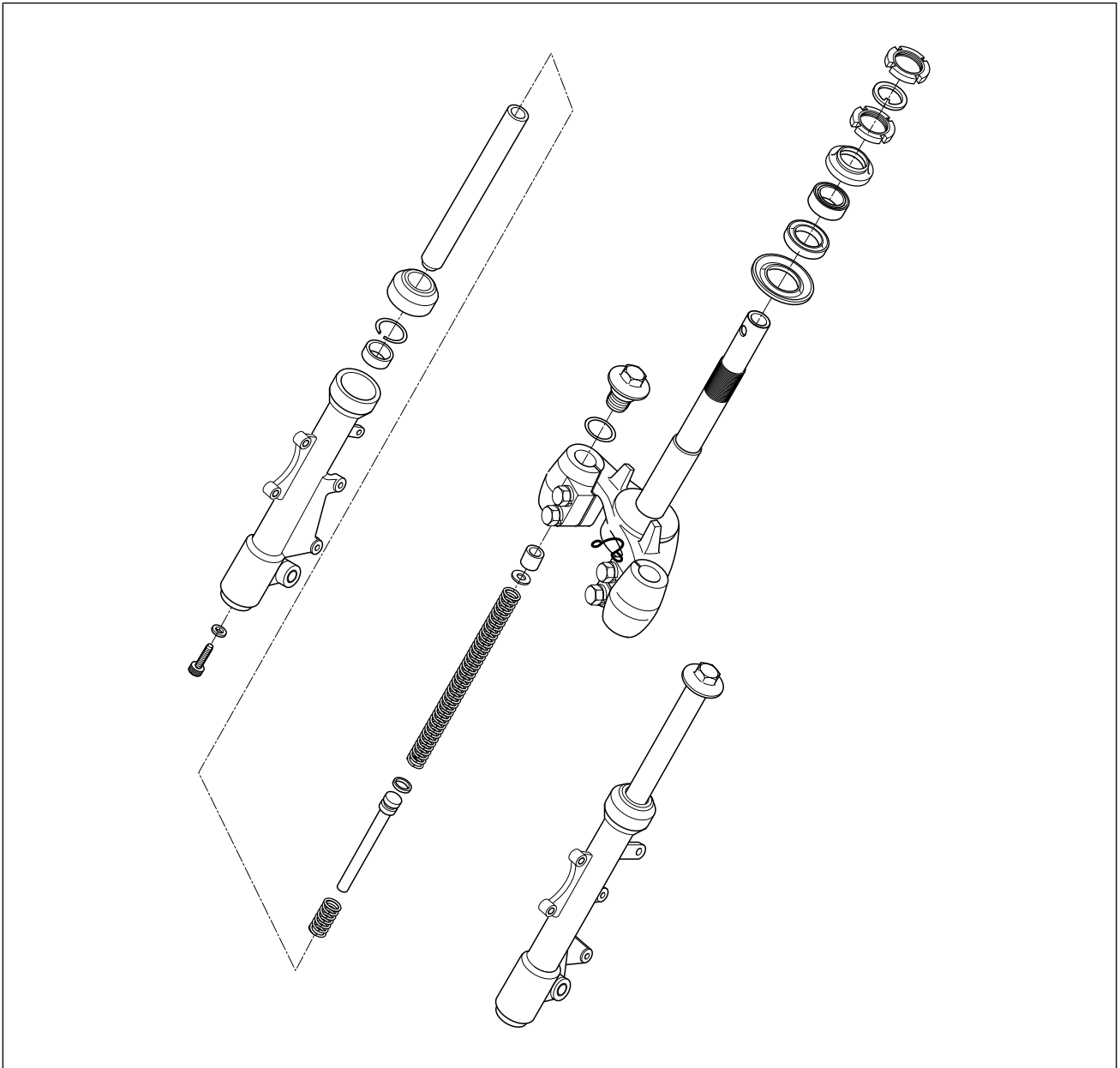

⊙ REMOVAL AND DISASSEMBLY

- Remove the front leg shield. (Refer to page 8-3)
- Remove the front brake caliper by removing the mounting bolts, right and left.

⚠ CAUTION

Do not operate the front brake lever while dismounting the caliper.



[Right front brake]

- Remove the front axle nut.
- Support the motorcycle by jack or wooden block.
- Remove the front wheel by removing the front axle shaft.

- Remove the front fender. (Refer to page 8-3)
- Loosen the front fork cap bolt ①, then draw out the fork spring.

⚠ CAUTION

Use caution when removing the front fork cap bolt since the spring force is applied to the cap bolt.

- Loosen the front fork clamp bolts ②.
- Remove the front fork.

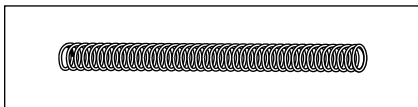

- Invert the fork and stroke it several times to remove the oil.
- Hold the fork inverted for a few minutes.

- Remove the socket bolt ③ with the hexagon wrench.
- Separate the fork pipe ④ and pipe seat ⑤.

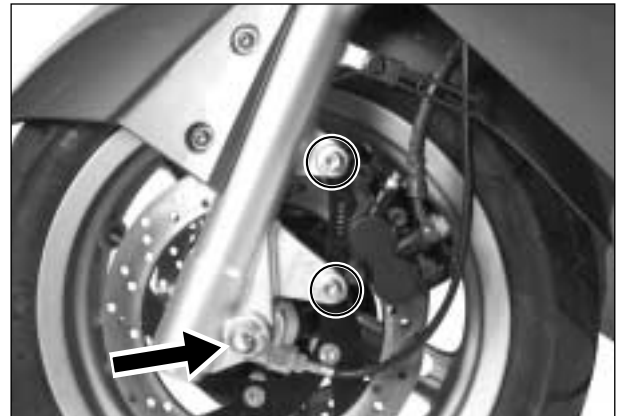

[Left front brake]

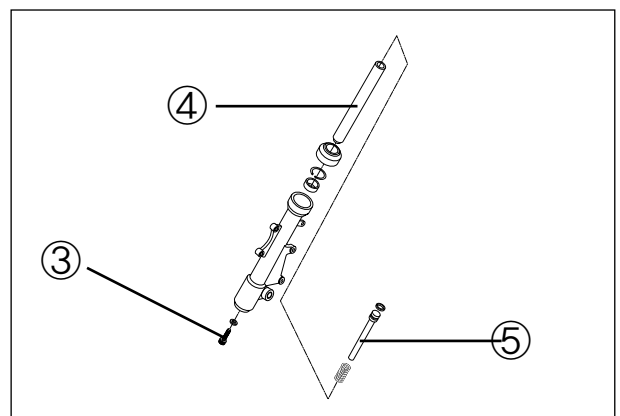
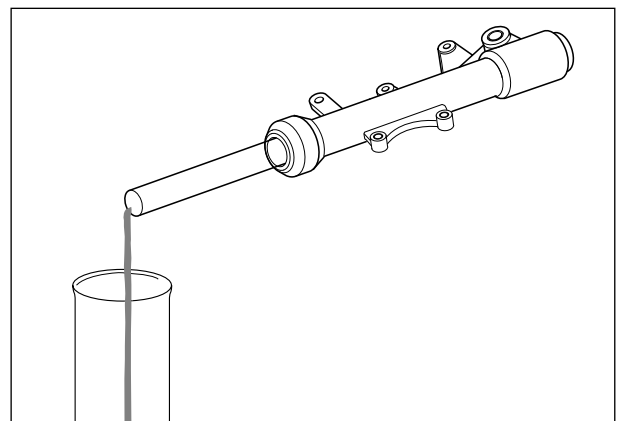
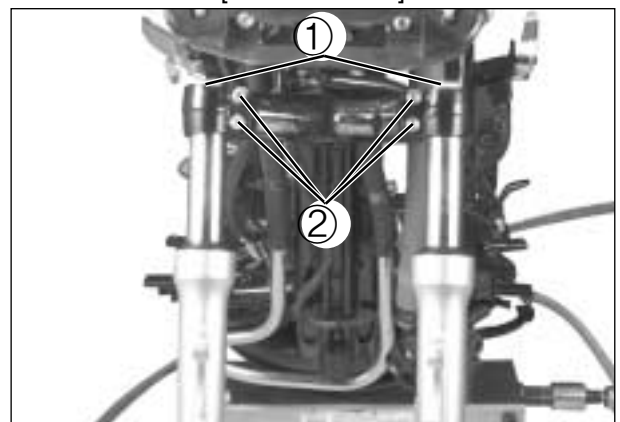

8-27 CHASSIS

- Remove the dust boot ① and stopper ring ② .

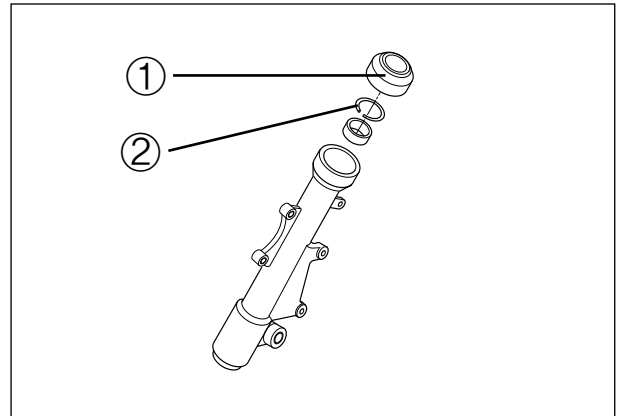

- Remove the oil seal by using the special tool.

⚠ CAUTION

The oil seal removed should be replaced with a new oil seal.

 Oil seal remover : 09913-50121

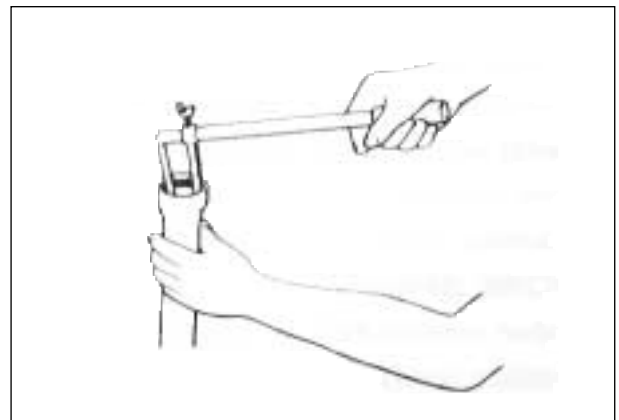

⊙ INSPECTION

- Inspect pipe seat for wear and damage.

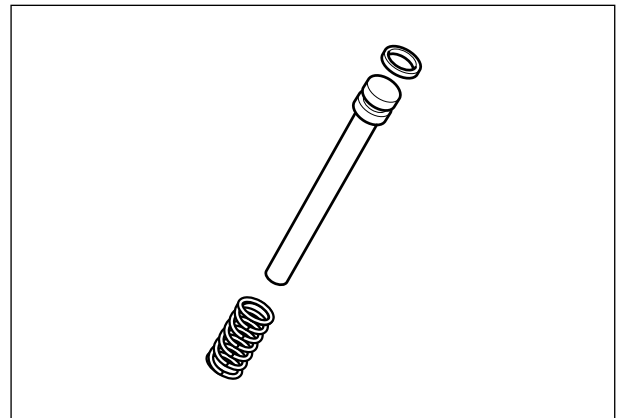

- Inspect fork pipe and bottom case sliding surfaces for any scuffing or flaws.

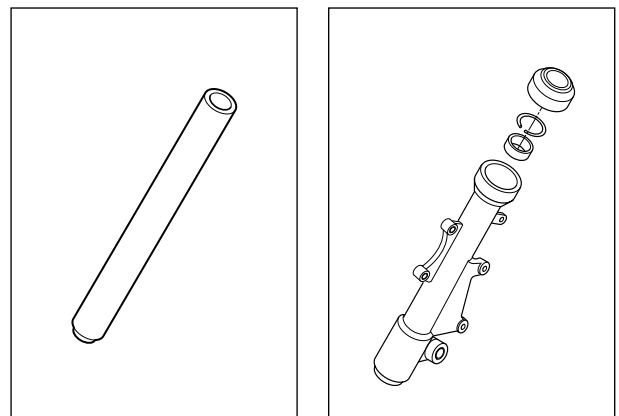

▣ FORK SPRING

- Measure the fork spring free length.

Front fork spring free length	Standard
	280.4 mm (11.04 in)

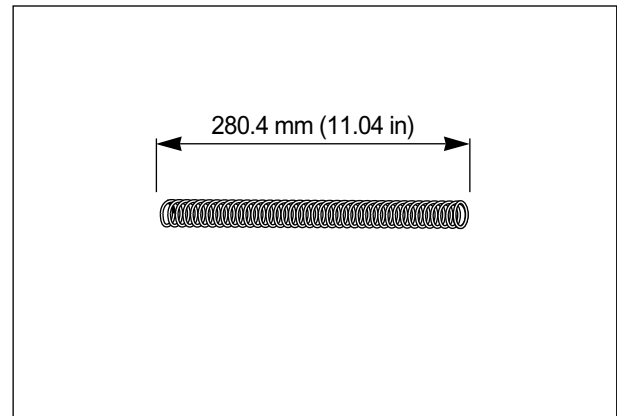

⊙ REASSEMBLY AND REMOUNTING

Reassemble and remount the fork in the reverse order of removal and disassembly, and also carry out the following steps.

▣ FRONT FORK BOLT

- Apply **BOND "1215"** and **THREAD LOCK "1324"** to the fork bolt and tighten the bolt with specified torque.

1215 BOND "1215"

1324 THREAD LOCK "1324"

U Front fork cap bolt : 46 N · m (4.6 kgf · m)

Front fork clamp bolt
: 18 ~ 28 N · m (1.8 ~ 2.8 kgf · m)

Front fork socket bolt
: 23 N · m (2.3 kgf · m)

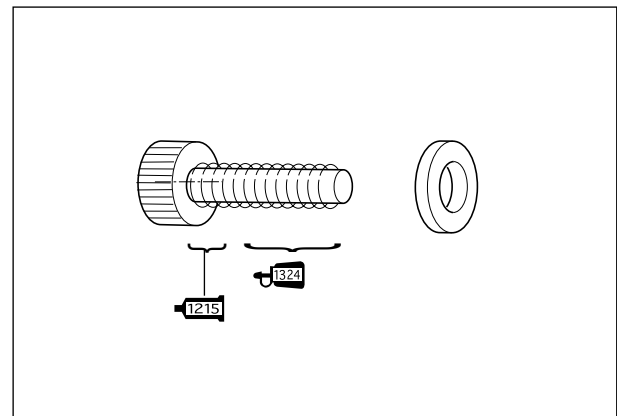

▣ FORK OIL

- For the fork oil, be sure to use a front fork oil whose viscosity rating meets specification below.

Fork oil type	TELLUS # 22
Capacity	120 cc (One side)

▣ CUSHION SPRING

- When installing the front fork spring, the close end should position upside.

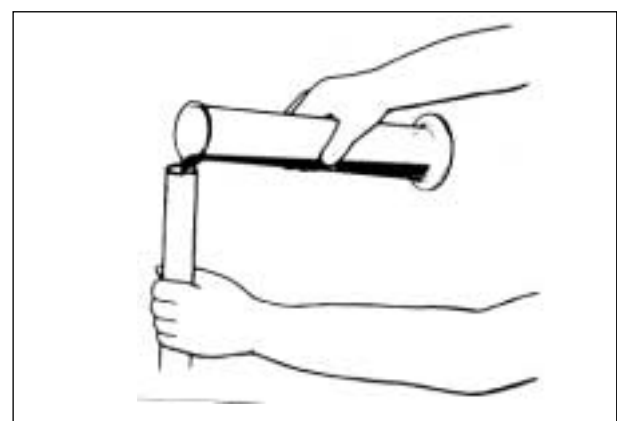

STEERING

⊙ REMOVAL AND DISASSEMBLY

- Remove the handle cover. (Refer to page 8-1)
- Remove the handlebar by removing the handlebar set bolt①.

NOTE

The front fork removal is not necessary unless the steering stem replacement or front fork disassembly work is required.

- Loosen the steering stem upper nut② using the special tool.

 **Clamp wrench : 09940-10122**

- Remove the lock washer③.
- Loosen the steering stem lower nut④ using the special tool.

 **Clamp wrench : 09940-10122**

- Remove the steering stem spacer⑤.

- Remove the steering stem upper bearing⑥.

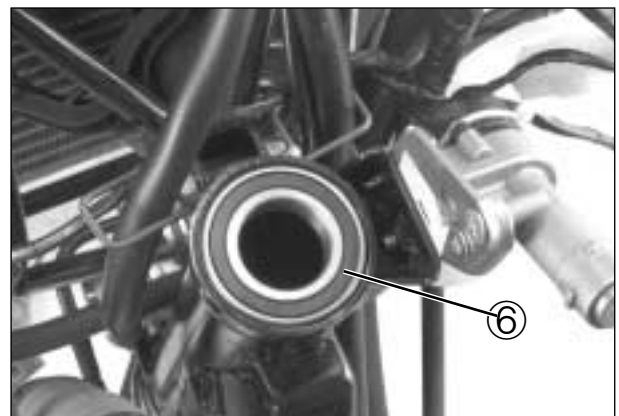
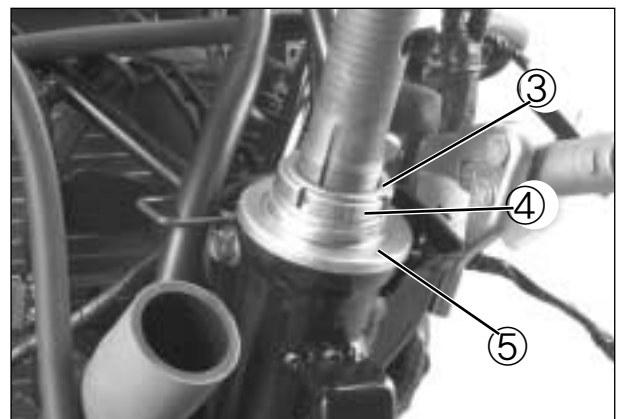
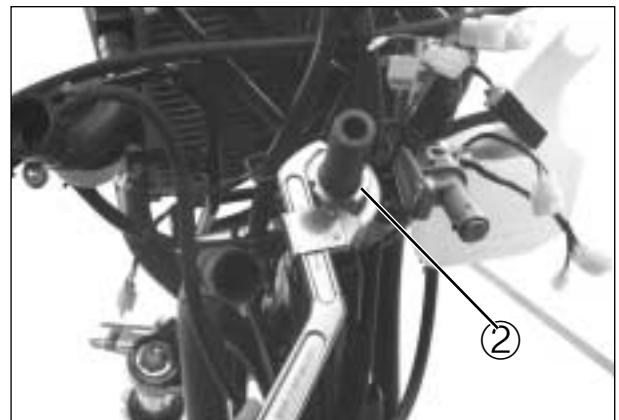
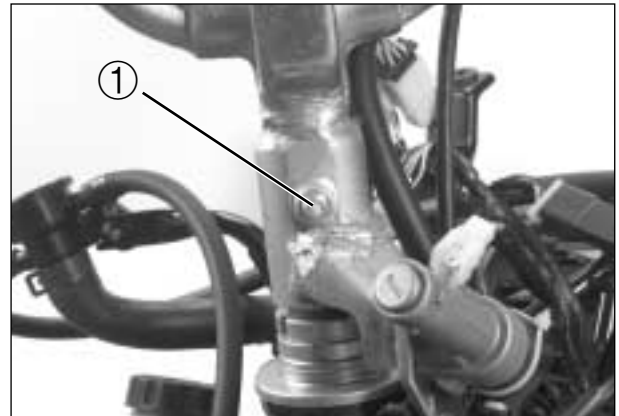

- Remove the steering stem lower bearing①.

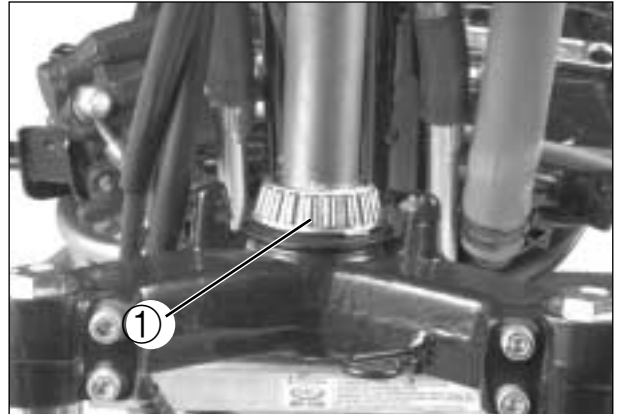

⊙ INSPECTION

Inspect the removed parts for the following abnormalities.

- Handlebar distortion
- Abnormality operation of bearing
- Distortion of steering stem

⊙ REASSEMBLY AND REMOUNTING

Reassemble and remount the steering stem in the reverse order of disassembly and removal, and also carry out the following steps.

- Apply **SUPER GREASE "A"** to the steering stem lower bearing①.

 **SUPER GREASE "A"**

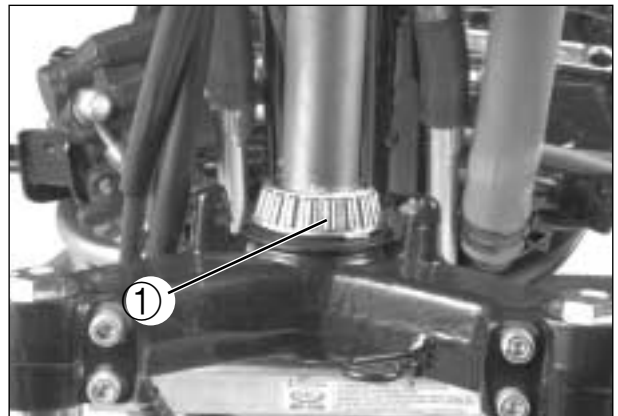

- Apply **SUPER GREASE "A"** to the steering stem upper bearing②.

 **SUPER GREASE "A"**

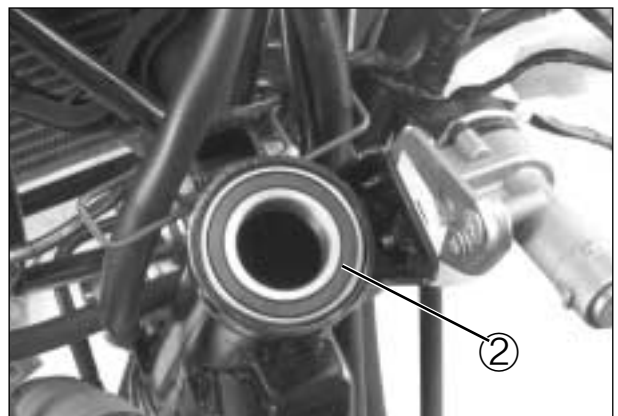

8-31 CHASSIS

- Install the steering stem spacer①.
- Tighten the steering stem lower nut ② using the special tool.

 **Clamp wrench : 09940-10122**

 **Steering stem lower nut**
: 82 N · m (8.2 kgf · m)

- Install the lock washer③.

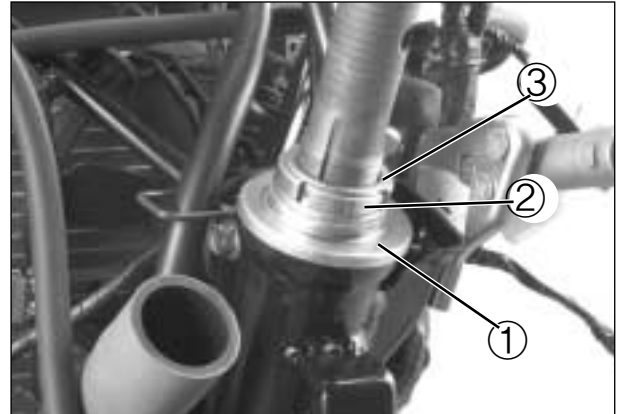

- Turn the steering stem right and left, lock-to-lock, five or six times.
- Tighten the steering stem upper nut ④ to the specified torque.

 **Clamp wrench : 09940-10122**

 **Steering stem upper nut**
: 82 N · m (8.2 kgf · m)

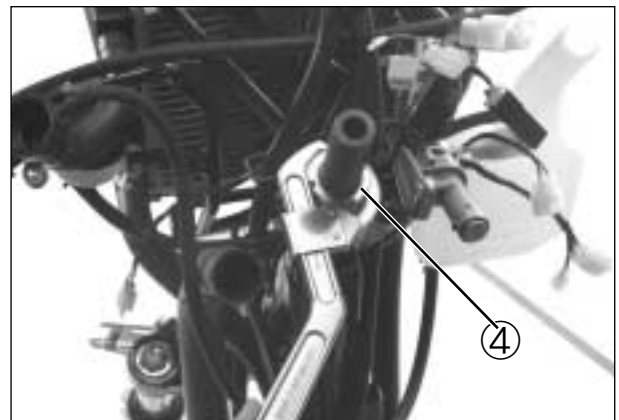

- Install the handlebar and tighten the handlebar set bolt ⑤ to the specified torque.

 **Handlebar set bolt**
: 40 ~ 50 N · m (4.0 ~ 5.0 kgf · m)

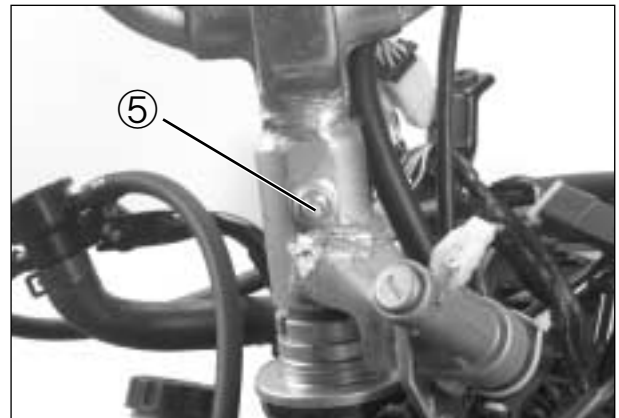

- Installed the steering stem, inspect the following items.
 - Lift the front fork.
 - Inspect play of the front fork as that grasp lower of the front fork and shake it by the front and rear.
 - By the handle turning the right or left, inspect whether turning smoothly.
 - Adjust the steering stem lower nut if the steering is comed heavy and tight.
- Bleed air of the front brake. (Refer to page 2-20)



REAR WHEEL

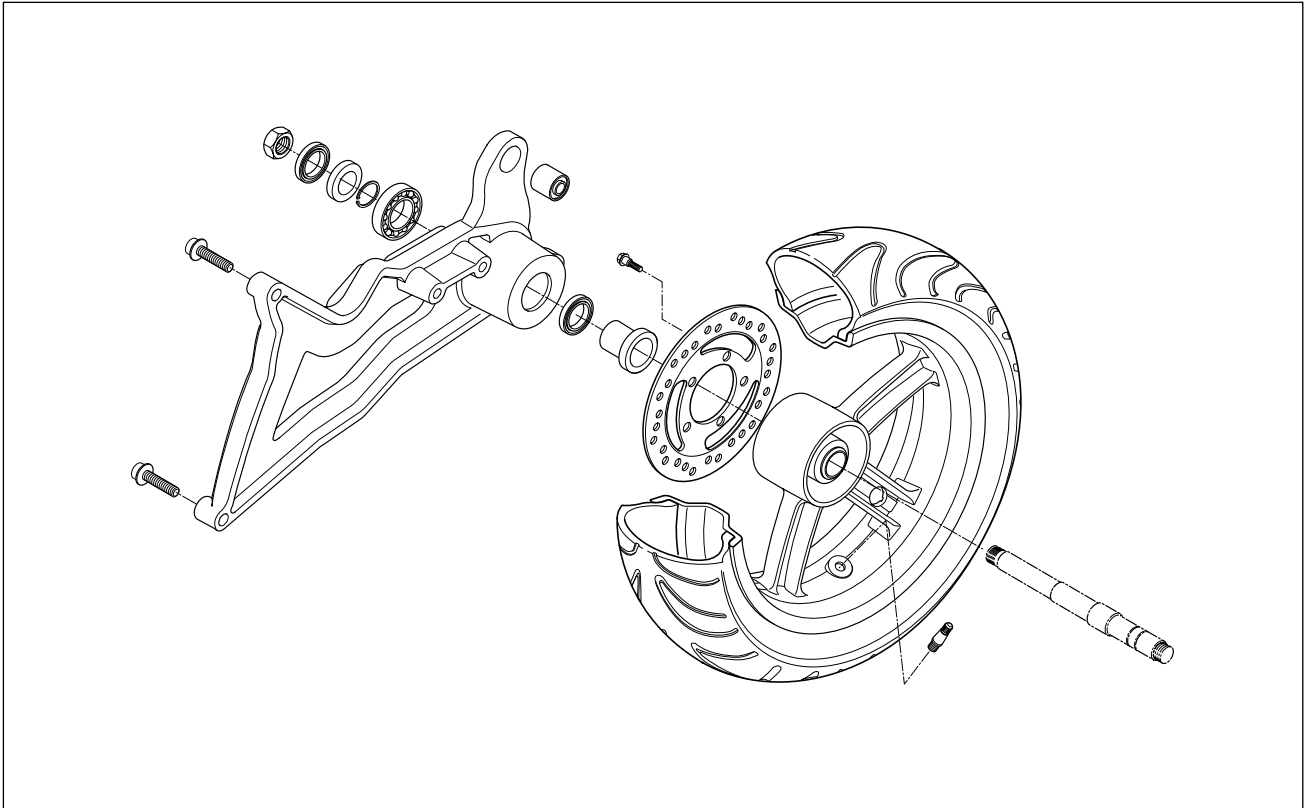

REMOVAL

- Remove the muller connecting bolt ①.

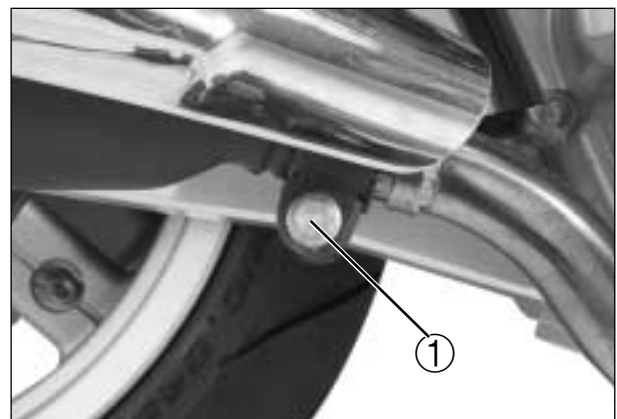

- Remove the muller mounting bolts ②, ③.
- Remove the muller.

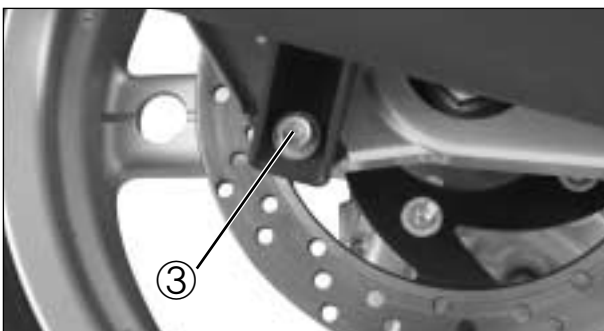

8-33 CHASSIS

- Remove the rear suspension arm ① and the rear axle nut ② .

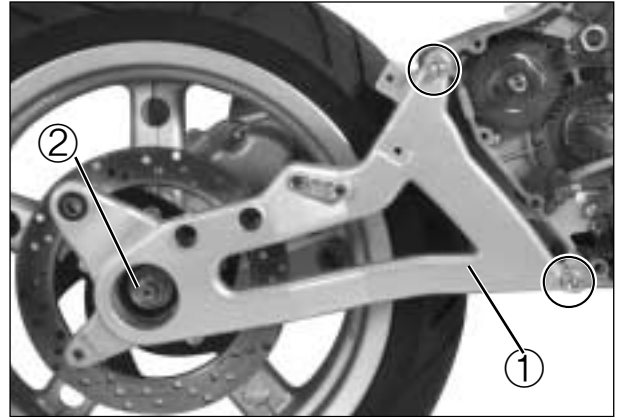

⊙ INSPECTION

WHEEL : Refer to page 8-11

WHEEL BEARING : Refer to page 8-12

TIRE : Refer to page 2-23

⊙ REMOUNTING

Remount the rear wheel in the reverse order of removal.

Pay attention to the following points :

- Install the rear wheel and tighten the rear axle nut ② to the specified torque.

🔧 Rear axle nut

: 100 ~ 140 N · m (10.0 ~ 14.0 kgf · m)

- Tighten the rear suspension arm bolts ③ to the specified torque.

🔧 Rear suspension arm bolt

: 25 ~ 35 N · m (2.5 ~ 3.5 kgf · m)

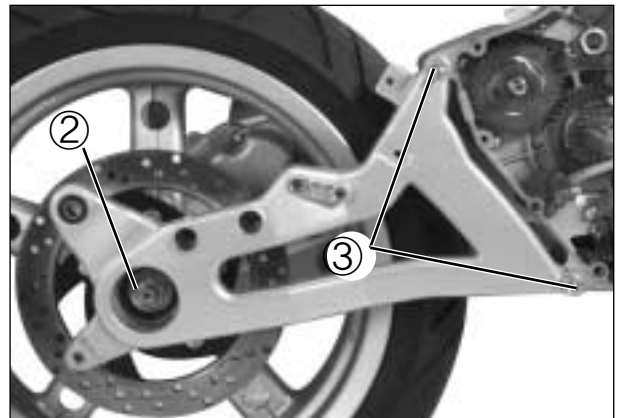

- Tighten the muffler mounting bolts ①, ② to the specified torque.

 **Muffler mounting bolt**

: 18 ~ 28 N · m (1.8 ~ 2.8 kgf · m)

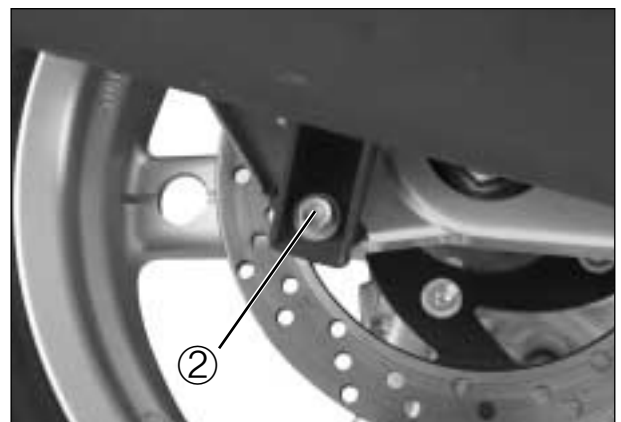
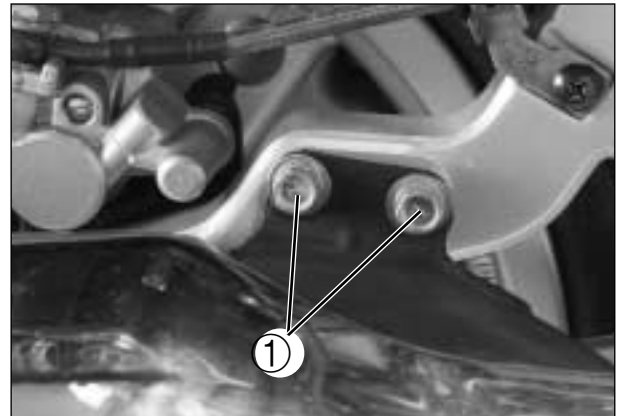

- Tighten the muffler connecting bolt ③ to the specified torque.

 **Muffler connecting bolt**

: 20 N · m (2.0 kgf · m)

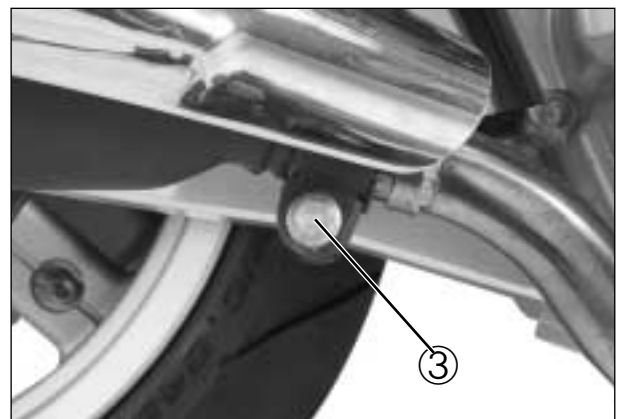

REAR BRAKE

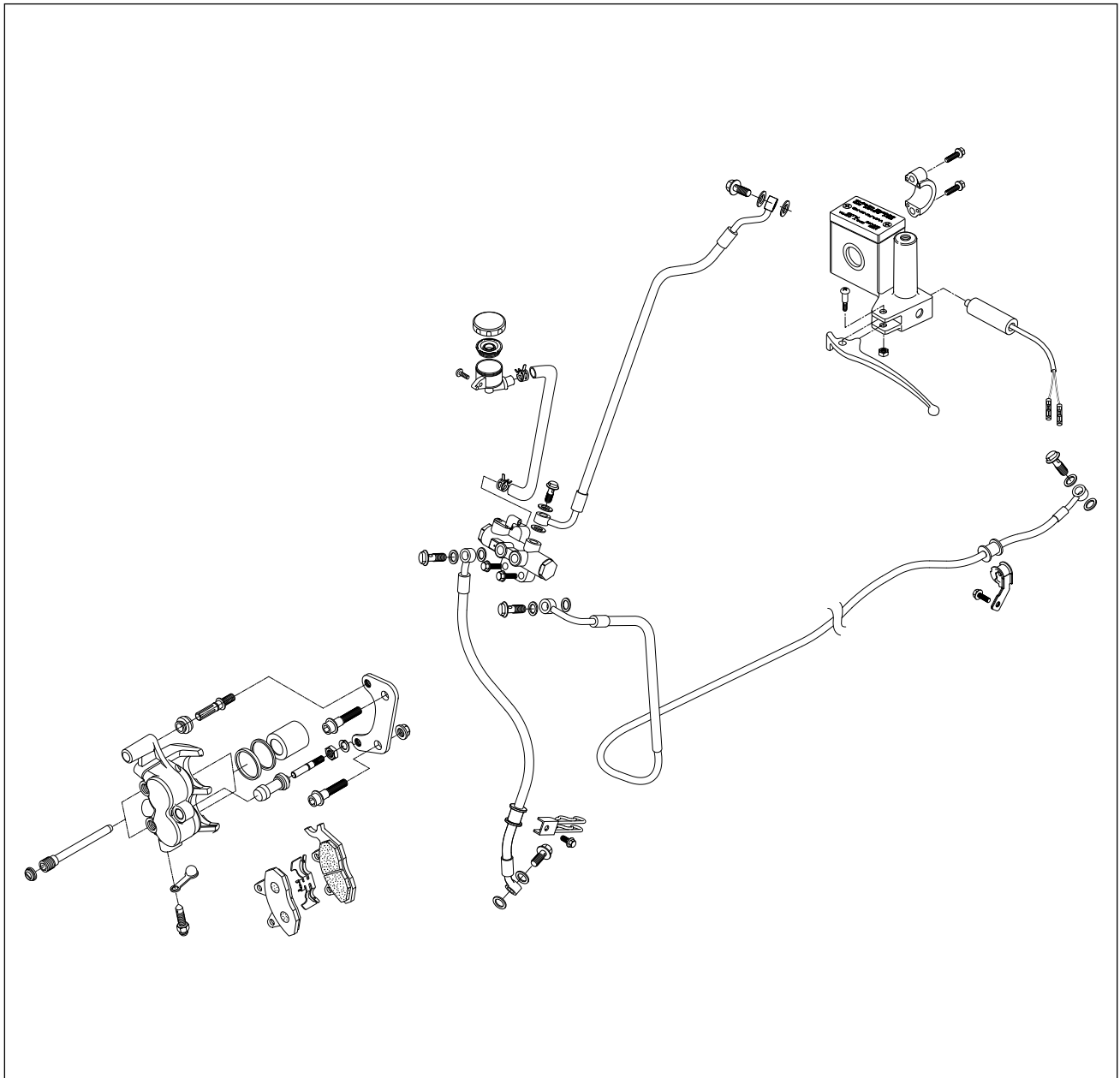

WARNING

- ❖ Do not mix brake fluid with different brand.
- ❖ Do not use a brake fluid kept in an open container or stored for a long period.
- ❖ To store brake fluid, make sure to seal the container and keep it in a safe place to be out of reach of children.
- ❖ When filling brake fluid, take care not to allow water or dirt to enter the system.
- ❖ To wash the brake system parts, use brake fluid and not any other material.
- ❖ Do not allow dirt and fluid to contact the brake disk or pad.

- Brake fluid replacement : Refer to page 2-19
- Brake pad replacement : Refer to page 2-19
- Disassembly of caliper : Refer to page 8-16
- Inspection of caliper : Refer to page 8-18
- Reassembly of caliper : Refer to page 8-18
- Inspection of brake disk : Refer to page 8-19



⊙ PRESSURE CONTROL VALVE REMOVAL

- Drain the brake fluid.
 - Place a rag underneath the brake hose union bolt on the pressure control valve to catch any split brake fluid.
- Remove the brake hose union bolts and disconnect the brake hoses.



⊙ PRESSURE CONTROL VALVE REASSEMBLY

Reassemble the pressure control valve in the reverse order of removal.

REAR SHOCK ABSORBER

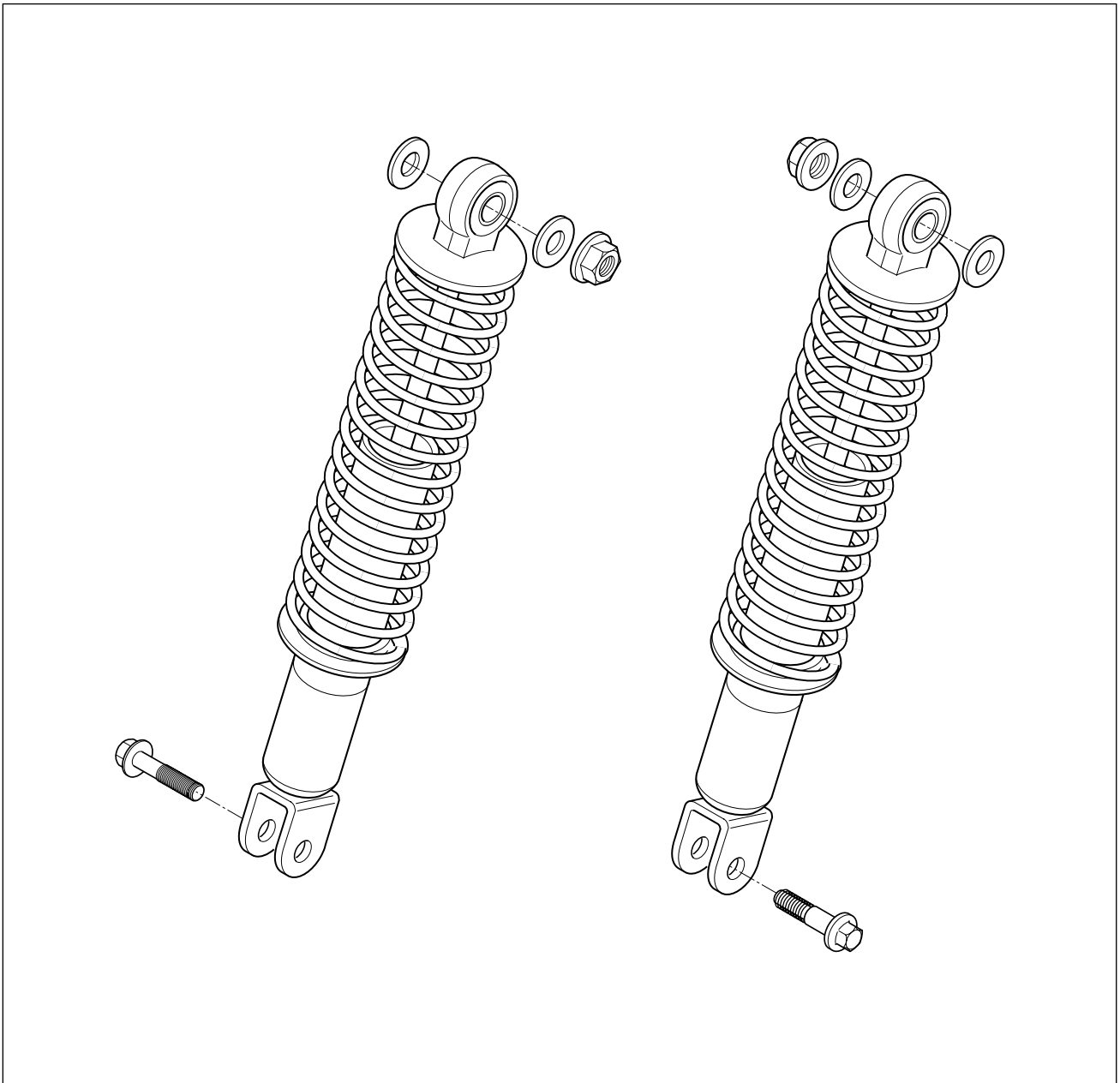

⊙ REMOVAL

- Remove the 「Seat, side cover & rear fender assembly」. (Refer to page 8-7)
- Remove the rear shock absorbers by removing their bolts and nuts.

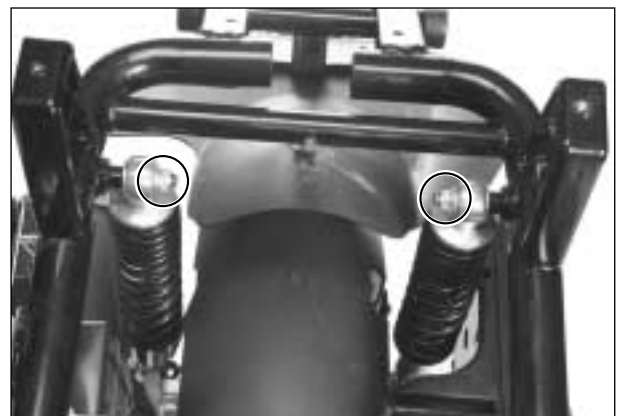



⦿ INSPECTION

Inspect the rear shock absorber for damage and oil leakage. If any defects are found, replace the rear shock absorber with a new one.

⚠ CAUTION

Do not attempt to disassemble the rear shock absorber. It is unserviceable.

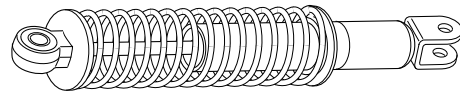

⦿ REMOUNTING

- Install the rear shock absorber and tighten the bolts and nuts to the specified torque.

🔧 Shock absorber mounting bolt (upper)
: 40 ~ 50 N · m (4.0 ~ 5.0 kgf · m)

Shock absorber mounting bolt (lower)
: 25 ~ 35 N · m (2.5 ~ 3.5 kgf · m)

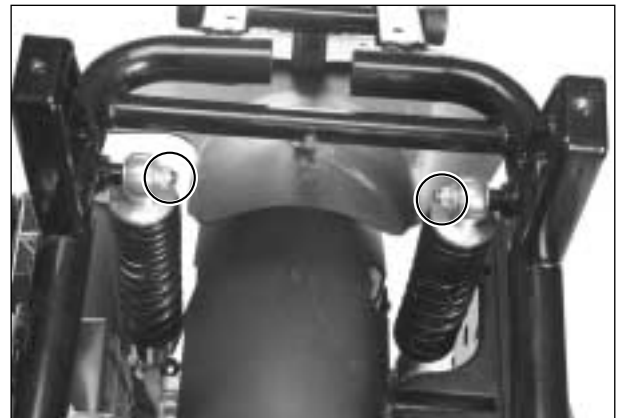

SERVICING INFORMATION

CONTENTS

TROUBLESHOOTING	9- 1
SPECIAL TOOLS	9-13
TIGHTENING TORQUE	9-16
SERVICE DATA	9-18
WIRE AND CABLE ROUTING	9-31
WIRING DIAGRAM	9-35

TROUBLESHOOTING

⊙ MALFUNCTION CODE AND DEFECTIVE CONDITION

MALFUNCTION CODE	DETECTED ITEM	DETECTED FAILURE CONDITION
		CHECK FOR
C14	Throttle position sensor (TPS)	The sensor should produce following voltage. $0.1 \text{ V} \leq \text{sensor voltage} < 4.8 \text{ V}$ Without the above range for 4 sec. and more, C14 is indicated.
		Throttle position sensor, lead wire / coupler connection.
C15	Water temperature sensor (WTS)	The sensor voltage should be the following. $0.1 \text{ V} \leq \text{sensor voltage} < 4.6 \text{ V}$ Without the above range for 4 sec. and more, C15 is indicated.
		Water temperature sensor, lead wire / coupler connection.
C17	Intake air pressure sensor (IAPS)	The sensor should produce following voltage. $0.1 \text{ V} \leq \text{sensor voltage} \leq 4.8 \text{ V}$ Without the above range for 4 sec. and more, C17 is indicated.
		Intake air pressure sensor, lead wire / coupler connection.
C21	Intake air temperature sensor (IATS)	The sensor voltage should be the following. $0.1 \text{ V} \leq \text{sensor voltage} < 4.6 \text{ V}$ Without the above range for 4 sec. and more, C21 is indicated.
		Intake air temperature sensor, lead wire / coupler connection.
C22	Oxygen sensor (O ₂ S)	The oxygen sensor signal is input in ECU since then 120 sec after the engine run. When this is the case, ECU not receive the signal, C22 is indicated.
		Oxygen sensor, lead wire / coupler connection.
C23	Tip over sensor (TOS)	The sensor voltage should be the following for more than 2 sec. after ignition switch turns "⊙" (ON) position. $4.5 \text{ V} \leq \text{sensor voltage} \leq 5.5 \text{ V}$ Without the above value for 2 sec. and more, C23 is indicated.
		Tip over sensor, lead wire / coupler connection.

MALFUNCTION CODE	DETECTED ITEM	DETECTED FAILURE CONDITION
		CHECK FOR
C24	Ignition coil (IG coil)	When the IC of the ECU electric current gets 6A and more, C24 is indicated.
		Ignition coil, wiring / coupler connection, power supply from the battery.
C27	Idle speed control solenoid (ISC solenoid)	The idle speed control solenoid step should be the following. 0 step \leq solenoid step \leq 100 step Without the above range, C27 is indicated.
		Idle speed control solenoid, lead wire / coupler connection.
C32	Fuel injector	The fuel injector not comes in voltage from the battery, C32 is indicated.
		Injector, wiring / coupler connection, power supply to the injector.
C37	Secondary air valve solenoid (SAV solenoid)	When the secondary air valve solenoid voltage is not input in ECU, C37 is indicated.
		Secondary air valve solenoid, lead wire / coupler connection.
C41	Fuel pump relay	No voltage is applied to the injector for 3 sec. after the contact of fuel pump relay is turned "ON" position. Or voltage is applied to the injector, when the contact of fuel pump is "OFF" position.
		Fuel pump relay, connecting lead wire, power source to fuel pump relay, fuel injector.
C43	Oxygen sensor heater (O ₂ S heater)	The oxygen sensor heater signal is not input in ECU.
		Oxygen sensor heater, lead wire / coupler connection.

Complaint	Symptom and possible causes	Remedy
<p>Engine idles poorly.</p>	<ol style="list-style-type: none"> 1. Tappet clearance out of adjustment. 2. Poor seating of valves. 3. Defective valve guides. 4. Worn down camshafts. 5. Too wide spark plug gap. 6. Defective ignition coil. 7. Defective pick-up coil. 8. Defective ECU. 9. Defective TP sensor. 10. Defective fuel pump. 11. Imbalanced throttle valve or SAV solenoid. 12. Damaged or cracked vacuum hose. 	<p>Adjust. Replace or repair. Replace. Replace. Adjust or replace. Replace. Replace. Replace. Replace. Replace. Adjust. Replace.</p>
<p>Engine stalls often</p>	<p>Incorrect fuel / air mixture</p> <ol style="list-style-type: none"> 1. Defective IAP sensor or circuit. 2. Clogged fuel filter. 3. Defective fuel pump. 4. Defective fuel pressure regulator. 5. Defective WT sensor. 6. Defective thermostat. 7. Defective IAT sensor. 8. Damaged or cracked vacuum hose. <p>Fuel injector improperly operating</p> <ol style="list-style-type: none"> 1. Defective fuel injector. 2. No injection signal from ECU. 3. Open or short circuited wiring connection. 4. Defective battery or low battery voltage. <p>Control circuit or sensor improperly operating</p> <ol style="list-style-type: none"> 1. Defective ECU. 2. Defective fuel pressure regulator. 3. Defective TP sensor. 4. Defective IAT sensor. 5. Defective pick-up coil. 6. Defective WT sensor. 7. Defective fuel pump relay. <p>Engine internal parts improperly operating</p> <ol style="list-style-type: none"> 1. Fouled spark plug. 2. Defective pick-up coil or ECU. 3. Clogged fuel hose. 4. Tappet clearance out of adjustment. 	<p>Repair or replace. Clean or replace. Replace. Replace. Replace. Replace. Replace. Replace. Replace.</p> <p>Replace. Repair or replace. Repair or replace. Replace or recharge.</p> <p>Replace. Replace. Replace. Replace. Replace. Replace. Replace.</p> <p>Clean. Replace. Clean. Adjust.</p>

9-5 SERVICING INFORMATION

Complaint	Symptom and possible causes	Remedy
<p>Noisy engine.</p>	<p>Excessive valve chatter</p> <ol style="list-style-type: none"> 1. Too large tappet clearance. 2. Weakened or broken valve springs. 3. Worn tappet or cam surface. 4. Worn and burnt camshaft journal. 	<p>Adjust. Replace. Replace. Replace.</p>
	<p>Noise seems to come from piston</p> <ol style="list-style-type: none"> 1. Worn down piston or cylinder. 2. Combustion chambers fouled with carbon. 3. Worn piston pins or piston pin bore. 4. Worn piston rings or ring grooves. 	<p>Replace. Clean. Replace. Replace.</p>
	<p>Noise seems to come from cam chain</p> <ol style="list-style-type: none"> 1. Stretched chain. 2. Worn sprockets. 3. Tension adjuster not working. 	<p>Replace. Replace. Repair or replace.</p>
	<p>Noise seems to come from crankshaft</p> <ol style="list-style-type: none"> 1. Rattling bearings due to wear. 2. Worn and burnt big-end bearings. 3. Worn and burnt journal bearings. 	<p>Replace. Replace. Replace.</p>
	<p>Noise seems to come from transmission</p> <ol style="list-style-type: none"> 1. Worn or rubbing gears. 2. Worn splines. 3. Worn bearings. 	<p>Replace. Replace. Replace.</p>
	<p>Noise seems to come from water pump</p> <ol style="list-style-type: none"> 1. Too much play on pump shaft bearing. 2. Worn or damaged impeller shaft. 3. Worn or damaged mechanical seal. 4. Contact between pump case and impeller. 	<p>Replace. Replace. Replace. Replace.</p>

Complaint	Symptom and possible causes	Remedy
Engine runs poorly in high speed range.	<p>Defective engine internal / electrical parts</p> <ol style="list-style-type: none"> 1. Weakened valve springs. 2. Worn camshafts. 3. Valve timing out of adjustment. 4. Too narrow spark plug gap. 5. Ignition not advanced sufficiently due to poorly working timing advance circuit. 6. Defective ignition coil. 7. Defective pick-up coil. 8. Defective ECU. 9. Clogged fuel hose, resulting in inadequate fuel supply to injector. 10. Defective fuel pump. 11. Defective TP sensor. 12. Defective SAV solenoid. 13. Clogged air cleaner element. <p>Defective air flow system</p> <ol style="list-style-type: none"> 1. Clogged air cleaner element. 2. Defective throttle valve. 3. Sucking air from throttle body joint. 4. Defective ECU. <p>Defective control circuit or sensor</p> <ol style="list-style-type: none"> 1. Low fuel pressure. 2. Defective TP sensor. 3. Defective IAT sensor. 4. Defective pick-up coil. 5. Defective IAP sensor. 6. Defective ECU. 7. TP sensor out of adjustment. 8. Defective SAV solenoid. 	<p>Replace. Replace. Adjust. Adjust. Replace ECU.</p> <p>Replace. Replace. Replace. Clean and prime. Replace. Replace. Replace. Replace. Clean.</p> <p>Clean or replace. Adjust or replace. Repair or replace. Replace.</p> <p>Repair or replace. Replace. Replace. Replace. Replace. Replace. Adjust. Replace.</p>

9-7 SERVICING INFORMATION

Complaint	Symptom and possible causes	Remedy
<p>Engine lacks power.</p>	<p>Defective engine internal / electrical parts</p> <ol style="list-style-type: none"> 1. Loss of tappet clearance. 2. Weakened valve springs. 3. Valve timing out of adjustment. 4. Worn piston rings or cylinder. 5. Poor seating of valves. 6. Fouled spark plug. 7. Incorrect spark plug. 8. Clogged injector. 9. TP sensor out of adjustment. 10. Clogged air cleaner element. 11. Sucking air from throttle valve or vacuum hose. 12. Too much engine oil. 13. Defective fuel pump or ECU. 14. Defective pick-up coil and ignition coil. <p>Defective control circuit or sensor</p> <ol style="list-style-type: none"> 1. Low fuel pressure. 2. Defective TP sensor. 3. Defective IAT sensor. 4. Defective pick-up coil. 5. Defective IAP sensor. 6. Defective ECU. 7. TP sensor out of adjustment. 8. Defective SAV solenoid. 	<p>Adjust. Replace. Adjust. Replace. Repair. Clean or replace. Adjust or replace. Clean. Adjust. Clean. Retighten or replace. Drain out excess oil. Replace. Replace.</p> <p>Repair or replace. Replace. Replace. Replace. Replace. Replace. Adjust. Replace.</p>
<p>Engine overheats.</p>	<p>Defective engine internal parts</p> <ol style="list-style-type: none"> 1. Heavy carbon deposit on piston crowns. 2. Not enough oil in the engine. 3. Defective oil pump or clogged oil circuit. 4. Sucking air from intake pipe. 5. Use incorrect engine oil. 6. Defective cooling system. <p>Lean fuel / air mixture</p> <ol style="list-style-type: none"> 1. Short-circuited IAP sensor / lead wire. 2. Short-circuited IAT sensor / lead wire. 3. Sucking air from intake pipe joint. 4. Defective fuel injectors. 5. Defective WT sensor. 6. Defective cooling system. <p>The other factors</p> <ol style="list-style-type: none"> 1. Ignition timing too advanced due to defective timing advance system (WT sensor, pick-up coil and ECU). 	<p>Clean. Add oil. Replace or clean. Retighten or replace. Change. See radiator section.</p> <p>Repair or replace. Repair or replace. Repair or replace. Replace. Replace. Consult radiator section.</p> <p>Replace.</p>

Complaint	Symptom and possible causes	Remedy
Dirty or heavy exhaust smoke	<ol style="list-style-type: none"> 1. Too much engine oil in the engine. 2. Worn piston rings or cylinder. 3. Worn valve guides. 4. Cylinder wall scored or scuffed. 5. Worn valves stems. 6. Defective stem seals. 7. Worn side rails. 	Check with inspection window, drain out excess oil. Replace. Replace. Replace. Replace. Replace. Replace.
Slipping clutch	<ol style="list-style-type: none"> 1. Worn or damaged clutch shoes. 2. Weakened clutch shoe springs. 3. Worn clutch housing. 4. Worn or slipping drive belt. 	Replace. Replace. Replace. Replace.

⊙ RADIATOR (COOLING SYSTEM)

Complaint	Symptom and possible causes	Remedy
Engine overheats.	<ol style="list-style-type: none"> 1. Not enough engine coolant. 2. Radiator core clogged with dirt or scale. 3. Faulty cooling fan. 4. Defective cooling fan thermo-switch. 5. Clogged water passage. 6. Air trapped in the cooling circuit. 7. Defective water pump. 8. Use of incorrect engine coolant. 9. Defective thermostat. 	Add coolant. Clean. Repair or replace. Replace. Clean. Bleed out air. Replace. Replace. Replace.
Engine overcools.	<ol style="list-style-type: none"> 1. Defective cooling fan thermo-switch. 2. Extremely cold weather. 3. Defective thermostat. 	Replace. Put on the radiator cover. Replace.

⊙ ELECTRICAL

Complaint	Symptom and possible causes	Remedy
<p>No sparking or poor sparking.</p>	<ol style="list-style-type: none"> 1. Defective ignition coil or spark plug cap. 2. Defective spark plug. 3. Defective pick-up coil. 4. Defective ECU. 5. Defective To sensor. 6. Open-circuited wiring connections. 	<p>Replace. Replace. Replace. Replace. Replace. Check and repair.</p>
<p>Spark plug soon become fouled with carbon.</p>	<ol style="list-style-type: none"> 1. Mixture too rich. 2. Idling speed set too high. 3. Incorrect gasoline. 4. Dirty element in air cleaner. 5. Spark plug too cold. 	<p>Inspect FI system. Adjust fast idle or throttle stop screw. Change. Clean or replace. Replace by hot type plug.</p>
<p>Spark plug become fouled too soon.</p>	<ol style="list-style-type: none"> 1. Worn piston rings. 2. Pistons or cylinder worn. 3. Excessive clearance of valve stems in valve guides. 4. Worn stem oil seal. 	<p>Replace. Replace. Replace. Replace.</p>
<p>Spark plug electrodes overheat or burn.</p>	<ol style="list-style-type: none"> 1. Spark plug too hot. 2. The engine overheats. 3. Spark plug loose. 4. Mixture too lean. 	<p>Replace by cold type plug. Tune up. Retighten. Adjust carburetor.</p>
<p>Magneto charge, but charging rate is below the specification.</p>	<ol style="list-style-type: none"> 1. Lead wires tend to get shorted or open-circuited or loosely connected at terminals. 2. Grounded or open-circuited stator coils of magneto. 3. Defective regulator / rectifier. 4. Defective cell plates in the battery. 	<p>Repair or retighten. Replace. Replace. Replace the battery.</p>
<p>Magneto overcharges.</p>	<ol style="list-style-type: none"> 1. Internal short - circuit in the battery. 2. Resistor element in the regulator / rectifier damaged or defective. 3. Regulator / rectifier poorly grounded. 	<p>Replace the battery. Replace. Clean and tighten ground connection.</p>
<p>Magneto does not charge.</p>	<ol style="list-style-type: none"> 1. Open - or short - circuited lead wire, or loose lead connections. 2. Short - circuited, grounded or open stator coil. 3. Short - circuited or punctured regulator / rectifier. 	<p>Repair or replace or retighten. Replace. Replace.</p>
<p>Unstable charging.</p>	<ol style="list-style-type: none"> 1. Lead wire insulation frayed due to vibration resulting in intermittent shorting. 2. Magneto internally shorted. 3. Defective regulator / rectifier. 	<p>Repair or replace Replace. Replace.</p>
<p>Starter switch is not effective.</p>	<ol style="list-style-type: none"> 1. Battery run down. 2. Defective switch contacts. 3. Brushes not seating properly on commutator in starter motor. 4. Defective starter relay. 5. Defective main fuse. 	<p>Recharge or replace. Replace. Repair or replace. Replace. Replace.</p>

◎ BATTERY

Complaint	Symptom and possible causes	Remedy
“Sulfation”, acidic white powdery substance or spots on surface of cell plates.	1. Cracked battery case. 2. Battery has been left in a run-down condition for a long time.	Replace the battery. Replace the battery.
Battery runs down quickly.	1. Trouble in charging system. 2. Cell plates have lost much of their active material as a result of overcharging. 3. Internal short - circuit in the battery. 4. Too low battery voltage. 5. Too old battery.	Check the generator, regulator / rectifier and circuit connections and make necessary adjustments to obtain specified charging operation. Replace and correct the charging system. Replace. Recharge fully. Replace.
Battery “Sulfation”.	1. Incorrect charging rate. (When not in use battery should be checked at least once a month to avoid sulfation.) 2. The battery was left unused in a cold climate for too long.	Replace. Replace if badly sulfated.









⊙ CHASSIS







Complaint	Symptom and possible causes	Remedy
Steering feels too heavy or stiff.	<ol style="list-style-type: none"> 1. Steering stem nut overtightened. 2. Worn bearing or race in steering stem. 3. Distorted steering stem. 4. Not enough pressure in tires. 	Adjust. Replace. Replace. Adjust.
Steering oscillation.	<ol style="list-style-type: none"> 1. Loss of balance between right and left front suspensions. 2. Distorted front fork. 3. Distorted front axle or crooked tire. 4. Loose steering stem nut. 5. Worn or incorrect tire or wrong tire pressure. 6. Worn bearing / race in steering stem. 	Replace. Repair or replace. Replace. Adjust. Adjust or replace. Replace.
Wobbling front wheel.	<ol style="list-style-type: none"> 1. Distorted wheel rim. 2. Worn-down wheel bearings. 3. Defective or incorrect tire. 4. Loosen nut on axle. 5. Incorrect front fork oil level. 6. Incorrect front wheel weight balance. 	Replace. Replace. Replace. Retighten. Adjust. Adjust.
Front suspension too soft.	<ol style="list-style-type: none"> 1. Weakened springs. 2. Not enough fork oil. 3. Wrong viscous fork oil. 	Replace. Refill. Replace.
Front suspension too stiff.	<ol style="list-style-type: none"> 1. Fork oil too viscous. 2. Too much fork oil. 3. Bent front axle. 	Replace. Drain excess oil. Replace.
Noisy front suspension.	<ol style="list-style-type: none"> 1. Not enough fork oil. 2. Loosen nuts on suspension. 	Refill. Retighten.
Wobbling rear wheel.	<ol style="list-style-type: none"> 1. Distorted wheel rim. 2. Defective or incorrect tire. 3. Loosen nut on the rear shock absorber. 	Replace. Replace. Retighten.
Rear suspension too soft.	<ol style="list-style-type: none"> 1. Weakened spring of shock absorber. 2. Leakage of oil from shock absorber 	Replace. Replace.
Rear suspension too stiff.	<ol style="list-style-type: none"> 1. Worn swingarm bushing or bearing. 	Replace.
Noisy rear suspension.	<ol style="list-style-type: none"> 1. Loosen nuts on suspension. 2. Worn swingarm bushing or bearing. 	Retighten. Replace.



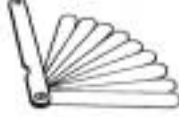
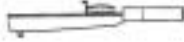
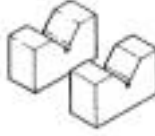



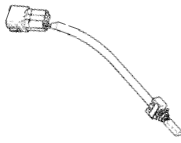

⊙ BRAKES









Complaint	Symptom and possible causes	Remedy
Poor braking (FRONT and REAR)	<ol style="list-style-type: none"> 1. Not enough brake fluid in the reservoir. 2. Air trapped in brake fluid circuit. 3. Pads worn down. 4. Too much play on brake lever. 5. Oil adhesion on friction surface of pads. 6. Worn disk. 	Refill to level mark. Bleed air out. Replace. Adjust. Clean disk and pads. Replace.
Insufficient brake power.	<ol style="list-style-type: none"> 1. Leakage of brake fluid from hydraulic system. 2. Worn pads. 3. Oil adhesion of engaging surface of pads. 4. Worn disk. 5. Air in hydraulic system. 	Repair or replace. Replace. Clean disk and pads. Replace. Bleed air.
Brake squeaking.	<ol style="list-style-type: none"> 1. Carbon adhesion on pad surface. 2. Tilted pad. 3. Damaged wheel bearing. 4. Loosen front wheel axle or rear wheel axle. 5. Worn pads. 6. Foreign material in brake fluid. 7. Clogged return port of master cylinder. 	Repair surface with sandpaper. Modify pad fitting. Replace. Tighten to specified torque. Replace. Replace brake fluid. Disassemble and clean master cylinder.
Excessive brake lever stroke.	<ol style="list-style-type: none"> 1. Air in hydraulic system. 2. Insufficient brake fluid. 3. Improper quality of brake fluid. 	Bleed air. Replenish fluid to specified level ; bleed air. Replace with correct fluid.
Leakage of brake fluid.	<ol style="list-style-type: none"> 1. Insufficient tightening of connection joints. 2. Cracked hose. 3. Worn piston and/or cup. 	Tighten to specified torque. Replace. Replace piston and/or cup.

SPECIAL TOOLS



Special tools	Part Number · Part Name · Description
	09900-20101 Vernier Calipers Used to conveniently measure various dimensions.
	09900-20201 Micrometer (0~25mm) Used for precise measurement (00~25mm measure ranges).
	09900-20202 Micrometer (25~50mm) Used for precise measurement (25~50mm measure ranges).
	09900-20203 Micrometer (50~75mm) Used for precise measurement (50~75mm measure ranges).
	09900-20204 Micrometer (75~100mm) Used for precise measurement (75~100mm measure ranges).
	09900-20508 Cylinder gauge set Measure inside diameter of cylinder.
	09900-20605 Dial calipers Measure width of conrod big-end.
	09900-20606 Dial gauge Measure oscillation of wheel with using magnetic stand.
	09900-20701 Magnetic stand With using dial gauge.

Special tools	Part Number · Part Name · Description
	09900-20806 Thickness gauge Measure clearance of piston ring.
	09900-21109 Torque wrench Measure torque of tightening.
	09900-21304 V-block With using magnetic stand.
	09900-22401 Small bore gauge Measure inside diameter of conrod small-end.
	09900-25002 Pocket tester Measure voltage, electric current, resistance.
	09900-25008 Multi circuit tester set Inspect thermo-switch or temperature switch.
	09900-26006 Engine tachometer Measure rotational frequency of engine.
	09900-27000 Mode select switch Inspect FI system sensor.
	09910-20115 Conrod holder Used to lock the crankshaft.

Special tools	Part Number · Part Name · Description
	09913-50121 Oil seal remover Used to remove the oil seal.
	09913-70122 Bearing installer Used to drive bearing in.
	09913-75820 Bearing installer Used to drive bearing in.
	09913-76010 Bearing installer Used to drive bearing in.
	09913-80112 Bearing installer Used to drive bearing in.
	09915-54510 Fuel pump pressure gauge Measure fuel pressure of fuel pump
	09915-64511 Compression gauge Measure cylinder compression.
	09916-14510 Valve spring compressor Used to remove and remounting valve stem.
	09916H35C00 (<i>MSA</i>) Valve spring compressor attachment Used with valve spring compressor.

Special tools	Part Number · Part Name · Description
	09916HG5100 (<i>MSA</i>) Valve spring compressor attachment Used with valve spring compressor.
	09920-13120 Crankcase separator Separate to crankcase.
	09921-20200 Bearing remover (10mm) Used to remove bearing with the rotor remove sliding shaft.
	09921-20210 Bearing remover (12mm) Used to remove bearing with the rotor remove sliding shaft.
	09923-73210 Bearing remover (17mm) Used to remove bearing with the rotor remove sliding shaft.
	09923-74510 Bearing remover (20~35mm) Used to remove bearing with the rotor remove sliding shaft.
	09930-30102 Rotor remove sliding shaft Used to with bearing remover.
	09930-30162 Rotor remover Attached to the top of sliding shaft when removing rotor.
	09930-40113 Rotor holder Widely used to lock rotary parts such as a flywheel magneto.

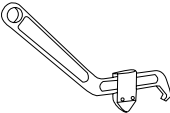
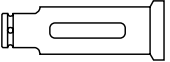
9-15 SERVICING INFORMATION

Special tools	Part Number · Part Name · Description
	09940-10122 Clamp wrench
	A hook wrench to adjust the steering head of motorcycle.
	09940HP7600 Crank balancer socket wrench
	Used to remove crank balancer drive nut.
	09941-50111 Wheel bearing remover
	Used to remove wheel bearing.

TIGHTENING TORQUE

⊙ ENGINE

ITEM	N · m	kg · m
Belt roller bolt (Only for 『MSB 350』)	8 ~ 12	0.8 ~ 1.2
Crank balancer drive gear nut	100 ~ 120	10.0 ~ 12.0
Crank balancer driven gear nut (Only for 『MSB 350』)	40 ~ 60	4.0 ~ 6.0
Coolant drain bolt	11 ~ 14	1.1 ~ 1.4
Cooling fan mounting bolt	8 ~ 12	0.8 ~ 1.2
Cooling fan motor mounting bolt	8	0.8
Cooling fan thermo-switch	13	1.3
Radiator mounting bolt	8 ~ 12	0.8 ~ 1.2
Magneto rotor nut	40 ~ 60	4.0 ~ 6.0
Magneto cover bolt	8 ~ 12	0.8 ~ 1.2
Muffler connecting bolt	20	2.0
Muffler mounting bolt	18 ~ 28	1.8 ~ 2.8
Exhaust pipe nut	23	2.3
Intake pipe bolt	8 ~ 12	0.8 ~ 1.2
Thermostat case cap bolt	8 ~ 12	0.8 ~ 1.2
Thermostat case mounting bolt	8 ~ 12	0.8 ~ 1.2
Starter clutch bolt	23 ~ 28	2.3 ~ 2.8
Starter motor mounting bolt	8 ~ 12	0.8 ~ 1.2
Cylinder head bolt	40 ~ 45	4.0 ~ 4.5
Cylinder head cover bolt	12 ~ 16	1.2 ~ 1.6
Cylinder head stud bolt	21 ~ 25	2.1 ~ 2.5
Cylinder head base nut	7 ~ 11	0.7 ~ 1.1
Cylinder base nut	7 ~ 11	0.7 ~ 1.1
Engine oil drain plug	35 ~ 45	3.5 ~ 4.5
Engine mounting bolt	40 ~ 50	4.0 ~ 5.0
Spark plug	20 ~ 25	2.0 ~ 2.5
Cam chain tension adjuster bolt	8 ~ 12	0.8 ~ 1.2
Cam chain tension adjuster mounting bolt	8 ~ 12	0.8 ~ 1.2
Crankcase bolt	8 ~ 12	0.8 ~ 1.2
Clutch shoe nut	50	5.0
Water pump case mounting bolt	8 ~ 12	0.8 ~ 1.2
Camshaft housing bolt	8 ~ 12	0.8 ~ 1.2
Clutch cover bolt	8 ~ 12	0.8 ~ 1.2
Oil pump cover mounting bolt	8 ~ 12	0.8 ~ 1.2
Oil pump mounting bolt	8 ~ 12	0.8 ~ 1.2
Clutch housing nut	60	6.0
Gear box cover bolt	18	1.8
Transmission oil level bolt	12	1.2
Transmission oil drain bolt	12	1.2
Fixed drive face nut	50	5.0

⊙ FI SYSTEM PARTS

ITEM	N · m	kg · m
Water sensor (WT sensor)	18	1.8
Intake air pressure sensor (IAP sensor) bolt	6 ~ 8	0.6 ~ 0.8
Idle speed control solenoid (ISC solenoid) bolt	6 ~ 8	0.6 ~ 0.8
Fuel injector bolt	6 ~ 8	0.6 ~ 0.8
Fuel tank mounting bolt	8 ~ 12	0.8 ~ 1.2

⊙ CHASSIS

ITEM	N · m	kg · m
Rear shock absorber mounting bolt (Upper)	40 ~ 50	4.0 ~ 5.0
Rear shock absorber mounting bolt (Lower)	25 ~ 35	2.5 ~ 3.5
Rear suspension arm bolt	25 ~ 35	2.5 ~ 3.5
Rear axle nut	100 ~ 140	10.0 ~ 14.0
Steering stem upper nut	82	8.2
Steering stem lower nut	82	8.2
Front and Rear brake disk bolt	18 ~ 28	1.8 ~ 2.8
Front and Rear brake master cylinder mounting bolt	8 ~ 12	0.8 ~ 1.2
Front and Rear brake caliper air bleeder valve	9 ~ 14	0.9 ~ 1.4
Front and Rear brake caliper mounting bolt	18 ~ 28	1.8 ~ 2.8
Front and Rear brake hose union bolt	20 ~ 25	2.0 ~ 2.5
Front axle nut	50 ~ 70	5.0 ~ 7.0
Front fork clamp bolt	18 ~ 28	1.8 ~ 2.8
Front fork cap bolt	46	4.6
Front fork socket bolt	23	2.3
Handlebar set bolt	40 ~ 50	4.0 ~ 5.0

SERVICE DATA

⊙ VALVE + GUIDE (*MSB* 250)

Unit : mm (in)

ITEM		STANDARD	LIMIT
Valve diam.	IN.	28.3 (1.11)	—
	EX.	25.0 (0.98)	—
Valve clearance (When cold)	IN.	0.1 ~ 0.2 (0.004 ~ 0.008)	—
	EX.	0.2 ~ 0.3 (0.008 ~ 0.012)	—
Valve guide to valve stem clearance	IN.	0.020 ~ 0.047 (0.0008 ~ 0.0019)	—
	EX.	0.030 ~ 0.057 (0.0012 ~ 0.0022)	—
Valve stem deflection	IN. & EX.	—	0.35 (0.014)
Valve guide I.D.	IN. & EX.	4.500 ~ 4.512 (0.1771 ~ 0.1776)	—
Valve stem O.D.	IN.	4.465 ~ 4.480 (0.1758 ~ 0.1764)	—
	EX.	4.455 ~ 4.470 (0.1754 ~ 0.1760)	—
Valve stem runout	IN. & EX.	—	0.05 (0.002)
Valve head thickness	IN. & EX.	—	0.50 (0.02)
Valve seat width		0.9 ~ 1.1 (0.035 ~ 0.043)	—
Valve seat angle	IN. & EX.	45°	
Valve head radial runout	IN. & EX.	—	0.03 (0.0012)
Valve spring free length	IN.	—	40.67 (1.601)
	EX.	—	40.67 (1.601)
Valve spring tension	IN.	18.50 ~ 21.50 kgf (40.79 ~ 47.40 lbs) at length 31.8 mm (1.25 in)	—
	EX.	18.50 ~ 21.50 kgf (40.79 ~ 47.40 lbs) at length 31.8 mm (1.25 in)	—

9-19 SERVICING INFORMATION

⊙ VALVE + GUIDE (*MSA 129*)

Unit : mm (in)

ITEM		STANDARD	LIMIT
Valve diam.	IN.	22.0 (0.87)	—
	EX.	19.0 (0.75)	—
Valve clearance (When cold)	IN.	0.1 ~ 0.2 (0.004 ~ 0.008)	—
	EX.	0.2 ~ 0.3 (0.008 ~ 0.012)	—
Valve guide to valve stem clearance	IN.	0.010 ~ 0.037 (0.0004 ~ 0.0015)	—
	EX.	0.030 ~ 0.057 (0.0012 ~ 0.0022)	—
Valve stem deflection	IN. & EX.	—	0.35 (0.014)
Valve guide I.D.	IN. & EX.	4.500 ~ 4.512 (0.1771 ~ 0.1776)	—
Valve stem O.D.	IN.	4.475 ~ 4.490 (0.1762 ~ 0.1768)	—
	EX.	4.455 ~ 4.470 (0.1754 ~ 0.1760)	—
Valve stem runout	IN. & EX.	—	0.05 (0.002)
Valve head thickness	IN. & EX.	—	0.50 (0.02)
Valve seat width		0.9 ~ 1.1 (0.035 ~ 0.043)	—
Valve seat angle	IN. & EX.	45°	
Valve head radial runout	IN. & EX.	—	0.03 (0.0012)
Valve spring free length	IN.	—	39.35 (1.549)
	EX.	—	39.35 (1.549)
Valve spring tension	IN.	12.35 ~ 13.65 kgf (27.23 ~ 30.09 lbs) at length 33.7 mm (1.33 in)	—
	EX.	12.35 ~ 13.65 kgf (27.23 ~ 30.09 lbs) at length 33.7 mm (1.33 in)	—

⊙ CYLINDER + PISTON + PISTON RING (*MSB* ESD)

Unit : mm (in)

ITEM	STANDARD		LIMIT
Compression pressure	11 kgf/cm ² (at 500 rpm)		10 kgf/cm ²
Piston to cylinder clearance	0.050 ~ 0.060 (0.0020 ~ 0.0024)		0.120 (0.0047)
Cylinder bore	73.000 ~ 73.015 (2.8740 ~ 2.8746)		73.080 (2.8772)
Piston diam.	72.945 ~ 72.960 (2.8719 ~ 2.8724) (Measure at 15 mm (0.6 in) from the skirt end)		72.880 (2.8693)
Cylinder distortion	—		0.05 (0.002)
Piston ring free end gap	1st	Approx 9.5 (0.374)	8.0 (0.315)
	2nd	Approx 8.0 (0.315)	6.8 (0.268)
Piston ring end gap (Assembly condition)	1st	0.10 ~ 0.30 (0.004 ~ 0.012)	0.5 (0.020)
	2nd	0.35 ~ 0.50 (0.014 ~ 0.020)	0.5 (0.020)
Piston ring to groove clearance	1st	—	0.180 (0.007)
	2nd	—	0.150 (0.006)
Piston ring groove width	1st	1.01 ~ 1.03 (0.040 ~ 0.041)	—
	2nd	1.01 ~ 1.03 (0.040 ~ 0.041)	—
	Oil	2.01 ~ 2.03 (0.079 ~ 0.080)	—
Piston ring thickness	1st	0.970 ~ 0.990 (0.0382 ~ 0.0390)	—
	2nd	0.970 ~ 0.990 (0.0382 ~ 0.0390)	—
Piston pin hole bore	19.002 ~ 19.008 (0.7481 ~ 0.7484)		19.030 (0.7492)
Piston pin O.D.	18.996 ~ 19.000 (0.7479 ~ 0.7480)		18.980 (0.7472)

9-21 SERVICING INFORMATION

⊙ **CYLINDER + PISTON + PISTON RING** (*MSB 125*)

Unit : mm (in)

ITEM	STANDARD		LIMIT
Compression pressure	15 kgf/cm ² (at 500 rpm)		13 kgf/cm ²
Piston to cylinder clearance	0.050 ~ 0.060 (0.0020 ~ 0.0024)		0.120 (0.0047)
Cylinder bore	57.000 ~ 57.015 (2.2441 ~ 2.2447)		57.080 (2.2472)
Piston diam.	56.945 ~ 56.960 (2.2419 ~ 2.2425) (Measure at 15 mm (0.6 in) from the skirt end)		56.880 (2.2394)
Cylinder distortion	—		0.05 (0.002)
Piston ring free end gap	1st	Approx 7.2 (0.284)	5.7 (0.224)
	2nd	Approx 5.8 (0.228)	4.6 (0.181)
Piston ring end gap (Assembly condition)	1st	0.20 ~ 0.32 (0.008 ~ 0.013)	0.50 (0.020)
	2nd	0.20 ~ 0.32 (0.008 ~ 0.013)	0.50 (0.020)
Piston ring to groove clearance	1st	—	0.180 (0.007)
	2nd	—	0.150 (0.006)
Piston ring groove width	1st	1.01 ~ 1.03 (0.040 ~ 0.041)	—
	2nd	1.01 ~ 1.03 (0.040 ~ 0.041)	—
	Oil	2.01 ~ 2.03 (0.079 ~ 0.080)	—
Piston ring thickness	1st	0.970 ~ 0.990 (0.0382 ~ 0.0390)	—
	2nd	0.970 ~ 0.990 (0.0382 ~ 0.0390)	—
Piston pin hole bore	15.002 ~ 15.008 (0.5906 ~ 0.5909)		15.030 (0.5917)
Piston pin O.D.	14.994 ~ 15.000 (0.5903 ~ 0.5906)		14.980 (0.5898)

⊙ OIL PUMP (*MSB* ₂₅₀)

ITEM	STANDARD	NOTE
Oil pressure	2.0 ~ 3.0 kgf/cm ² (at 65°C (149°F), 6,000 rpm)	—
Oil pump reduction ratio	1.53 (26/17)	—

⊙ OIL PUMP (*MSB* ₁₂₅)

ITEM	STANDARD	NOTE
Oil pressure	1.5 ~ 2.5 kgf/cm ² (at 65°C (149°F), 6,000 rpm)	—
Oil pump reduction ratio	1.53 (26/17)	—

⊙ CAMSHAFT + CYLINDER HEAD (*MSB* ₂₅₀)

Unit : mm (in)

ITEM	STANDARD		LIMIT
Cam height	IN.	32.98 ~ 33.02 (1.298 ~ 1.300)	32.72 (1.288)
	EX.	32.78 ~ 32.82 (1.291 ~ 1.292)	32.52 (1.280)
Camshaft housing I.D.	IN. & EX.	21.959 ~ 21.980 (0.8645 ~ 0.8654)	—
Camshaft O.D	IN. & EX.	21.959 ~ 21.980 (0.8645 ~ 0.8654)	—
Camshaft runout	IN. & EX.	—	0.10 (0.004)
Camshaft journal oil clearance	IN. & EX.	—	0.15 (0.006)
Cylinder head distortion	—		0.05 (0.002)
Cylinder head cover distortion	—		0.05 (0.002)
Cam chain pin (Arrow "3")	16th pin		—

⊙ CAMSHAFT + CYLINDER HEAD (*MSB* ₁₂₅)

Unit : mm (in)

ITEM	STANDARD		LIMIT
Cam height	IN.	34.43 ~ 34.47 (1.356 ~ 1.357)	34.17 (1.345)
	EX.	34.38 ~ 34.42 (1.354 ~ 1.355)	34.12 (1.343)
Camshaft housing I.D.	IN. & EX.	21.959 ~ 21.980 (0.8645 ~ 0.8654)	—
Camshaft O.D	IN. & EX.	21.959 ~ 21.980 (0.8645 ~ 0.8654)	—
Camshaft runout	IN. & EX.	—	0.10 (0.004)
Camshaft journal oil clearance	IN. & EX.	—	0.15 (0.006)
Cylinder head distortion	—		0.05 (0.002)
Cylinder head cover distortion	—		0.05 (0.002)
Cam chain pin (Arrow "3")	16th pin		—

9-23 SERVICING INFORMATION

⊙ CONROD + CRANKSHAFT (*MSB 250*)

Unit : mm (in)

ITEM	STANDARD	LIMIT
Conrod small end I.D.	19.006 ~ 19.014 (0.7483 ~ 0.7486)	19.040 (0.7496)
Conrod deflection	—	3.0 (0.12)
Conrod big end side clearance	0.10 ~ 0.45 (0.004 ~ 0.018)	1.00 (0.040)
Conrod big end width	17.95 ~ 18.00 (0.707 ~ 0.709)	—
Crank web to web width	50.9 ~ 51.1 (2.004 ~ 2.012)	—
Crankshaft runout	—	0.01 (0.0004)

⊙ CONROD + CRANKSHAFT (*MSB 125*)

Unit : mm (in)

ITEM	STANDARD	LIMIT
Conrod small end I.D.	15.006 ~ 15.014 (0.5908 ~ 0.5911)	15.040 (0.5921)
Conrod deflection	—	3.0 (0.12)
Conrod big end side clearance	0.10 ~ 0.45 (0.004 ~ 0.018)	1.00 (0.040)
Conrod big end width	15.95 ~ 16.00 (0.628 ~ 0.630)	—
Crank web to web width	50.9 ~ 51.1 (2.004 ~ 2.012)	—
Crankshaft runout	—	0.03 (0.0012)

⊙ **CLUTCH (*MSB 250*)**

Unit : mm (in)

ITEM	STANDARD	LIMIT
Clutch housing I.D.	134.0 ~ 134.2 (5.276 ~ 5.284)	134.5 (5.295)
Clutch shoe thickness	—	1.0 (0.04)
Engagement rpm	1,800 ~ 2,400 rpm	—
Lock-up rpm	2,300 ~ 2,900 rpm	—

⊙ **CLUTCH (*MSB 125*)**

Unit : mm (in)

ITEM	STANDARD	LIMIT
Clutch housing I.D.	125.0 ~ 125.2 (4.921 ~ 4.929)	125.5 (4.941)
Clutch shoe thickness	—	1.0 (0.04)
Engagement rpm	3,600 ~ 4,200 rpm	—
Lock-up rpm	4,100 ~ 4,700 rpm	—

⊙ **TRANSMISSION + DRIVE BELT (*MSB 250*)**

Unit : mm (in) Except ratio

ITEM	STANDARD	LIMIT
Reduction ratio	7.31	—
Gear ratio	0.900 ~ 2.333	—
Drive belt width	23.4 (0.92)	22.5 (0.89)
Movable drive face roller O.D.	21.0 (0.83)	20.4 (0.80)
Movable driven face spring free length	127.7 (5.03)	124.0 (4.88)

⊙ **TRANSMISSION + DRIVE BELT (*MSB 125*)**

Unit : mm (in) Except ratio

ITEM	STANDARD	LIMIT
Reduction ratio	10.82	—
Gear ratio	0.804 ~ 2.414	—
Drive belt width	20.5 (0.81)	19.6 (0.77)
Movable drive face roller O.D.	17.0 (0.67)	16.4 (0.65)
Movable driven face spring free length	74.0 (2.91)	70.0 (2.76)

⊙ FI SENSORS

ITEM	SPECIFICATION		NOTE
IAP sensor input voltage	4.5 ~ 5.5 V		
IAP sensor output voltage	Approx. 4.0 ~ 4.2 V when ignition switch "⊙" (ON)		
TP sensor input voltage	4.5 ~ 5.5 V		
TP sensor resistance	Closed	Approx. 1.81 KΩ	
	Opened	Approx. 4.75 KΩ	
TP sensor output voltage	Closed	Approx. 1.12 V	
	Opened	Approx. 4.18 V	
IAT sensor voltage	4.5 ~ 5.5 V		
IAT sensor resistance	Refer to page 4-25		
TO sensor voltage	4.5 ~ 5.5 V at normal condition (To sensor switch - "ON" at leaned more than 60°)		
SAV solenoid voltage	Battery voltage		
Oxygen sensor heater voltage	Battery voltage		

⊙ THROTTLE BODY (*MS3 250*)

ITEM	SPECIFICATION	NOTE
I.D. No.	MS3-250	
Bore size	∅ 36	
Idle rpm	1,400 ~ 1,600 rpm	
Throttle cable play	0.5 ~ 1.0 mm (0.02 ~ 0.04 in)	

⊙ THROTTLE BODY (*MS3 125*)

ITEM	SPECIFICATION	NOTE
I.D. No.	MS3-125	
Bore size	∅ 28	
Idle rpm	1,350 ~ 1,550 rpm	
Throttle cable play	0.5 ~ 1.0 mm (0.02 ~ 0.04 in)	

⊙ FUEL INJECTOR + FUEL PUMP

ITEM	SPECIFICATION	NOTE
Fuel injector resistance	11.5 ~ 13.5 Ω at 20°C (68°F)	
Fuel injector voltage	Battery voltage	
Fuel pressure	Approx. 3.4 ~ 3.7 kgf/cm ² (333 ~ 363 kPa, 48.4 ~ 52.6 psi)	

⊙ THERMOSTAT + COOLING FAN + COOLANT

ITEM	STANDARD		LIMIT
Thermostat valve operating temperature	Valve opening	76°C (169°F)	
	Valve full open	90°C (194°F)	
	Valve closing	71°C (160°F)	
Thermostat valve lift	Over 8mm (0.32 in) / 90°C (194°F)		
WT sensor voltage	4.5 ~ 5.5 V		
WT sensor resistance (To ECU)	0°C (32°F)	Approx. 5.790 KΩ	
	20°C (68°F)	Approx. 2.450 KΩ	
	40°C (104°F)	Approx. 1.148 KΩ	
	60°C (140°F)	Approx. 0.586 KΩ	
	80°C (176°F)	Approx. 0.322 KΩ	
Cooling fan thermo-switch operating temperature	OFF→ON	Approx. 85°C (185°F)	
	ON→OFF	Approx. 78°C (172°F)	
Engine coolant type	Use an antifreeze/coolant compatible with aluminum radiator, mixed with distilled water only, at the ratio of 50 : 50		
Engine coolant capacity	Reserve tank side	300 ml	
	Radiator side	370 ml	
	Engine side	480 ml	

⊙ ELECTRICAL

Unit : mm (in)

ITEM	STANDARD		NOTE
Ignition timing	<i>MSB</i> <small>BSB</small>	BTDC 10° / 2,000rpm ~ 30° / 5,000rpm	
	<i>MSB</i> <small>BSF</small>	BTDC 10° / 2,000rpm ~ 28° / 4,000rpm	
Spark plug	Type	CR8E	
	Gap	0.7 ~ 0.8 (0.028 ~ 0.032)	
	Hot type	CR7E	
	Standard type	CR8E	
	Cold type	CR9E	
Spark performance	Over 8mm (0.32)		
Ignition coil primary peak voltage	150 V and more		
Ignition coil resistance	Primary	3.5 ~ 5.5 Ω	
	Secondary	20 ~ 31 KΩ	
Magneto coil resistance	Pick-up coil	80 ~ 120 Ω	G-L
	Charging coil	0.7 ~ 1.3 Ω	Y-Y
Magneto no-load voltage	Over 70 V / 5,000 rpm		
Battery standard charging voltage	13.5 ~ 15.0 V / 5,000 rpm		
Battery	Type	YTX9-BS	
	Capacity	12V 8Ah	
	Standard electrolyte S.G.	1.320 at 20°C (68°F)	
Fuse size	Main	30A	
	Head lamp	15A	

⊙ WATTAGE

Unit : W

ITEM	SPECIFICATION	
Head lamp	HI	55 W
	LO	55 W
	Position	5 W × 2
License plate lamp	5 W	
Brake / Tail lamp	21 / 5 W	
Turn signal lamp	LED type	
Speedometer lamp	1.7 W × 5	
Turn signal indicator lamp (Right & left)	LED type	
High beam indicator lamp	LED type	
FI ckeck lamp	LED type	

※ LED : Light Emitting Diode



CAUTION

Do not use except the specified bulb (Wattage).

⊙ **SUSPENSION**

Unit : mm (in)

ITEM	STANDARD	LIMIT
Front fork stroke	85 (3.35)	—
Front fork spring free length	280.4 (11.04)	—
Front fork oil type	TELLUS #22	—
Front fork oil level	116 mm (4.6 in) from end of outer tube (when maximum compressed without spring)	—
Front fork oil capacity (each leg)	120 cc	—
Rear wheel travel	66 (2.6)	—
Rear shock absorber spring length	214.1 (8.43)	—

⊙ **BRAKE + WHEEL**

Unit : mm (in)

ITEM		STANDARD	LIMIT
Brake disk thickness	Front	4.0 (0.16)	3.0 (0.12)
	Rear	4.3 (0.17)	3.0 (0.12)
Brake disk runout	Front · Rear	—	0.08 (0.003)
Master cylinder bore	Front	12.700 ~ 12.743 (0.5000 ~ 0.5017)	—
	Rear	14.000 ~ 14.043 (0.5512 ~ 0.5529)	—
Master cylinder piston diam.	Front	12.657 ~ 12.684 (0.4983 ~ 0.4994)	—
	Rear	13.957 ~ 13.984 (0.5495 ~ 0.5506)	—
Brake caliper cylinder bore	Front · Rear	25.400 ~ 25.476 (1.0000 ~ 1.0030)	—
Brake caliper piston diam.	Front · Rear	25.320 ~ 25.370 (0.9969 ~ 0.9988)	—
Brake fluid type	Front	DOT4	—
	Rear	DOT4	—
Wheel runout	Axial	—	0.1 (0.004)
	Radial	—	0.5 (0.020)
Wheel axle runout	Front	—	0.2 (0.008)
	Rear	—	0.03 (0.001)
Tire size	Front	120/70 - 13M/C 53S	—
	Rear	140/60 - 14M/C 64S	—
Wheel rim size	Front	13×3.5	—
	Rear	14×4.0	—

⊙ TIRE PRESSURE

COLD INFLATION TIRE PRESSURE	NORMAL RIDING					
	SOLO RIDING			DUAL RIDING		
	kPa	kgf/cm ²	psi	kPa	kgf/cm ²	psi
FRONT	172	1.75	25.0	172	1.75	25.0
REAR	197	2.00	29.0	246	2.50	36.0

⊙ FUEL + OIL

ITEM	SPECIFICATION		NOTE
Fuel type	Gasoline used should be graded 91 octane or higher. An unleaded gasoline is recommended.		
Fuel tank capacity	8 ℓ		
Engine oil & Transmission oil type	API Over SL (SAE 10W/40)		
Engine oil capacity	Change	800 mℓ	
	Oil Filter change	900 mℓ	
	Overhaul	1,000 mℓ	
Transmission oil capacity	Change	400 mℓ	
	Overhaul	410 mℓ	

WIRE AND CABLE ROUTING

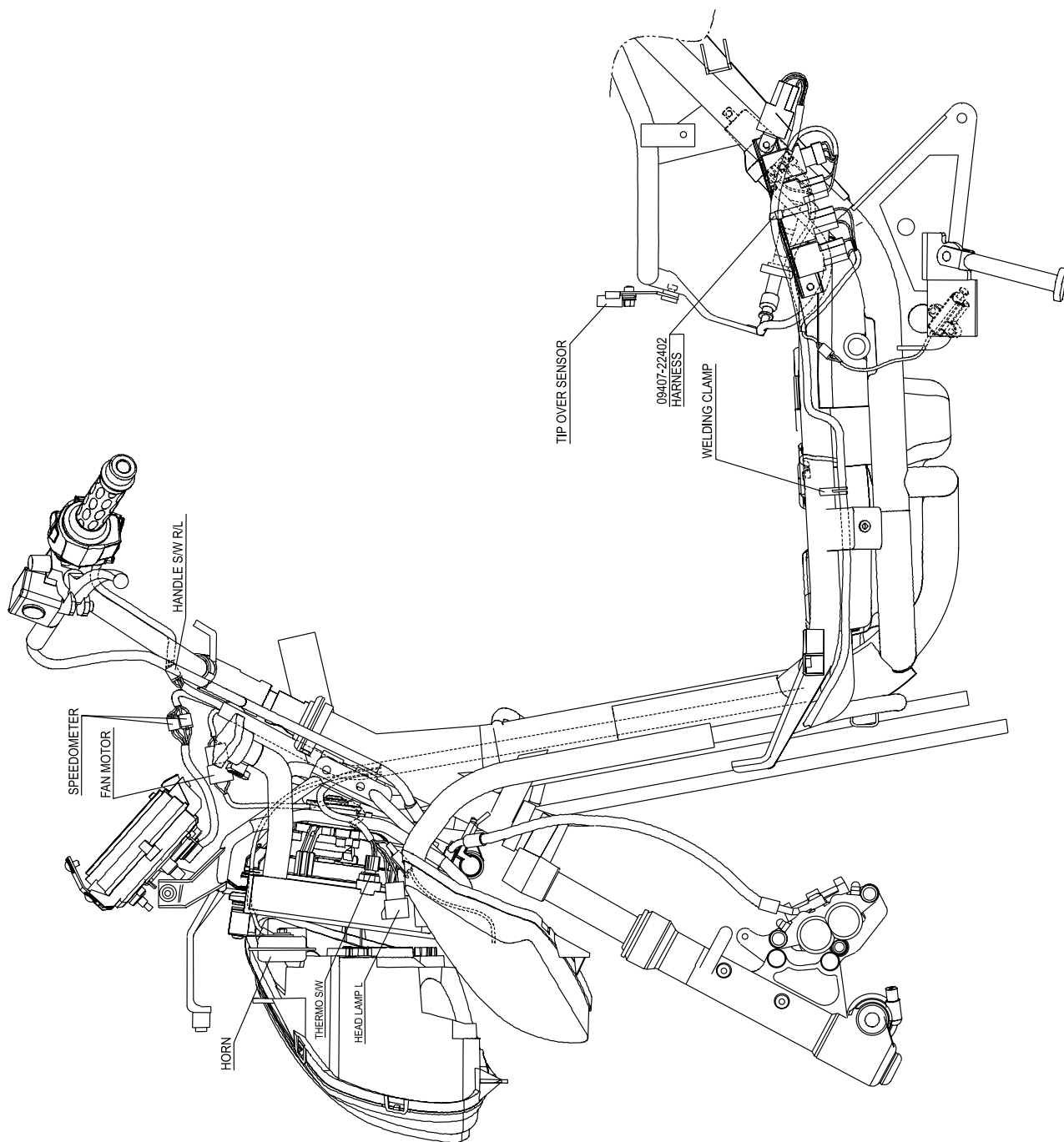

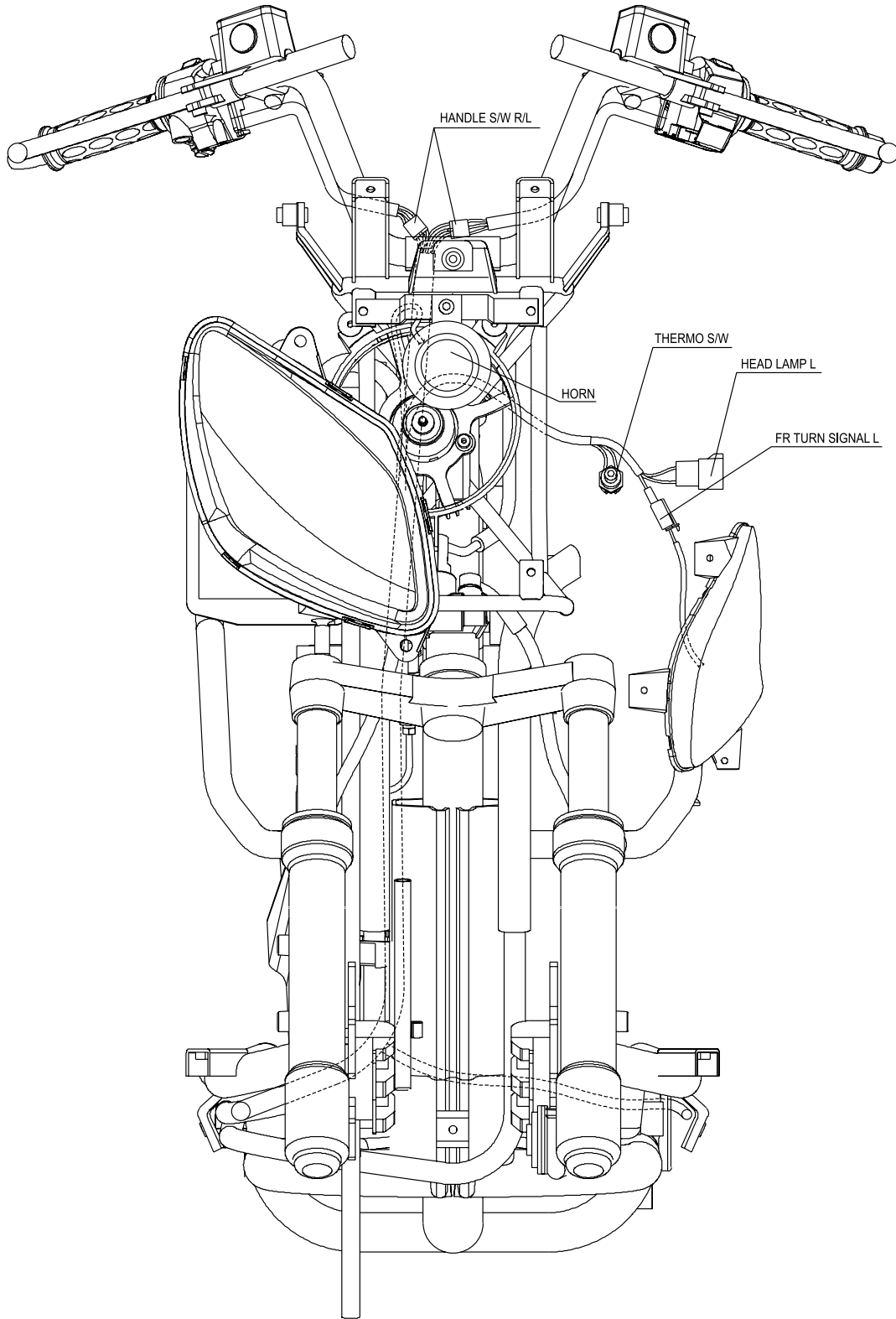

9-33 SERVICING INFORMATION

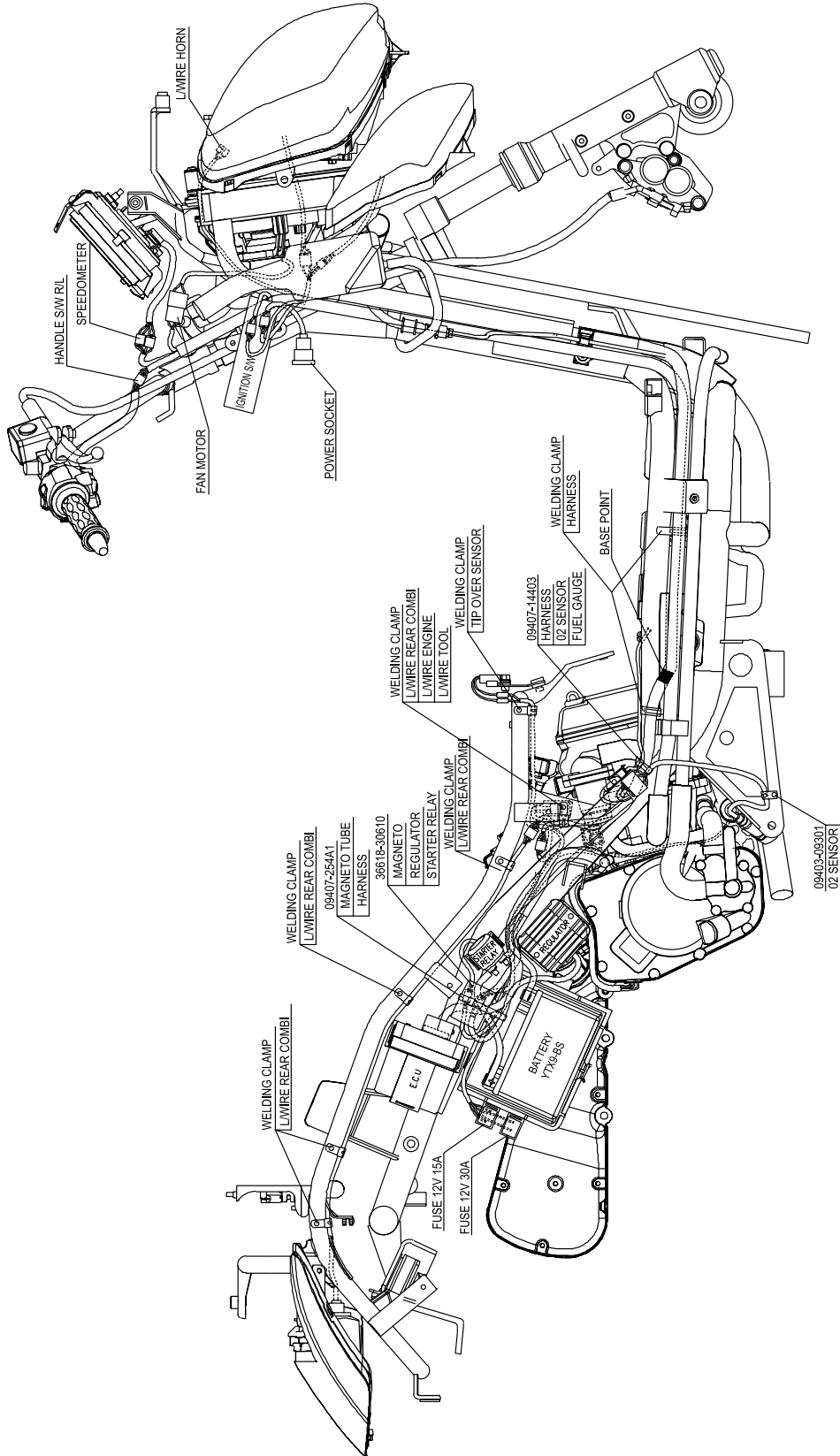

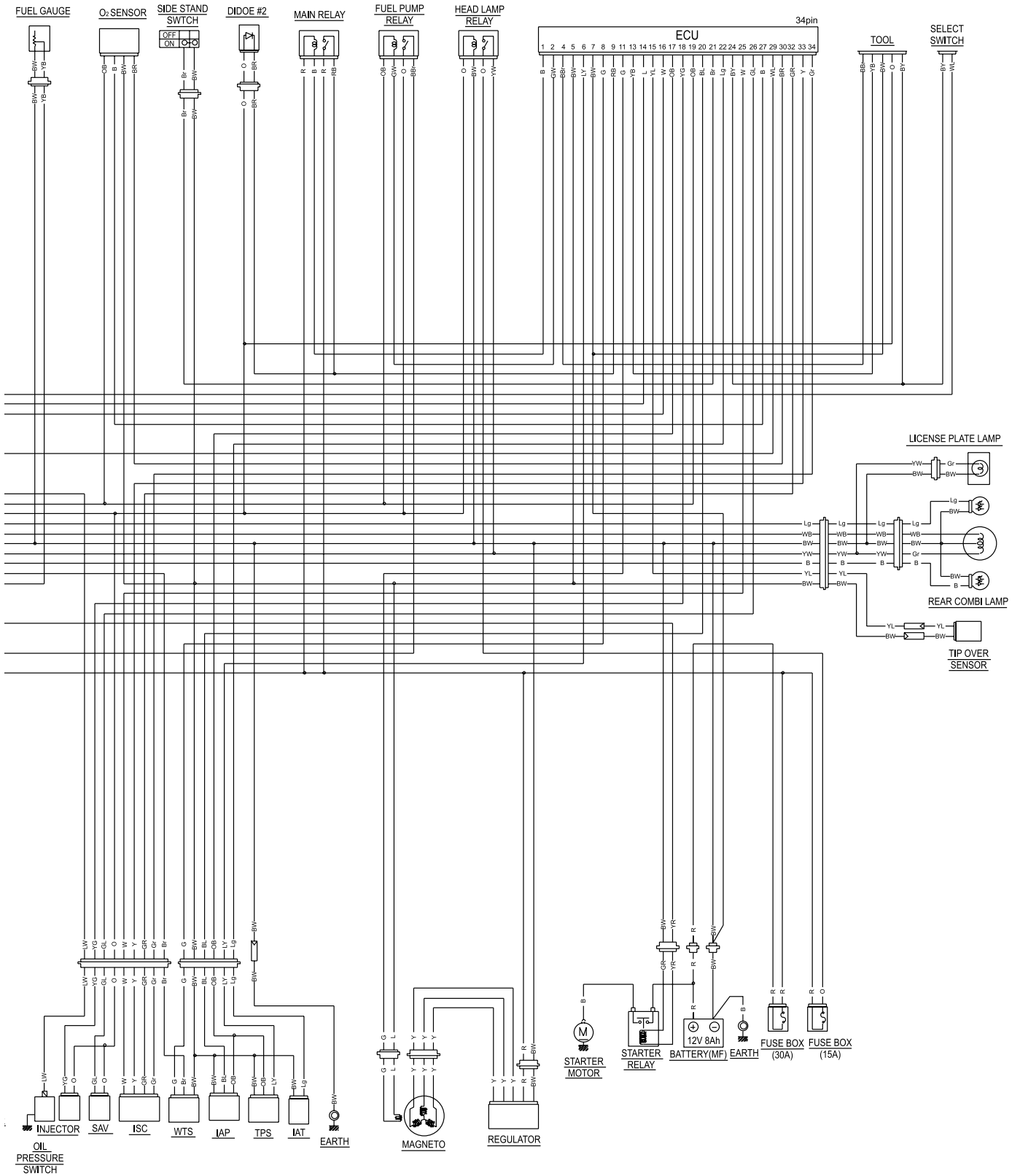

TAPPET SHIM SELECTION CHART (IN.)

MEASURING TAPPET CLEARANCE (mm)	SHIM No.	120	125	130	135	140	145	150	155	160	165	170	175	180	185	190	195	200	205	210	215	220
		Specified clearance - Adjustment unnecessary																				
0.00 ~ 0.04				1.20	1.25	1.30	1.35	1.40	1.45	1.50	1.55	1.60	1.65	1.70	1.75	1.80	1.85	1.90	1.95	2.00	2.05	2.10
0.05 ~ 0.09		1.20	1.25	1.30	1.35	1.40	1.45	1.50	1.55	1.60	1.65	1.70	1.75	1.80	1.85	1.90	1.95	2.00	2.05	2.10	2.15	2.20
0.10 ~ 0.20																						
0.21 ~ 0.25		1.30	1.35	1.40	1.45	1.50	1.55	1.60	1.65	1.70	1.75	1.80	1.85	1.90	1.95	2.00	2.05	2.10	2.15	2.20	2.20	2.20
0.26 ~ 0.30		1.35	1.40	1.45	1.50	1.55	1.60	1.65	1.70	1.75	1.80	1.85	1.90	1.95	2.00	2.05	2.10	2.15	2.20	2.20	2.20	2.20
0.31 ~ 0.35		1.40	1.45	1.50	1.55	1.60	1.65	1.70	1.75	1.80	1.85	1.90	1.95	2.00	2.05	2.10	2.15	2.20	2.20	2.20	2.20	2.20
0.36 ~ 0.40		1.45	1.50	1.55	1.60	1.65	1.70	1.75	1.80	1.85	1.90	1.95	2.00	2.05	2.10	2.15	2.20	2.20	2.20	2.20	2.20	2.20
0.41 ~ 0.45		1.50	1.55	1.60	1.65	1.70	1.75	1.80	1.85	1.90	1.95	2.00	2.05	2.10	2.15	2.20	2.20	2.20	2.20	2.20	2.20	2.20
0.46 ~ 0.50		1.55	1.60	1.65	1.70	1.75	1.80	1.85	1.90	1.95	2.00	2.05	2.10	2.15	2.20	2.20	2.20	2.20	2.20	2.20	2.20	2.20
0.51 ~ 0.55		1.60	1.65	1.70	1.75	1.80	1.85	1.90	1.95	2.00	2.05	2.10	2.15	2.20	2.20	2.20	2.20	2.20	2.20	2.20	2.20	2.20
0.56 ~ 0.60		1.65	1.70	1.75	1.80	1.85	1.90	1.95	2.00	2.05	2.10	2.15	2.20	2.20	2.20	2.20	2.20	2.20	2.20	2.20	2.20	2.20
0.61 ~ 0.65		1.70	1.75	1.80	1.85	1.90	1.95	2.00	2.05	2.10	2.15	2.20	2.20	2.20	2.20	2.20	2.20	2.20	2.20	2.20	2.20	2.20
0.66 ~ 0.70		1.75	1.80	1.85	1.90	1.95	2.00	2.05	2.10	2.15	2.20	2.20	2.20	2.20	2.20	2.20	2.20	2.20	2.20	2.20	2.20	2.20
0.71 ~ 0.75		1.80	1.85	1.90	1.95	2.00	2.05	2.10	2.15	2.20	2.20	2.20	2.20	2.20	2.20	2.20	2.20	2.20	2.20	2.20	2.20	2.20
0.76 ~ 0.80		1.85	1.90	1.95	2.00	2.05	2.10	2.15	2.20	2.20	2.20	2.20	2.20	2.20	2.20	2.20	2.20	2.20	2.20	2.20	2.20	2.20
0.81 ~ 0.85		1.90	1.95	2.00	2.05	2.10	2.15	2.20	2.20	2.20	2.20	2.20	2.20	2.20	2.20	2.20	2.20	2.20	2.20	2.20	2.20	2.20
0.86 ~ 0.90		1.95	2.00	2.05	2.10	2.15	2.20	2.20	2.20	2.20	2.20	2.20	2.20	2.20	2.20	2.20	2.20	2.20	2.20	2.20	2.20	2.20
0.91 ~ 0.95		2.00	2.05	2.10	2.15	2.20	2.20	2.20	2.20	2.20	2.20	2.20	2.20	2.20	2.20	2.20	2.20	2.20	2.20	2.20	2.20	2.20
0.96 ~ 1.00		2.05	2.10	2.15	2.20	2.20	2.20	2.20	2.20	2.20	2.20	2.20	2.20	2.20	2.20	2.20	2.20	2.20	2.20	2.20	2.20	2.20
1.01 ~ 1.05		2.10	2.15	2.20	2.20	2.20	2.20	2.20	2.20	2.20	2.20	2.20	2.20	2.20	2.20	2.20	2.20	2.20	2.20	2.20	2.20	2.20
1.06 ~ 1.10		2.15	2.20	2.20	2.20	2.20	2.20	2.20	2.20	2.20	2.20	2.20	2.20	2.20	2.20	2.20	2.20	2.20	2.20	2.20	2.20	2.20
1.11 ~ 1.15		2.20	2.20	2.20	2.20	2.20	2.20	2.20	2.20	2.20	2.20	2.20	2.20	2.20	2.20	2.20	2.20	2.20	2.20	2.20	2.20	2.20

HOW TO USE THE CHART

1. Measure the tappet clearance. (When cold)
2. Measure the shim thickness at present.
3. Look for meeting space in that horizontal line for thickness and vertical line for clearance.

(EXAMPLE)

When the tappet clearance is 0.23mm and the shim thickness at present is 1.70mm, the shim thickness should be used 1.80mm.



TAPPET SHIM SELECTION CHART (EX.)

MEASURING TAPPET CLEARANCE (mm)	SHIM No.		Specified clearance - Adjustment unnecessary																			
	SHIM THICKNESS AT PRESENT (mm)		120	125	130	135	140	145	150	155	160	165	170	175	180	185	190	195	200	205	210	215
0.05 ~ 0.09	1.20	1.25	1.30	1.35	1.40	1.45	1.50	1.55	1.60	1.65	1.70	1.75	1.80	1.85	1.90	1.95	2.00	2.05	2.10	2.15	2.20	2.20
0.10 ~ 0.14	1.20	1.25	1.30	1.35	1.40	1.45	1.50	1.55	1.60	1.65	1.70	1.75	1.80	1.85	1.90	1.95	2.00	2.05	2.10	2.15	2.20	2.20
0.15 ~ 0.19	1.20	1.25	1.30	1.35	1.40	1.45	1.50	1.55	1.60	1.65	1.70	1.75	1.80	1.85	1.90	1.95	2.00	2.05	2.10	2.15	2.20	2.15
0.20 ~ 0.30																						
0.31 ~ 0.35	1.30	1.35	1.40	1.45	1.50	1.55	1.60	1.65	1.70	1.75	1.80	1.85	1.90	1.95	2.00	2.05	2.10	2.15	2.20	2.20	2.20	2.20
0.36 ~ 0.40	1.35	1.40	1.45	1.50	1.55	1.60	1.65	1.70	1.75	1.80	1.85	1.90	1.95	2.00	2.05	2.10	2.15	2.20	2.20	2.20	2.20	2.20
0.41 ~ 0.45	1.40	1.45	1.50	1.55	1.60	1.65	1.70	1.75	1.80	1.85	1.90	1.95	2.00	2.05	2.10	2.15	2.20	2.20	2.20	2.20	2.20	2.20
0.46 ~ 0.50	1.45	1.50	1.55	1.60	1.65	1.70	1.75	1.80	1.85	1.90	1.95	2.00	2.05	2.10	2.15	2.20	2.20	2.20	2.20	2.20	2.20	2.20
0.51 ~ 0.55	1.50	1.55	1.60	1.65	1.70	1.75	1.80	1.85	1.90	1.95	2.00	2.05	2.10	2.15	2.20	2.20	2.20	2.20	2.20	2.20	2.20	2.20
0.56 ~ 0.60	1.55	1.60	1.65	1.70	1.75	1.80	1.85	1.90	1.95	2.00	2.05	2.10	2.15	2.20	2.20	2.20	2.20	2.20	2.20	2.20	2.20	2.20
0.61 ~ 0.65	1.60	1.65	1.70	1.75	1.80	1.85	1.90	1.95	2.00	2.05	2.10	2.15	2.20	2.20	2.20	2.20	2.20	2.20	2.20	2.20	2.20	2.20
0.66 ~ 0.70	1.65	1.70	1.75	1.80	1.85	1.90	1.95	2.00	2.05	2.10	2.15	2.20	2.20	2.20	2.20	2.20	2.20	2.20	2.20	2.20	2.20	2.20
0.71 ~ 0.75	1.70	1.75	1.80	1.85	1.90	1.95	2.00	2.05	2.10	2.15	2.20	2.20	2.20	2.20	2.20	2.20	2.20	2.20	2.20	2.20	2.20	2.20
0.76 ~ 0.80	1.75	1.80	1.85	1.90	1.95	2.00	2.05	2.10	2.15	2.20	2.20	2.20	2.20	2.20	2.20	2.20	2.20	2.20	2.20	2.20	2.20	2.20
0.81 ~ 0.85	1.80	1.85	1.90	1.95	2.00	2.05	2.10	2.15	2.20	2.20	2.20	2.20	2.20	2.20	2.20	2.20	2.20	2.20	2.20	2.20	2.20	2.20
0.86 ~ 0.90	1.85	1.90	1.95	2.00	2.05	2.10	2.15	2.20	2.20	2.20	2.20	2.20	2.20	2.20	2.20	2.20	2.20	2.20	2.20	2.20	2.20	2.20
0.91 ~ 0.95	1.90	1.95	2.00	2.05	2.10	2.15	2.20	2.20	2.20	2.20	2.20	2.20	2.20	2.20	2.20	2.20	2.20	2.20	2.20	2.20	2.20	2.20
0.96 ~ 1.00	1.95	2.00	2.05	2.10	2.15	2.20	2.20	2.20	2.20	2.20	2.20	2.20	2.20	2.20	2.20	2.20	2.20	2.20	2.20	2.20	2.20	2.20
1.01 ~ 1.05	2.00	2.05	2.10	2.15	2.20	2.20	2.20	2.20	2.20	2.20	2.20	2.20	2.20	2.20	2.20	2.20	2.20	2.20	2.20	2.20	2.20	2.20
1.06 ~ 1.10	2.05	2.10	2.15	2.20	2.20	2.20	2.20	2.20	2.20	2.20	2.20	2.20	2.20	2.20	2.20	2.20	2.20	2.20	2.20	2.20	2.20	2.20
1.11 ~ 1.15	2.10	2.15	2.20	2.20	2.20	2.20	2.20	2.20	2.20	2.20	2.20	2.20	2.20	2.20	2.20	2.20	2.20	2.20	2.20	2.20	2.20	2.20
1.16 ~ 1.20	2.15	2.20	2.20	2.20	2.20	2.20	2.20	2.20	2.20	2.20	2.20	2.20	2.20	2.20	2.20	2.20	2.20	2.20	2.20	2.20	2.20	2.20
1.21 ~ 1.25	2.20	2.20	2.20	2.20	2.20	2.20	2.20	2.20	2.20	2.20	2.20	2.20	2.20	2.20	2.20	2.20	2.20	2.20	2.20	2.20	2.20	2.20

HOW TO USE THE CHART

1. Measure the tappet clearance. (When cold)
2. Measure the shim thickness at present.
3. Look for meeting space in that horizontal line for thickness and vertical line for clearance.

(EXAMPLE)

When the tappet clearance is 0.33mm and the shim thickness at present is 1.70mm, the shim thickness should be used 1.80mm.



Prepared by



1st Ed. DEC. 2007.

Manual No. 99000HP8810

Printed in Korea